

# Matrix

## Column Array series

# USER'S MANUAL

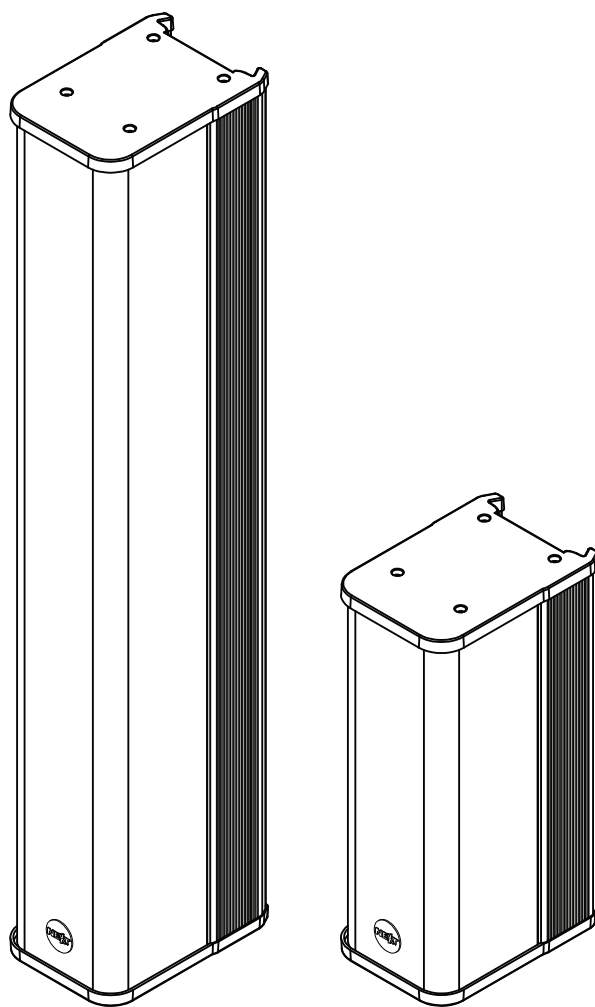

**NEXT**  
proaudio

Thank you for purchasing NEXT-proaudio Speakers and their associated products.  
Please carefully follow the instructions in this manual to ensure long, trouble-free use of your equipment.

V201805



INTRODUCTION	-1-
UNPACKING	-1-
MATRIX SERIES OVERVIEW	-1-
SAFETY FIRST	-2-
CONNECTIONS/FEATURES	-3-
BACK PANEL SWITCHES	-4-
100V TAP SELECTOR	-4-
APPLICATION EXAMPLES	-5-
WALL BRACKETS	-6-
SPEAKER POLE BRACKETS	-8-
EXTENSION LINK PLATE	-10-
100V KIT	-11-
TROUBLESHOOTING	-12-
INTERNAL CONNECTIONS DIAGRAM	-12-
CROSSOVER REPLACEMENT	-13-
TECHNICAL SPECIFICATIONS	-14-
WARRANTY POLICY	-15-
CONTACTS	-16-

## INTRODUCTION

Thank you for purchasing a NEXT-proaudio Matrix Series speaker. This manual will provide you with useful and important information about your column array element. Please devote some time reading this manual, and keep it at hand for future reference. NEXT-proaudio is concerned with your safety and well-being, so please follow all instructions and heed all warnings. Also, a better understanding of some specific features of the speaker will help you to operate it to its full potential. With a continuous evolution of techniques and standards, NEXT-proaudio, reserves the right to change the specifications of its products without early warning. For the most current data, please visit our website: [www.next-proaudio.com](http://www.next-proaudio.com)

## UNPACKING

NEXT-proaudio Matrix series are built in Europe (Portugal) by NEXT-proaudio, according to the highest standards and thoroughly inspected before leaving the factory. When unpacking your element, carefully examine it for any signs of possible transit damage and inform your dealer immediately if any such damage has occurred.

It is suggested that you retain the original packaging so that the cabinet can be repacked in the future if necessary. Please note that NEXT-proaudio and its authorized distributors cannot accept any responsibility for damage to any returned product through the use of non-approved packaging.

## MATRIX SERIES OVERVIEW

The MATRIX passive column arrays are composed by 3" neodymium transducers housed in a stylish and yet sturdy aluminum/wood chassis for an excellent architectural integration.

These speaker arrays have been developed in order to offer the highest intelligibility at high SPL and wider frequency response while providing constant beam-width over a user selectable vertical coverage. This accurate beam control extends up to 10kHz, well beyond the benchmark of 4kHz of traditional single-driver loudspeakers.

A user selectable Music / Vocal mode switch is incorporated to allow quick and easy system optimization. Music mode provides a flat, balanced frequency response, while Vocal mode adds a mid-range presence for enhanced speech intelligibility.

NEXT MATRIX column arrays are able to focus the acoustical energy where it is needed, the listening area, leading to significant improvements to speech intelligibility and musical clarity even in critical acoustic environments.

For even greater versatility, the vertical dispersion pattern can be switched for Wide or Narrow coverage.

Small conventional column loudspeakers arrays provide no significant vertical directivity control at lower frequencies due to their physical size. To better control the lower frequencies, the Tuned Dipolar Technology was developed to provide more consistent low frequency pattern control than other similar size systems. The TDT helps reducing the stimulation of resonant room modes at low frequencies.

For high-impedance (100V) operation, an optional multi tap transformer is available.



## **SAFETY FIRST**

- Do not use your M speaker near to any sources of water, like swimming pools, lakes, water streams, exposed to rain, high humidity environments or any other source of water or moisture.
- Use only a soft dry cloth to clean your M speaker.
- Never place your M speaker in a way that prevents air flow near to the side bass reflex ports. A minimum clearance distance of 10cm should be kept between the ports and any near surface.
- Never use your M speaker too close to any heat source, such as radiators, or any other device that produces heat.
- Place cables in a way that they do not present a trip hazard.
- Do not place any objects on top of the speaker, they can fall accidentally and cause injuries.
- Do not attempt to move the enclosures while connected.
- Do not attempt to service the M speakers beyond what is described in this manual. All other service or repair of this product should be carried only by qualified personnel.
- To prevent electric shock, do not use any extension cord, receptacle or other outlets where the blades of the connectors cannot be fully inserted.
- Do not operate the unit for an extended period of time with the sound distorting.

## **RIGGING AND SUSPENSION SAFETY CONSIDERATIONS**

- Before rigging or suspending Matrix series systems, inspect all components and all hardware for any signs of damaged or missing parts. If you find any damaged, corroded or deformed parts, do not use them, replace them immediately.
- Use only the recommended NEXT-proaudio wall brackets. Doing otherwise may cause the element to fall off, resulting in personal injury.
- Install the unit only in a location that can structurally support the weight of the unit and the mounting bracket. Doing otherwise may cause the element to fall off, resulting in personal injury and/or property damage.
- Use nuts and bolts that are appropriate for the wall's materials and structure. Doing otherwise may cause the element to fall off, resulting in personal injury and/or property damage.

## CONNECTIONS/FEATURES

The M3 and M8 speakers are equipped with a 4-positions Phoenix connector. The first two pins correspond to IN+ / IN-, the last two pins are Link+ / Link-, internally linked to the input sockets.

NEXT-proaudio supplies two female connectors (2-positions), one for input and one for link purposes. The screw connector provides a faster and easier way to wire the system allowing the speaker to perfectly fit the wall shape while keeps invisible.

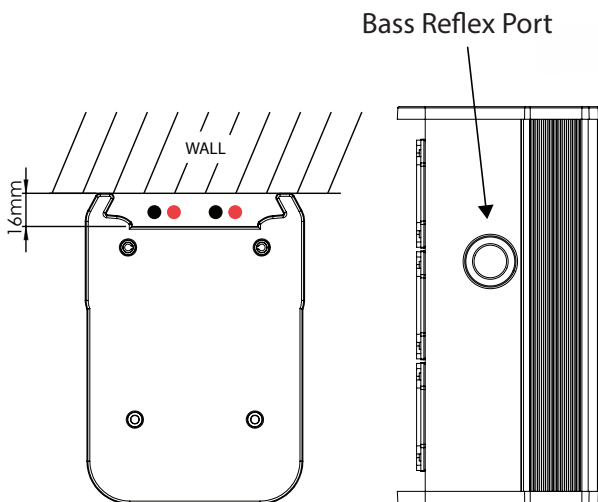
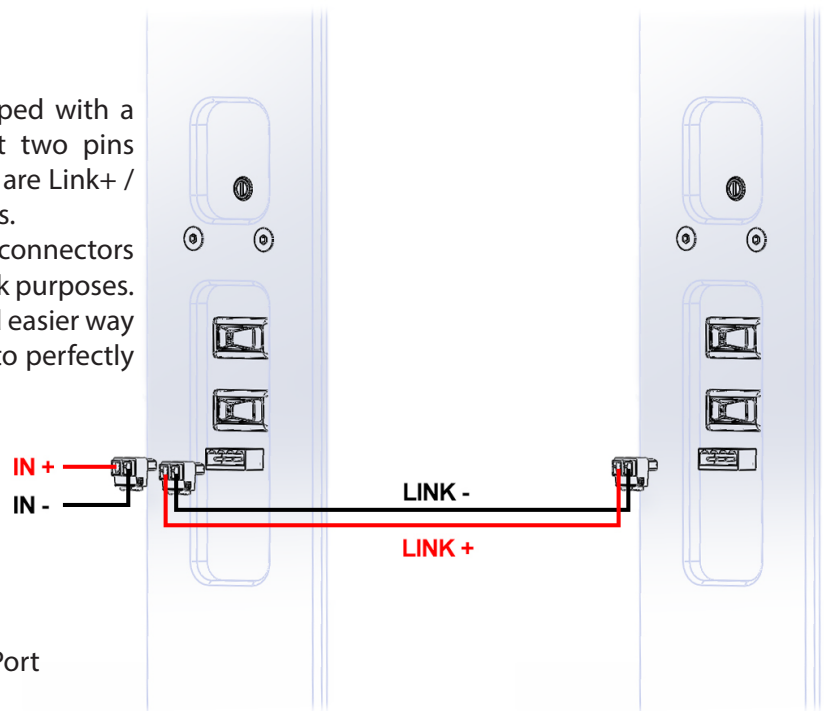

For an architectural integrated installation, a 16mm cavity in the back of the speaker provides ample space for hidden speaker wiring, even when the speaker is mounted flat against the wall.

Avoid to install it with a side wall once the bass reflex ports are placed on the speaker's sides. The ports promote an even better speaker's cooling. A minimum clearance distance of 10cm is advisable.

Both M3 and M8 can be supplied with a SpeakON NL4 connector for portable solutions. The connection pins are 1+/1-, the 2+/2- are not connected. Further details will be explained on "Accessories" chapter.

The SpeakON NL4 option can not coexist with the 100V speaker version.

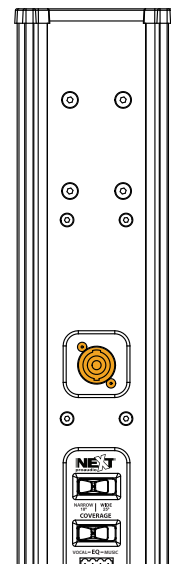

## BACK PANEL SWITCHES

The M8 speaker is equipped with 2 distinct sliding switches. The first switch is intended to passively adjust the vertical coverage among the two possible options (10° or 25°). The bottom one allows the user to select between Vocal or Music equalization. On the Music position the system will perform a flat frequency response. When on the Vocal selection, the speaker will increase the mid-high frequency range to enhance speech intelligibility.

The M3 speaker only has a single switch capable of doing both functions, EQ and vertical coverage control. When the switch is on the left most position, the speaker will have a narrow vertical coverage (15°) doted with a mid-high frequency boost. On the other side, when sliding the switch to the right, the listener can expect a wider vertical coverage (40°) with a uniform music spectral response.



## 100V TAP SELECTOR

Both M3 and M8 can be supplied on a 100V version. The M3 has a 40W line transformer installed while the M8 relies on a 80W audio transformer.

When supplied on the 100V version, the speakers will have an extra rotary selector placed on the back panel near the connections panel. On this new section the user can find four different switch positions according to the pretended power. To change the switch position a flat screwdriver is recommended.

On the M3, the selectable power is 5W, 10W, 20W or 40W.

On the M8 the available power is 10W, 20W, 40W or 80W.



## APPLICATION EXAMPLES

As the vertical coverage is very restricted, avoiding undesirable reflections, the aiming of the speakers is a very important step on the installation of new units. Along with the optimal speaker positioning, the selected coverage and EQ is highly significant for a good uniformity and sound quality.

### *NARROW MODE*

When the audience is totally seated or totally standing, the narrow mode can cover the venue with the best control and with a maximized distance range. The acoustic center of the speaker must be aligned with the listener's ears.

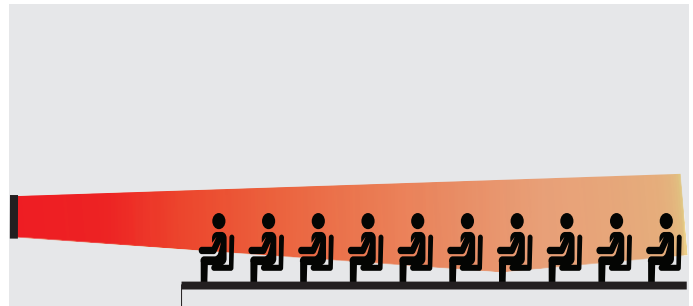

### *WIDE MODE*

When the audience is both seated and standing, the wide mode can be an excellent solution once it can spread the energy reaching the whole audience. The acoustic center of the speaker must be aligned with the mean height of the listener's ears. The Wide mode can also be used on tilted audiences.

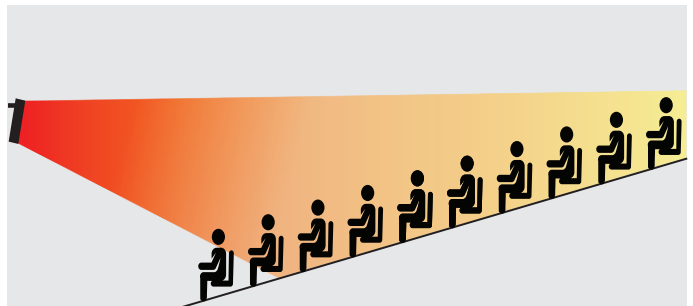

### *COMBINED COVERAGES*

On larger venues, where the audience extends over a long distance, the best call would be combine two M8 units. On that case the user must couple them using the Extension Link Plate (available as an accessory). Both units must be set to Narrow coverage mode in order to minimize interference between both speakers.

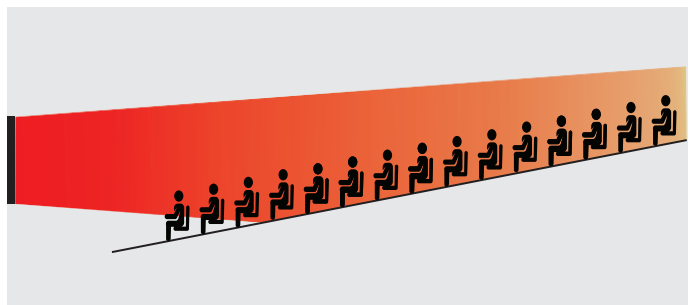

## WALL BRACKETS

### STILL WALL BRACKET (FLAT AGAINST THE WALL)

The still wall bracket (Fig.1) is the most simple wall bracket on this series. It is intended to be used on M3 and M8 on the most discreet install applications. With this accessory the speaker will be perfectly leaning against the wall, there are no visible cables or brackets.

The still wall bracket is constituted by two symmetrical pieces that perfectly match each other.

The install process is as simple as hanging a picture on the wall. Just screw one of the parts to the wall, the other part to the speaker and slide it down until both pieces perfectly fit each other (Fig. 2).

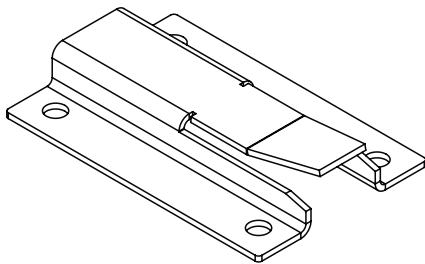

Fig. 1

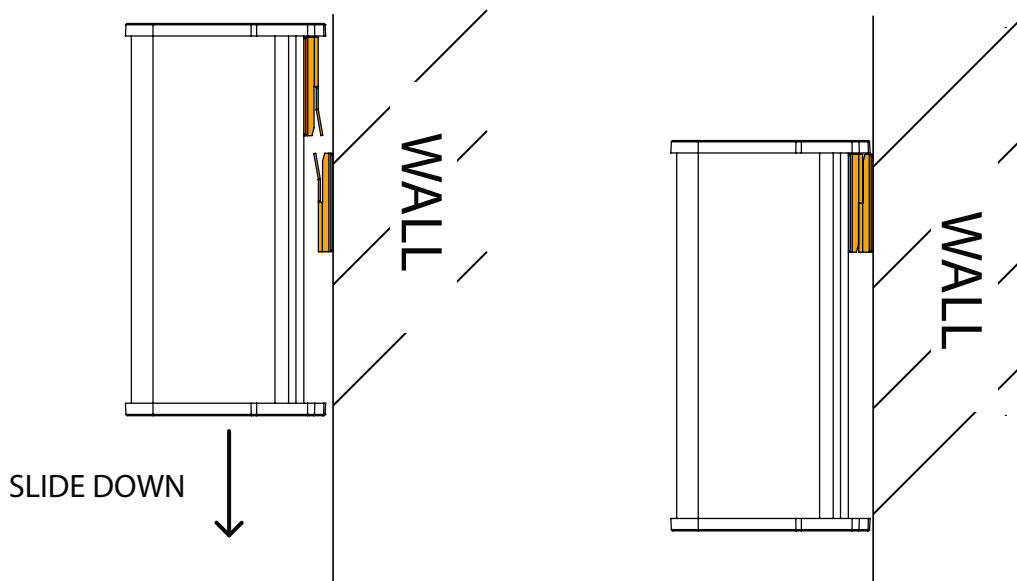
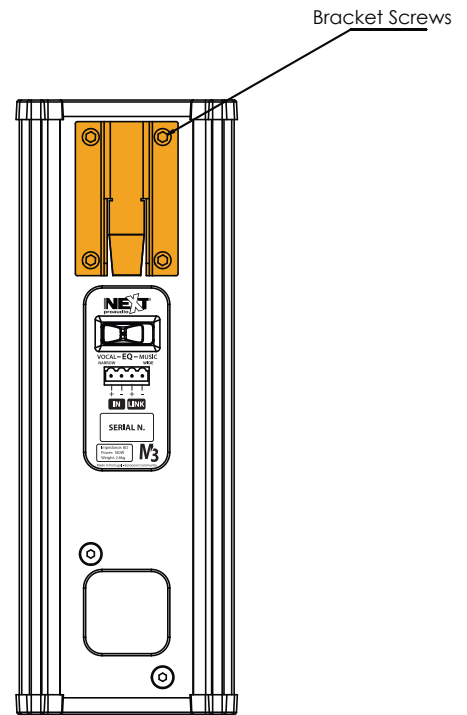

Fig. 2

Note: For visual purposes, the aluminum profile was hidden. On a realistic situation the wall bracket will be completely invisible.

## WALL BRACKETS

### ADJUSTABLE WALL BRACKET

Both M3 and M8 are able to use the adjustable wall bracket (Fig. 3). This bracket was designed to provide some degrees of freedom to the speakers allowing pan and tilt movements. The bracket can be either attached on the superior section of the speaker as well as on the bottom part enabling the user to have more flexibility choosing the inclination angles.

When hooked up on the top of the M8 (Fig. 4), the tilting angle range is from **0° to 10°**. If the adjustable bracket is attached on the inferior section of the M8 (Fig. 5), the tilting angle will vary between **0° and 30°**.

On the M3 model, the only option is to attach the adjustable wall bracket on the superior part of the cabinet (Fig. 6) providing a movement between **0° and 28°**.

On both cabinets, M3 and M8, the maximum pan movement will have a span of **146° (73° for each side)**.

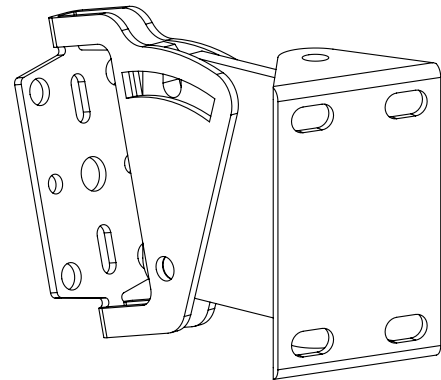

Fig. 3

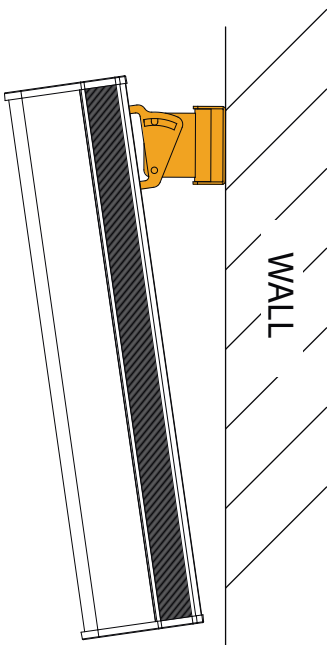

Fig. 4

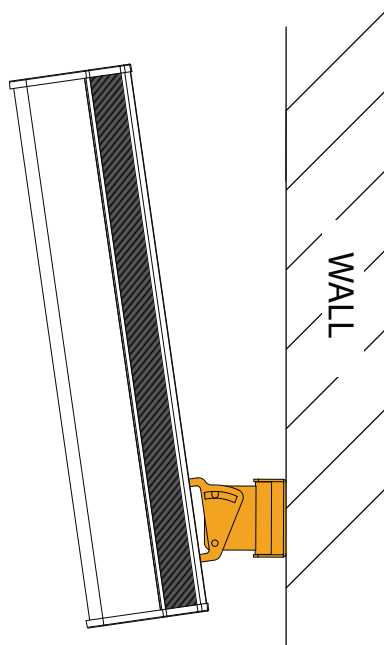

Fig. 5

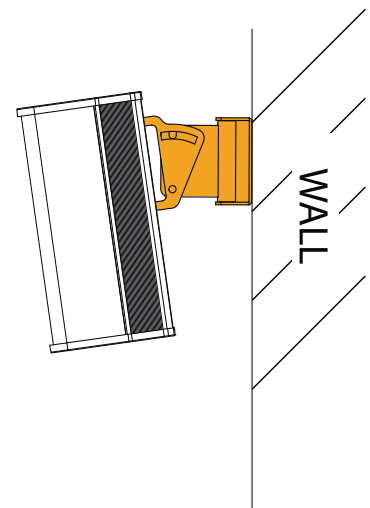

Fig. 6

## SPEAKER POLE BRACKETS

### SPEAKER POLE BRACKET ON M8 CABINET

In order to fulfill the requirements of the most demanding venue applications, this series made available a speaker pole bracket (Fig. 7) that easily fits the speaker on a pole or a speaker standing. This accessory is ready for the standard pole diameter of 35mm.

The equipment can be permanently installed on the speaker, using the provided bolts, washers and nuts (Fig. 9), or it can be used in an easy-on-easy-off application (Fig. 10) when combined with the still wall bracket (Fig. 8).

When using the speaker pole bracket, is also possible to use the SpeakON NL4 connector located on the panel above the main panel (Fig. 9). The SpeakON NL4 connector is not a standard accessory and can't be applied by the user.

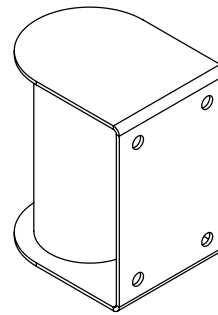

Fig. 7

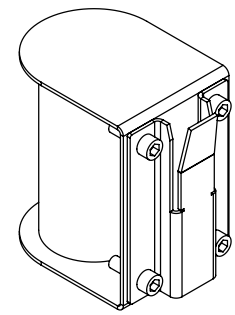

Fig. 8

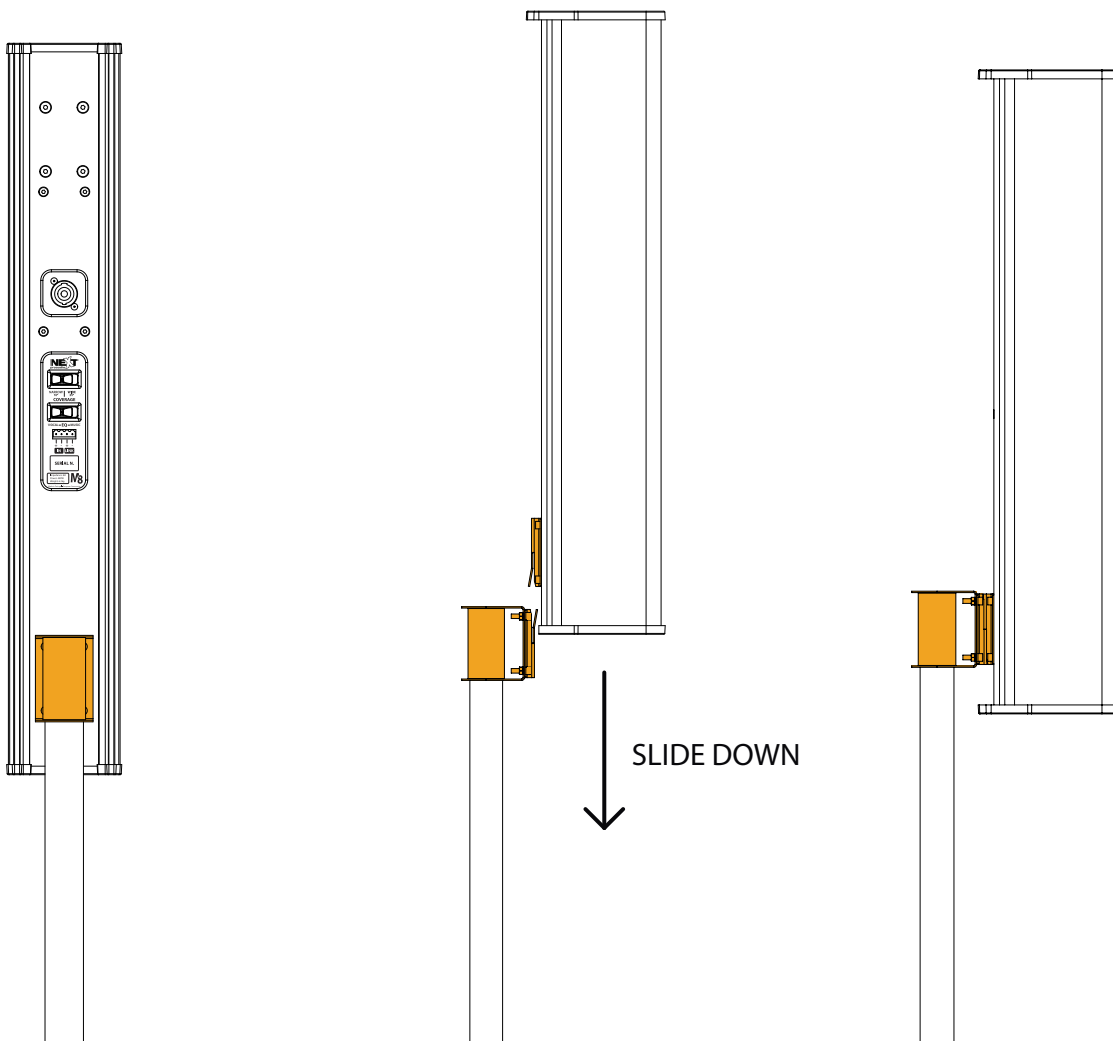

Fig. 9

Fig. 10

## SPEAKER POLE BRACKETS

### SPEAKER POLE BRACKET ON M3 CABINET

The same speaker pole bracket that fits M8, also fits the M3 cabinet.

On the M3 speaker is also possible to use the speaker pole bracket either with Phoenix connector (Fig. 11) or with SpeakON NL4 connector (Fig. 12).

When using the Phoenix connector, the speaker pole bracket can be installed both on the speaker's top or bottom positions (Fig. 11).

When using the NL4 connection, the accessory can only be attached on the speaker's top position. Please follow the instructions below:

- 1 - Rotate the speaker upside down
- 2 - Apply the speaker pole bracket
- 3 - Rotate the logo badge on the front grill (the logo will be on the speaker's top). Please also rotate the grill upside down if you need the logo on the speaker's bottom position.

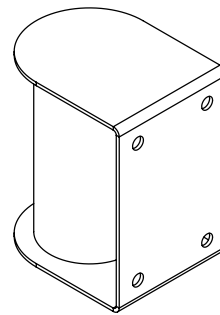

Fig. 7

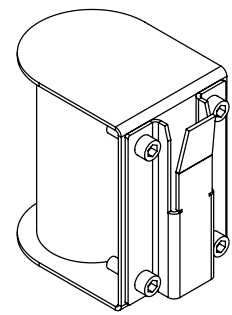

Fig. 8

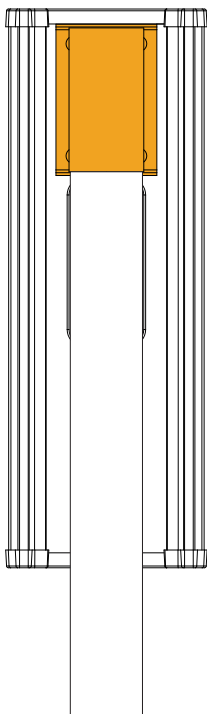

Fig. 11

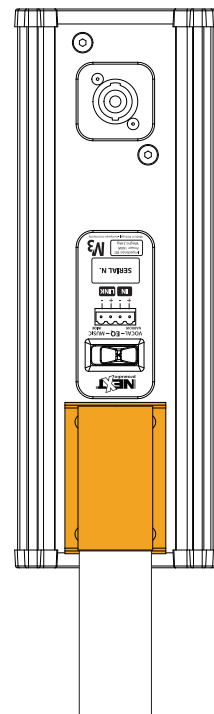
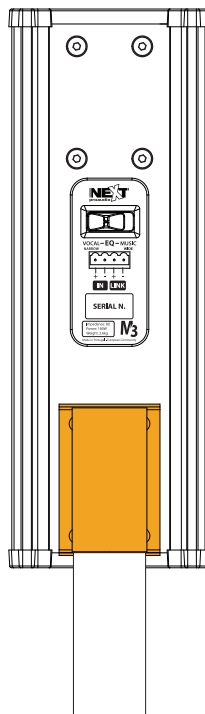

Fig. 12



## EXTENSION LINK PLATE

For the largest venues, where the high SPL and coverage uniformity are needed, the best option is to couple two M8 cabinets, one on top of the other, forming a 16 speakers array. To accomplish that task, an Extension Link Plate (Fig. 13) is provided as a speaker accessory.

To apply the Extension Link Plate, please follow the instructions below:

- 1 - Lay both speakers on a flat surface
- 2 - Remove the 4 screws from each cabinet (4 screws on the top of each speaker)
- 3 - Install the Extension Link Plate using the bolts and washers supplied on the kit (Fig. 14). Both speaker tops must be joined together with the top speaker placed in a upside down position (Fig. 15).
- 4 - Install the Still Wall bracket on the top (The Speaker Pole Bracket can not be used on this configuration. The Adjustable Wall Bracket can be used with some movement restrictions)
- 5 - Rotate the logo placed on the front grill for a better look (Fig. 16)

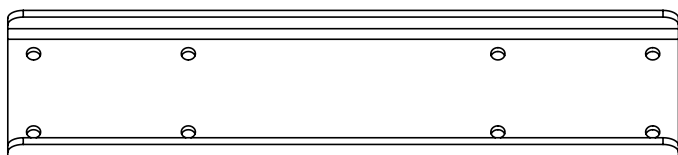

Fig. 13

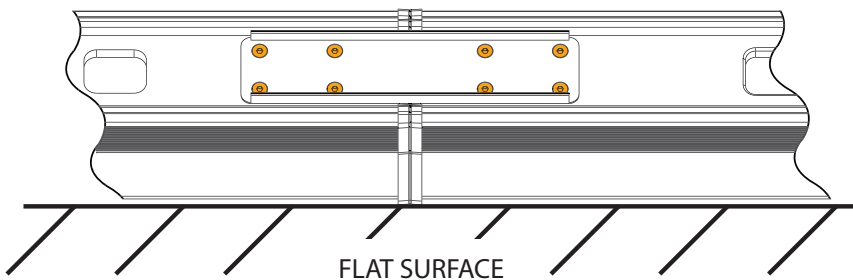

Fig. 14

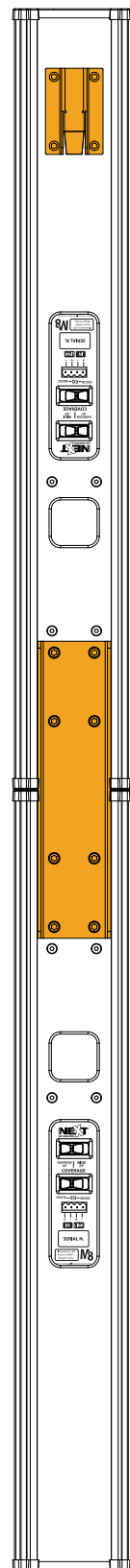

Fig. 15

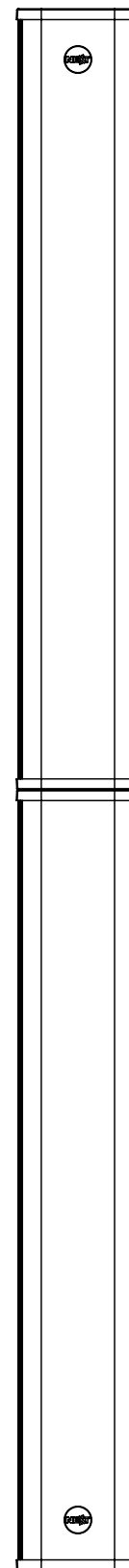
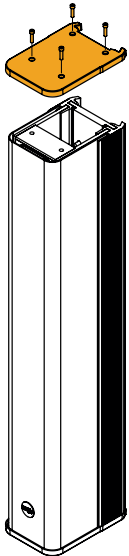

Fig. 16

## 100V KIT

The Matrix series speakers can be either supplied with 100V kit or it can be easily installed by the user as an external accessory. To install procedure, please refer to the guide below. Obs: After install, the input connector will operate the same way as for low impedance.



Step 1:  
Unscrew the top cover screws and remove it

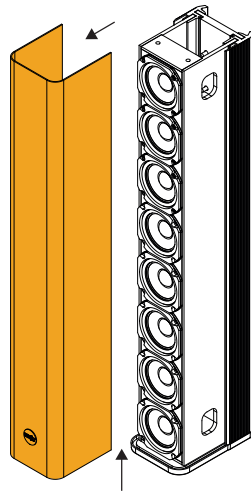

Step 2:  
Remove the grill by slightly pulling it up and out

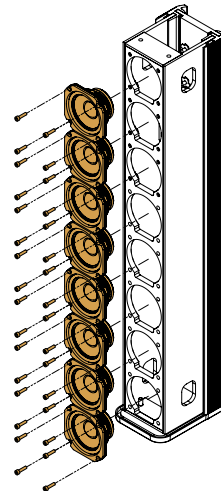

Step 3:  
Remove all the loudspeakers. Is not needed to disconnect them.

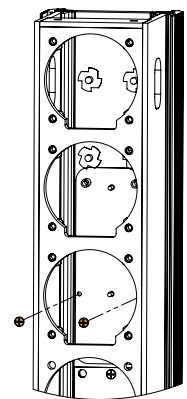

Step 4:  
Remove the two Philips screws attached on the blank plate

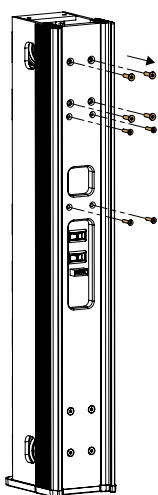

Step 5:  
Unscrew the 8 back screws. The blank plate will be loose, hold it on place

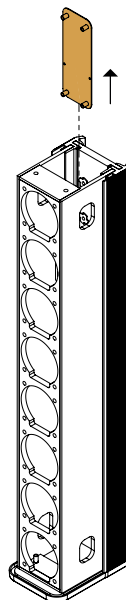

Step 6:  
Remove the blank plate from the top aperture. Disconnect the IN+/IN- from the PCB

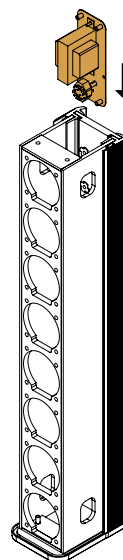

Step 7:  
Install the 100V transformer kit. Connect the IN+/- PCB cables to the transformer. Connect the transformer cables to the 8ohm+/- faston connectors on the PCB

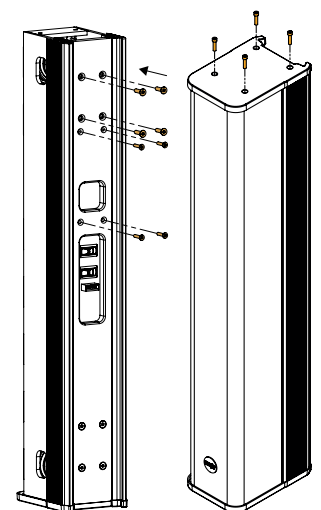

Step 8:  
Re-screw all the screws and re-assemble the loudspeaker, grill and top cover (see step 6 from "Crossover Replacement" chapter)

## TROUBLESHOOTING

Simple troubleshooting does not require sophisticated measurement equipment and can be easily undertaken by users. The technique should be to segment the system in order to identify the faulty system component. A simple sweep with a sine wave generator can be very helpful though it **MUST** be made at a fairly low level to prevent damage to the speakers. A sine wave sweep can help find:

- Vibrations due to loose screws.
- Air-leak noises: check that no screws are missing, particularly where the accessories attach to the cabinet.
- Vibrations due to a front grille badly positioned on the quick release fixings.
- Foreign object that has fallen into the cabinet after repair or through the ports.
- Internal connection wires or absorbing material touching the loudspeaker diaphragm

## INTERNAL CONNECTIONS DIAGRAM

The diagrams below are the internal connections for M3 and M8 speakers respectively.

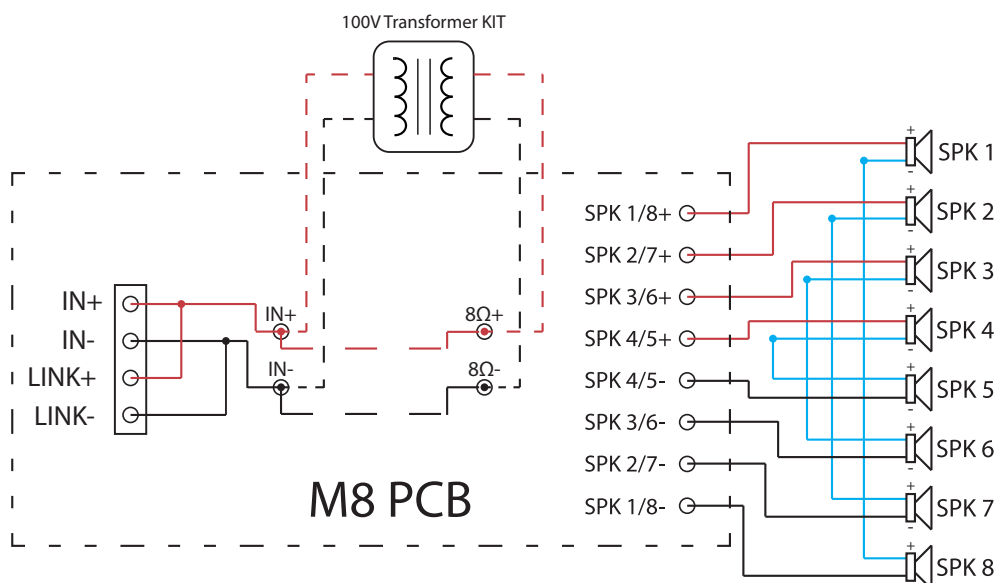
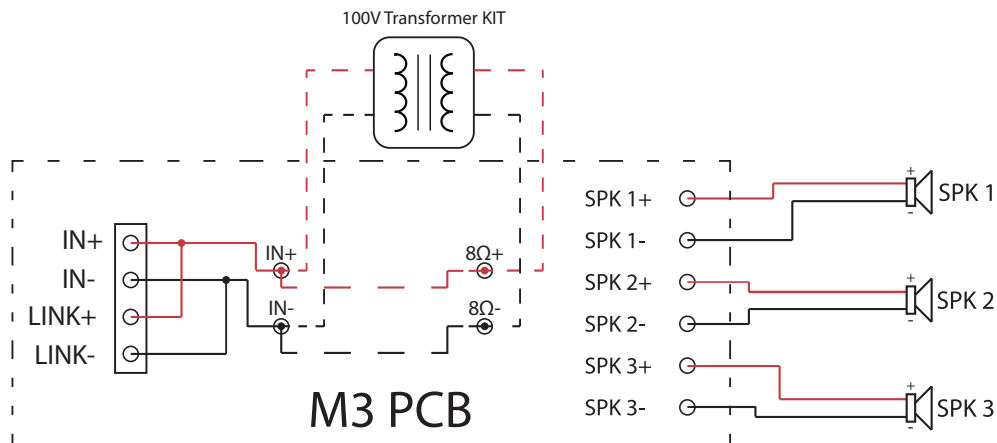

## CROSSOVER REPLACEMENT

In the unlikely event of crossover failure, it can be easily replaced following the guide below.

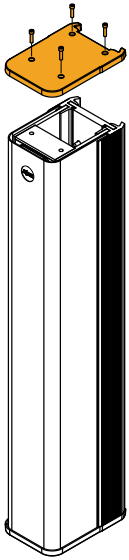

**Step 1:**  
Rotate the speaker upside down, unscrew the bottom cover screws and remove the cover

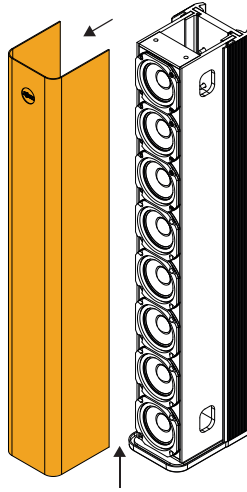

**Step 2:**  
Remove the grill by slightly pulling it up and out

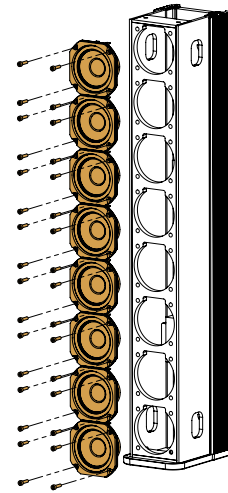

**Step 3:**  
Remove all the loudspeakers and disconnect only the black and brown cables

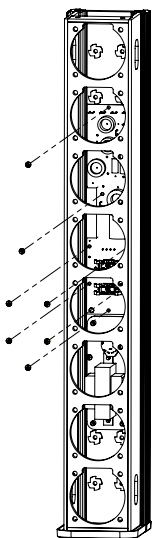

**Step 4:**  
Remove the 7 Philips screws that hold the PCB in place

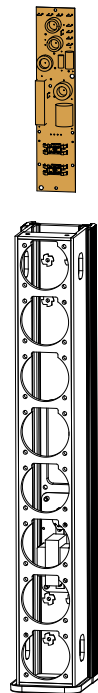

**Step 5:**  
Remove the PCB pulling it up. Install the new PCB and re-connect all the cables

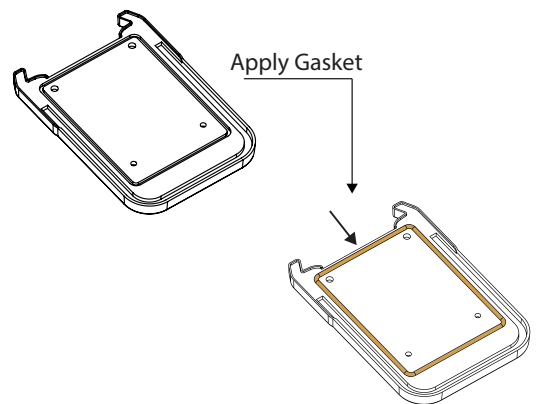

**Step 6:**  
Re-assemble the loudspeakers, grill and bottom cover (verify if the gasket is perfectly fitting the cover, if not, please take it off and re-install it)

**TECHNICAL SPECIFICATIONS**

<b>NEXT M3/M8 TECHNICAL SPECIFICATIONS</b>		
	<b>M3</b>	<b>M8</b>
<b>Speaker Type</b>	<b>Tuned Dipolar, Variable Beam Straight Line Array</b>	
<b>Frequency Response (-10dB)</b>	<b>140Hz – 20kHz</b>	<b>135Hz – 20kHz</b>
<b>Equalizer Optimization Mode</b>	<b>Vocal or Music (User Selectable)</b>	
<b>Sensitivity (1W@1m) Vocal/Music</b>	<b>96dB/93dB</b>	<b>100dB/97dB</b>
<b>Calculated Max. SPL Vocal (Continuous/Peak)</b>	<b>118.6dB/121.6dB</b>	<b>126.1dB/139.1dB</b>
<b>Calculated Max. SPL Music (Continuous/Peak)</b>	<b>115.6dB/118.6dB</b>	<b>123.1dB/126.1dB</b>
<b>Horizontal Coverage Angle (-6dB)</b>	<b>90°</b>	
<b>Vertical Coverage Angle (-6dB) Narrow/Wide</b>	<b>15°/40°</b>	<b>10°/25°</b>
<b>Components</b>	<b>FR - 3 x 3" / 0.75" Voice Coil Custom Speaker</b>	<b>FR - 8 x 3" / 0.75" Voice Coil Custom Speaker</b>
<b>Rated Power</b>	<b>180W</b>	<b>480W</b>
<b>Nominal Impedance</b>	<b>8Ω</b>	
<b>Recommended Amplifier</b>	<b>MA900</b>	<b>MA1700</b>
<b>Recommended Subwoofer</b>	<b>K12s, K12sA, HFA115s</b>	<b>HFA115s, HFA115sHP, HFA118sHP</b>
<b>100V Transformer Taps (Optional)</b>	<b>40W, 20W, 10W, 5W</b>	<b>80W, 40W, 20W, 10W</b>
<b>Connectors [optional]</b>	<b>4 Pins Screw Connector (IN/OUT) [SpeakON NL4]</b>	
<b>Construction</b>	<b>Aluminum / Wood / Steel / 3D Fabric</b>	
<b>Finish</b>	<b>Semi-matte paint</b>	
<b>Grille</b>	<b>Black-powder coated perforated grille</b>	
<b>Dimensions WxHxD [mm] (in)</b>	<b>[108 x 299 x 153] (4.25 x 11.77 x 6.02)</b>	<b>[108 x 685 x 153] (4.25 x 26.97 x 6.02)</b>
<b>Net Weight</b>	<b>2.6kg (5.7lb)</b>	<b>6.2kg (13.7lb)</b>

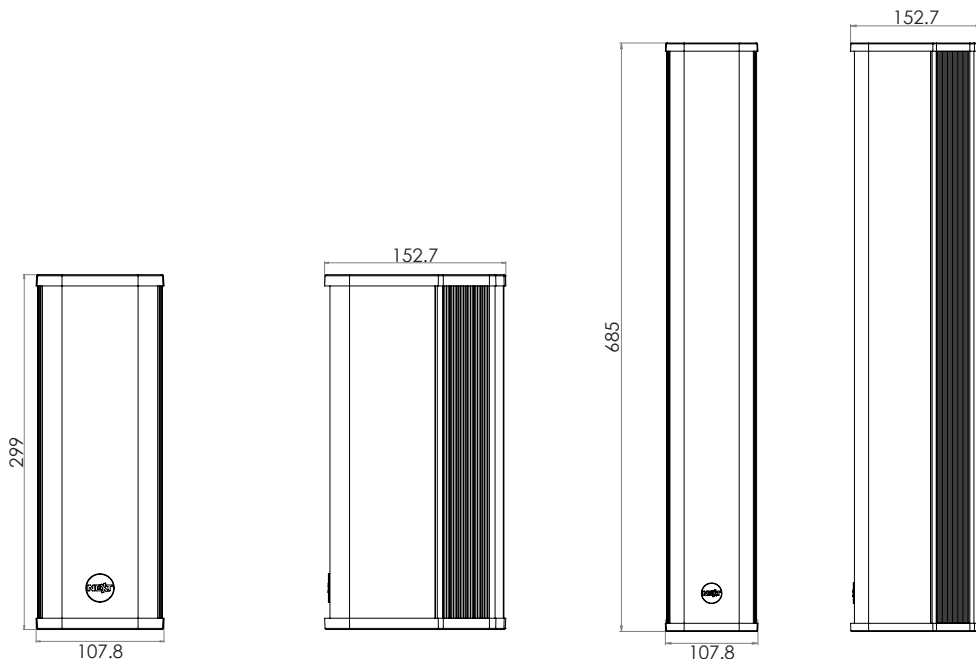

## WARRANTY POLICY

NEXT-proaudio's products are warranted, by NEXT-proaudio, against manufacturing defects in materials or craftsmanship over a period of 5 years for the passive loudspeakers, and 2 years for all other products counting from the date of original purchase. The original receipt of purchase is mandatory for warranty validation purposes, and the product must have been bought from a NEXT-proaudio authorized dealer.

The warranty can be transferred to a subsequent owner during the warranty period; however, this cannot extend the warranty period beyond the original warranty period of five years from the original date of purchase stated on the NEXT-proaudio's invoice.

During the warranty period NEXT-proaudio will, at its own discretion, either repair or replace a product which prove to be defective provided that the product is returned in its original packaging, shipping prepaid, to an authorized NEXT-proaudio service agent or distributor.

NEXT-proaudio cannot be held responsible for defects caused by unauthorized modifications, improper use, negligence, exposure to inclement weather conditions, act of God or accident, or any use of this product that is not in accordance with the instructions provided by this manual and/or NEXT-proaudio. NEXT-proaudio is not liable for consequential damages.

This warranty is exclusive and no other warranty is expressed or implied. This warranty does not affect your statutory rights.



## CONTACTS

In case of any doubts or any information just:

Write us:

NEXT-PROAUDIO  
Rua da Venda Nova, 295  
4435-469 Rio Tinto  
Portugal

Contact us:

Tel. +351 22 489 00 75  
Fax. +351 22 480 50 97

Send an e-mail:

[info@next-proaudio.com](mailto:info@next-proaudio.com)

Search our website:

[www.next-proaudio.com](http://www.next-proaudio.com)

Follow us on:



Facebook: [facebook.com/nextproaudio](https://facebook.com/nextproaudio)



Instagram: [instagram.com/nextproaudio](https://instagram.com/nextproaudio)



LinkedIn: [linkedin.com/company/next-proaudio](https://linkedin.com/company/next-proaudio)



Twitter: [twitter.com/next\\_proaudio](https://twitter.com/next_proaudio)



Youtube: [youtube.com/user/NEXTmanufacturer](https://youtube.com/user/NEXTmanufacturer)