



Bekafun



Turntable Bible

05.2020



Bekafun

Heilig Hartstraat 23
B-8870 Izegem
info@bekafun.be
T 051 31 28 03
F 051 31 82 18
BE 0457 542 763

Open

maandag tot vrijdag van 9u- 18u
zaterdag van 10u - 17u
zondag gesloten

Bekafun & EV Sound is doorlopend open,
ook over de middag

Gesloten

1-2 januari
2de Pasen
1 mei
Hemelvaart
Pinkstermaandag
21 juli
15 augustus
1 november
11 november
25 december
(geen jaarlijks verlof)

Bank

België
KBC: BE 03 4650 1316 8184
(BIC: KREDBEBB)
ING: BE 62 3850 1016 5461
(BIC: BBRUBEBB)

Nederland
ING: NL 83 INGB 0659 8072 70
(BIC: INGBNL2A)

U kunt in de winkel betalen met:
cash / visa / mastercard
bancontact / payconic
op rekening na goedkeuring
(enkel voor klanten met btw nr.)

Online kunt u betalen met:
prepayment / visa / mastercard
bancontact / payconic
op rekening na goedkeuring
(enkel voor klanten met btw nr.)

Volg ons op



BEKAFUN ontstond in 1990 als een beperkte verhuurfirma. Sinds 1998 specialiseren we ons in de verkoop van pro audio, licht en AV aan zowel particuliere DJ's, verhuurfirma's, verenigingen en bedrijven.

PRIJS

Wij proberen goed aan te kopen en zijn niet bang buiten België aan te kopen. Wij bieden een laagste prijs garantie, vindt u hetzelfde product ergens anders goedkoper, dan passen wij onze prijs aan!

Als professionele klant krijgt u van ons een PRO-account met gepersonaliseerde prijzen en exclusieve promoties.

SERVICE

Ons sterke punt is onze **2550m² stock**. Wij zijn niet zomaar een webshop, opererend vanuit een garage, wij hebben het effectief staan.

Onze **eigen hersteldienst** met kennis van zaken staat steeds paraat voor onderhoud en reparaties van alle producten binnen onze sector.

Op het einde van de rit willen we U de beste prijs geven, op alles, service inbegrepen.

Bezoek onze websites

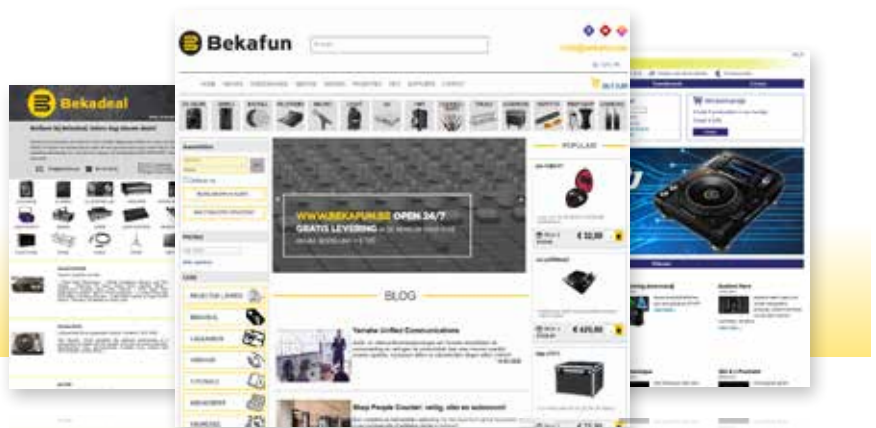

www.bekafun.com

www.evsound.be

www.bekadeal.be

www.flightpro.be

www.mobiltruss.be

www.turbosound.be

www.roadreadycases.be

Edito



VINYL - HOTTER THAN EVER

Met de komst van de CD en digitale muziek leek het glanzende zwarte goud "vinyl" ten dode opgeschreven en had het enkel nog een toekomst in selecte audiofiële kringen die zweren bij het analoge gebeuren.

Bij de opmars van streaming-diensten herontdekte het grote publiek de liefde voor muziek en zocht men alternatieven met meer authenticiteit. Dit resulteerde in een jaarlijkse stijging in de platenverkoop, het heropenen van persfabrieken van weleer en zelfs de heropstart van platenspelers in het Technics-assortiment.

Sinds 2018 heeft de vinyl-industrie opnieuw een groter marktaandeel dan de verkoop van CD's en is het een must voor bijna elke artiest om albums op LP uit te brengen.

Vinyl was zelden zo toegankelijk als nu, daarom stellen we u met trots onze selectie van producten aan u voor. Ben je een die-hard "vinyl-DJ", een audiofiële muziek-fanaticus of wil je in een nostalgische bui die LP's van op zolder nog eens beluisteren? Wij hebben voor elk wat wils, inclusief alle nodige accessoires voor aangename luister-momenten.

Het Bekafun team

Inhoudsopgave

4-9

TURNTABLES

10-12

CARTRIDGES

13

SLIPMATS

14

ISOLATION

15

CLEANING

16-18

TIMECODE

19-113

STYLI GUIDE FOR ALL BRANDS

114-175

TONAR ACCESSOIRES



tec-sl1200g

€ 3500,00

SL-1200G**Grand Class Coreless Direct Drive Motor Turntable**

- High-precision motor control technology
- Three-layered turntable platter
- High-level balance adjustment
- Four layered cabinet construction
- High Sensitive Tonearm
- Gold-plated Terminals
- Turntable Speeds: 33 1/3, 45, 78 r/min
- Audio Output: PHONO(RCA), EARTH TERMINAL

**Technics**

tec-sl1200gr

€ 1499,00

SL-1200GR**Grand Class Coreless Direct Drive Motor Turntable**

- High-precision motor control technology
- High Sensitive Tonearm
- Rigid body and high-damping insulators
- Gold-plated Terminals
- Turntable Speeds: 33 1/3, 45, 78 r/min
- Audio Output: PHONO(RCA), EARTH TERMINAL
- Also available in black (tec-sl1210gr)

**Technics**

tec-sl-1500ceg-k

€ 999,00

SL-1500C**Premium Coreless Direct Drive Motor Turntable**

- High-precision motor control technology
- Built-in Phono Equalizer
- Ortofon 2M Red cartridge included
- Auto lifter function
- Turntable Speeds: 33 1/3, 45rpm (with switch 78 rpm)
- Audio Output: LINE(RCA), PHONO(RCA), EARTH TERMINAL
- Also available in silver

**Technics**

tec-sl1210mk7

~~999,00~~ € 899,00**SL-1210 MK7****Direct drive DJ turntable**

- Drive Method: Direct Drive
- Turntable Speeds: 33 1/3, 45rpm (with switch 78 rpm)
- Starting Torque: 0.18N·m / 1.8kg·cm (1.56 lbs-in)
- Build-up Characteristics: 0.7 s. from standstill to 33 1/3 rpm
- Wow and Flutter: 0.025% W.R.M.S.
- Turntable Platter: Aluminum die-cast

**Technics**



rel-rp8000mk2 610,07 € 488,00

RP8000 MK2

Professional upper torque turntable system

The most advanced DJ turntable ever made, developed in close collaboration with renowned international turntable musicians
 Designed for Serato DJ Pro: Control 7 new RGB colour-coded performance modes
 Platter Play: In this mode, the performance pads can be used to control the speed of the platter to enable melodic and more musical live performances
 Extra large, highly responsive performance pad



rel-rp7000mk2 508,39 € 429,00

RP7000 MK2

Professional upper torque turntable system

- Built for the club
- Rigid chassis construction with an even heavier design with additional reinforcements out of metal, rubber and moulding compound for high vibration damping and isolation
- More powerful starting torque (adjustable from 2.8 - 4.5 kg/cm)
- Fine-tuned motor control for further optimization of wow and flutter and rotation
- Also available in silver & gold



rel-rp4000mk2 294,86 € 249,00

RP4000 MK2

Professional high torque turntable system

- Solid DJ turntable for advanced users
- Reverse play, pitch reset and extendible needle illumination
- Precise motor control with 3 speeds
- Statically balanced s-shaped tone arm with hydraulic lift and anti-skating mechanism.
- Includes high-quality Ortofon OM Black cartridge
- Black metallic top panel and sturdy housing construction



rel-rp2000mk2 254,20 € 242,00

RP2000 MK2

Quartz-driven DJ turntable with direct drive

- Turntable for prospective DJs
- Statically balanced s-shaped tone arm with hydraulic lift and anti-skating mechanism.
- Includes high-quality Ortofon OM Black cartridge
- Black metallic top panel and sturdy housing construction
- Also available with USB interface to digitalize vinyl records



rel-turn5

762,59 € 749,99

TURN5**Direct Drive HiFi Turntable System**

- Quartz-controlled, direct-drive turntable
- Powerful DC motor & low-resonance die-cast platter
- High-quality control elements & connections
- Static balanced S-tone arm
- Includes Ortofon 2M Red cartridge
- Heavy-duty metal construction housing



rel-turn3

488,05 € 479,99

TURN3**Premium analogue HiFi turntable with digital USB-audio interface**

- Smooth belt drive & low-noise DC motor
- Electronic Speed Control for 33, 45 & 78 RPM
- Precision Tone Arm & Anti-Skating System Wheel
- USB Recording Function & Built-in pre-amp
- Semi-Automatic for Auto Stop
- Aluminum Diecast Platter with Deadening Rubber Coating
- Includes Ortofon 2M Red cartridge
- Also available with S-tone arm



rel-turn2

305,03 € 299,99

TURN2**Analogue HiFi turntable**

- Smooth belt drive & low-noise DC motor
- Static balanced, straight tone arm
- Classy, matt slimline housing with high-quality terminal
- Pre-installed elliptical Ortofon cartridge
- Turntable Speeds: 2 speeds (33 1/3, 45)
- Also available in red & white

**TURN2**



pio-plx1000

729,00 € 635,00

PLX-1000

High-torque Direct Drive Professional Turntable

- High-torque direct drive (33 rpm in 0.3 seconds)
- Classic DJ turntable layout
- S-shaped tone arm
- Multiple tempo control options: ±8%, ±16% and ±50%
- Tempo reset button
- Solid build for excellent vibration damping
- Professional-grade gold-plated RCA jacks
- Rubber-lined tone arm to improve isolation and prevent feedback
- No Cartridge



Pioneer Dj



pio-plx500b

349,00 € 319,00

PLX-500B

High-torque Direct Drive Turntable

- Excellent sound design
- Easy digital recording with integrated USB interface
- Integrated cover art display in dust cover.
- Pick your colour
- Dustcover, slipmat, and headshell (cartidge and stylus) included
- Available in black and white



Pioneer Dj



pih-pl-990

199,00 € 185,00

PL-990

Full Automatic Stereo Turntable

- Full automatic operation: To provide easy hands-off operation
- Low-mass straight tone arm: Highly sensitive and resistant to resonance, track records better
- Precision DC servo motor: Pioneer Stable Hanging motor ends spindle wobble for smoother and more accurate platter rotation
- Universal-type cartridge connector
- Phono EQ included



Pioneer





mah-tt15s1/n1m

€ 1899,00

TT-15S1**Premium Range Belt-drive Turntable**

- Solid acrylic resin chassis
- 3 cm-thick heavy acrylic platter with a black felt cover
- Solid aluminium feet and state-of-the-art ceramic bearings
- High-grade audio interconnector
- The motor is dampened and isolated from the chassis to prevent vibration influence
- Clever clamp system ensures excellent disc contact with platter
- The magnetic anti-skating system is contact-free to eliminate unwanted stylus stresses

**marantz**

ddj-vl12

846,99 € 519,00

VL12 PRIME**Professional Direct Drive Turntable With True Quartz Lock**

- Highest-in-industry 5kgf/cm torque on 'High' setting
- Isolated motor design, for optimal signal-to-noise ratio
- S-shaped tone arm for accurate tracking
- Reinterpreted tone arm support with dual-function 'lock or rest'
- 2-speed operation 33 1/3rd and 45 RPM
- Adjustable pitch range: $\pm 8\%$, 16%, 50%
- Built-in RGB lighting illuminates platter's edge
- Brightness control

**DENON DJ**

ate-lp140xpbk

€ 399,00

AT-LP140XP BLACK**Professional Direct Drive Manual Turntable**

- Experience high-fidelity audio and professional DJ performance
- Direct-drive, high-torque motor
- Fully manual operation
- Adjustable dynamic anti-skate control
- Professional anti-resonance, mass-damped, die-cast aluminium platter
- Including AT-XP3 cartridge with AT-HS6 universal headshell
- Also available in silver

 **audio-technica**

syn-xtrm1wc

419,00 € 352,00

X-TRM 1**Professional High Torque Turntable**

- Very High Torque Direct Drive motor: 4.5kg.cm
- 3 speeds: 33, 45, 78 rpm with quartz lock
- 3 Pitch adjustment ranges: +/-10% +/-20% +/-50%
- Forward / reverse play
- 2 Start / stop buttons for maximum flexibility
- Phono & Line output
- Static balanced S-shaped metal tonearm with lockable anti-skating
- NO CARTRIDGE included

**SYNQ**
AUDIO RESEARCH

adp-tt2930

€ 329,00

TT-2930**High-torque Professional turntable system**

- Direct Drive
- 33, 45 & 78 RPM
- S-shaped tonearm with Anti-skating
- Phono & Line output
- Reverse function
- ABS housing with heavy anti-vibration base
- Includes Audio-Technica headshell, NO CARTRIDGE

**audiophony**
EQUIPMENTS

stt-t52b

228,69 € 169,00

T.52**Belt-Drive Straight-arm Turntable**

- Easy to Operate Belt-Drive Turntable with Professional Features
- Sturdy Design with Comfortable and Practical Layout
- Pitch Control slider with (+/- 10% Adjustment)
- Straight Tone Arm Improves Tracking for Scratching
- Includes Quality Stanton 300 Cartridge Pre-mounted on Headshell
- 2 Playback Speeds (33 or 45 RPM)
- 2 Start/Stop Switches for Mix or Battle Setup

**stanton**

CONCORDE MKII GENERATION

De Concorde MkII-cartridges zijn uniek afgestemd op de eisen van moderne turntable-DJ's



Prod Code	Stylus	Tracking	Output	Freq. bereik	Use	Prijs
ort-mix	Spherical	3.0 g	6 mV	20-20.000 Hz	All-round	83,88 € 79,00
ort-mixtwinset	Spherical	3.0 g	6 mV	20-20.000 Hz	All-round	159,26 € 143,00
ort-dj	Spherical	4.0 g	6 mV	20-20.000 Hz	Scratch & backcueing	102,72 € 99,00
ort-djtwinset	Spherical	4.0 g	6 mV	20-20.000 Hz	Scratch & backcueing	196,96 € 189,00
ort-scratchmkii	Spherical	4.0 g	10 mV	20-18.000 Hz	Maximum scratch	€ 112,15
ort-scratchtwinset	Spherical	4.0 g	10 mV	20-18.000 Hz	Maximum scratch	€ 211,00
ort-digital	Spherical	4.0 g	10 mV	20-18.000 Hz	Timecode vinyl	121,58 € 121,00
ort-digitaltwinset	Spherical	4.0 g	10 mV	20-18.000 Hz	Timecode vinyl	234,67 € 233,00
ort-club	Special Elliptical	3.0 g	8 mV	20-20.000 Hz	Detailed sound	140,42 € 139,00
ort-clubtwinset	Special Elliptical	3.0 g	8 mV	20-20.000 Hz	Detailed sound	272,26 € 269,00



Prod Code	Omschrijving	Prijs
ort-mixstylus	Stylus Concorde MKII Mix	28,27 € 24,90
ort-djstylus	Stylus Concorde MKII DJ	40,00 € 35,00
ort-scratchstylusmkii	Stylus Concorde MKII Scratch	€ 42,41
ort-digitalstylus	Stylus Concorde MKII Digital	€ 46,19
ort-clubstylus	Stylus Concorde MKII Club	55,60 € 55,00

OLD CONCORDE STYLI

Prod Code	Omschrijving	Prijs
ort-prostylus	Stylus Concorde Pro	35,98 € 28,00
ort-prostylus	Stylus Concorde Pro S	25,45 € 21,95
ort-djsstylus	Stylus Concorde DJ S	€ 36,74
ort-scratchstylus	Stylus Concorde Scratch	€ 46,19
ort-digitrackstylus	Stylus Concorde Digitrack	41,47 € 38,00
ort-nightclubbestylus	Stylus Concorde Nightclub E	53,72 € 49,00
ort-goldstylus	Stylus Concorde Gold	61,25 € 58,00
ort-arkivstylus	Stylus Concorde Arkiv	40,53 € 38,00

snk-10606001

47,48 € 45,90

S-15 HEADSHELL & PICK-UP SYSTEM
Headshell with Spherical Pick-up System & Stylus

- Frequency response:20-20000 Hz
- Recommended tracking force:30 mN
- Output voltage:5 mV
- Terminal resistance:47 kohms

snk-10606000

35,58 € 30,00

S-15 PICK-UP SYSTEM
Spherical Pick-up System & Stylus

- Frequency response:20-20000 Hz
- Recommended tracking force:30 mN
- Output voltage:5 mV
- Terminal resistance:47 kohms

snk-10609050

19,64 € 17,00

S-15 STYLUS
Spherical Replacement Stylus

- Frequency response:20-20000 Hz
- Recommended tracking force:30 mN
- Output voltage:5 mV
- Terminal resistance:47 kohms

HEADSHELLS

snk-10605258



snk-10605259



snk-10605263



snk-10605262



Prod Code	Omschrijving	Prijs
snk-10605258	Universal Headshell Empty - Black	11,78 € 10,00
snk-10605259	Universal Headshell Empty - Silver	11,78 € 10,00
snk-10605263	Universal Headshell Empty with Weights - Black	19,64 € 17,00
snk-10605262	Universal Headshell Empty with Weights - Silver	17,73 € 15,00

tonar

SPECIALIST IN STYLI, CARTRIDGES AND ACCESSORIES FOR VINYL



OP ZOEK NAAR EEN NIEUWE NAALD VOOR UW HUIDIGE PLATENSPELER?

Tonar heeft meer dan 3000 platenspeler-naalden in hun assortiment, zo kunnen ze voor bijna elke platenspeler oud of nieuw een vervangnaald of volledig nieuwe cartridge aanbieden. Daarnaast hebben ze ook een uitgebreid gamma aan HiFi accessoires om ten volle van je platencollectie te genieten.

BEKIJK HUN CATALOGUS VANAF P. 19



acc-slipmattablecloth

€ 32,00

2 Tablecloth Slipmats + 4 Slip Sheets



acc-slipmat

14,99 € 13,50

Set of 2 Slipmats

- Available in various designs



amc-am020196

€ 36,30

ANTI-STATIC RECORD MAT

Carbon Fiber Felt Mat

Removes static charges from the record during playing for hiss and pop free listening. Improves soundstage, imaging, and tonal accuracy



ort-slipmat

€ 18,81

LIMITED EDITION SLIPMAT

High Quality Slipmat Matches Concorde MKII Series



aur-axisotone

€ 119,79

ISO-TONE**Turntable Isolation Platform**

- Creates A Cleaner, More Accurate Sound
- Decouples Turntable From Its Supporting Structure
- Reduces Acoustic Feedback

Auralex™
acoustics

luk-asb1

118,88 € 99,00

ASB-1 TT**Absorber For Turntables**

- High-quality and rugged
- Absorbs feedback and vibration
- Resistant from external interferences
- Compatible with any turntables similar to Technics SL 1200
- Rubber feet make sure the absorber always stands safely
- Absorbers from foam
- Outer plates from birch plywood
- Measurements: 46,5 x 36,2 x 5,5cm
- Made in Europe

LUKE

isn-isolationfeetm6x4

€ 181,50

ISOLATION FEET**High-end Shock Absorber Kit**

Isonoe Isolation System has been proven effective at blocking the transmission of vibration in a diverse array of applications, from classic turntables and valve amplifiers, to scientific apparatus. In the case of turntables, the ability to prevent feedback in high-SPL environments has enabled the isolation feet to become an industry standard within nightclubs

ISONOË

isn-bootsx4

€ 48,40

SORBOTHANE BOOTS**Rubber Boots for Isolation Feet**

Provides optimum seating for the balls in the base of the Isolation Feet. Recommended for nightclubs, where the turntable being supported may be subject to hard physical manipulation and needs to be firmly anchored in place

ISONOË



amc-am020202

€ 30,25

RECORD CLEANER SET**Cleaning, Stabilising and Anti-static Treatment**

- Contains 45ml Record cleaner fluid, Vinyl brush, Stylus cleaner and lint free cotton cloth
- Effectively removes dust, grit and particles
- Reduces stylus and record wear

**am**

amc-am020165

€ 14,52

RECORD CLEANER**Cleaning Liquid**

- 200ml non-abrasive and residue-free vinyl cleaning fluid
- Includes lint free cotton cloth
- Safely and efficiently eliminates dust, dirt and static buildup
- Cleans up to 1000 record sides

**am**

amc-am020172

€ 14,52

STYLUS CLEANER**Stylus Cleaning Solution**

- 20ml non-abrasive stylus cleaning solution and brush applicator
- Effectively removes dust, grit and particles worn from stylus tip
- Reduces stylus and record wear

**am**

amc-am020189

€ 14,52

ANTI-STATIC VINYL BRUSH**Ultra Fine Carbon Fibre Brush**

Anti-static, ultra fine carbon fibre brush. Effectively lifts dust, grit and particles to reduce friction without damaging your records.

**am**

Met Timecode of Digital Vinyl System (DVS) kunnen DJ's gebruik maken van DJ-software en digitale muziekbestanden, maar met draaitafels of traditionele DJ CD-spelers. De voordelen hiervan zijn het behoud van het gevoel van DJ'en met vinyl of CD-spelers, digitaal DJ'en mogelijk te maken zonder dat je je bestaande opstelling hoeft te vervangen, en digitaal kunnen DJ'en op vrijwel elke setup.

ran-seratosl4
~~1088,99~~ € 899,99

SCRATCH LIVE + SL4
Advanced Dual USB Interface For DJ's

- Inputs for four turntables or CD decks switchable in any combination.
- Two high-speed USB 2.0 ports for seamless DJ changeover and back-to-back performance.
- Aux Input for session recording or LiveFeed.
- 48 kHz and 96 kHz sample rate switch on the SL 4 rear.
- 10-in 10-out USB sound card with any software supporting ASIO or Core

RANE
ddj-ds1
~~483,99~~ € 399,00

DS1
Professional 2-Channel Serato DJ DVS interface

- Premium Digital Vinyl System (DVS) interface for Serato DJ
- Interfaces turntables and CD players using Serato NoiseMap with a Serato DJ-based digital music library
- Plug and play with Serato DJ and Serato DVS Expansion Pack no purchase necessary
- (2) sets of stereo RCA inputs and outputs for left and right decks
- Studio-grade 24-bit digital to analog conversion
- Supports 44,48 & 96kHz

DENON DJ
pio-interface2
~~299,00~~ € 285,00

INTERFACE-2
2-Channel Audio Interface For Rekordbox DVS

- Hoogwaardig geluid (44,1 kHz / 48 kHz / 96 kHz.)
- Een compacte en stevige behuizing
- Leds geven de signaalstroom weer
- incl. controle vinyl
- incl. key voor rekordbox dj en rekordbox dvs
- Stroomtoevoer via het net of via USB
- Stand-alone audio-interface
- Grote GND (aarde) aansluiting

Pioneer DJ

NAAST DE TIMECODE INTERFACES HEBBEN WIJ OOK ALLE NODIGE CONTROL VINYL EN CD'S IN ONS ASSORTIMENT.



ser-psblksg

27,83 € 19,36

12" SINGLE CONTROL VINYL**Official Control Vinyl**

Control Vinyl pressing for Serato DJ Pro and Scratch Live using Serato's NoiseMap™ Control Tone
Other colours and special designs available

**serato**

ser-psblk10

50,82 € 36,30

10" PAIR CONTROL VINYL**Official Control Vinyl**

Control Vinyl pressing for Serato DJ Pro and Scratch Live using Serato's NoiseMap™ Control Tone
Other colours and special designs available

**serato**

pio-rekordboxdvsvinyl

€ 15,99

RB-VS1-K**Control Vinyl**

The lightweight Control Vinyl and the rekordbox dvs Plus Pack go hand-in-hand to put smooth, low latency scratching at your fingertips. Use them to play and scratch digital files when you combine them with a turntable, like the PLX-1000 or PLX-500, and a compatible DJ mixer.

**Pioneer Dj**

pio-rekordboxdvsvinylred

49,00 € 40,00

RB-VD1**Control Vinyl**

Pair the lightweight RB-VD1 Control Vinyl with the rekordbox dvs Plus Pack to have smooth, low-latency scratching at your fingertips and choose from transparent, black, white, blue and red versions to match the colour of your gear or style.

The RB-VD1 Control Vinyl is sold in pairs.

**Pioneer Dj**

ran-twelve

967,99 € 799,99

TWELVE**Motorized 12" Platter Controller**

THE FIRST 12" MOTORIZED SERATO CONTROLLER. TRADITIONAL TURNTABLE FEEL FOR THE DIGITAL DJ

SOLID BUILD WITH PRECISION PERFORMANCE

- Solid steel casting and a aluminium platter
- Extreme precision : 3600 ticks of platter resolution for seamless performance
- 5.0 kfcM high-torque motor with high/low torque adjust

TRADITIONAL TOUCH, MODERN CONTROL

- True vinyl-like performance
- 8 hot-cue trigger
- Strip Search
- 4 decks of control so you can use one, two or more
- Flexible pitch range 8-16-50%

Combine 2 Rane TWELVE's with a Rane SEVENTY-TWO mixer for an ultimate Serato DJ turntablism setup with endless creative possibilities.

RANE

mwm-phaseessential

299,99 € 285,00

PHASE ESSENTIAL**Wireless DVS Controller**

CONTROL TRACKS PLAYING FROM A DJ SOFTWARE WITHOUT NEEDING TURNTABLE NEEDLES OR TIMECODE CONTROL VINYL.

Two audio remotes capture the turntable rotation information and wirelessly transmit it to a receiver that processes and sends it to your DVS setup. Phase offers an unprecedented communication quality and reactivity, and is completely unaffected by external disruptions and common DJ equipment issues.

- Aluminium housing with magnetic surface
- Robust and impact resistant
- 10-hour battery-life per Remote
- Rechargeable Lithium-ion battery built-in
- 2-hour charging over USB or power-supply
- 2 stereo RCA outputs
- USB connection to power and configure Phase
- 2.4 GHz signal radio frequency
- 32 bits / 96kHz audio support

Compatible with Serato DJ, Virtual DJ, Rekordbox & Traktor



VOORWOORD

Deze catalogus is ontworpen om U meer inzicht te geven in **wat een grammofoonnaald is** — op welke uiterlijke details U moet letten, hoe hij werkt, hoe U kunt vaststellen van welk fabrikaat hij is en door welke naalden U hem kunt vervangen. Als U even tijd neemt om deze pagina's te bestuderen, zal dat zowel op Uw omzetcijfers in naalden als op de tevredenheid van Uw klanten een stimulerende werking hebben!

De groef van een grammofoonplaat is in talloze kleine zig-zag-kronkelingetjes geperst. De grammofoon is een apparaat dat deze zig-zag-bewegingen van de groef in geluid omzet, "vertaalt".

Dit gebeurt door de groef met een naald af te tasten. De zig-zag-bewegingen die de naald bij z'n loop door de groef maakt worden overgebracht op een z.g. element. Dit element nu produceert een stroompje, waarvan de sterkte varieert met de bewegingen van de naald. Dit steeds van sterkte wisselende stroompje wordt nu door een versterker omgezet in stroomsterktevariëaties van een grootte-orde voldoende om een luidspreker geluid te laten voortbrengen.

Met nadruk wijzen wij erop, dat de enige verbindingsschakel tussen grammofoonplaat en pick-up de naald is. Is de naald versleten of beschadigd, dan zal dat resulteren in slechts gedeeltelijk of vervormd weergegeven geluid. Dat is één van de redenen waarom het zo belangrijk is dat de naald in goede staat verkeert.

Laten wij nu de naald zelf nog eens wat nader bekijken. In dwarsdoorsnede gezien, ziet de groef van de grammofoonplaat met de erop geplaatste naald er ongeveer zo uit:

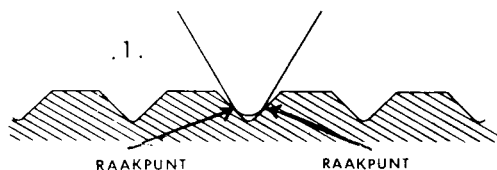

Zoals U ziet, heeft de naald geen scherpe, maar een afgeronde punt; de naald maakt alleen contact met de twee zijkanten van de groef. Als de grammofoonplaat draait, glijdt de naald langs deze twee contactpunten. Het aanvankelijk afgeronde naaldoppervlak langs deze twee punten zal, op den duur, vlak afslijten. (Zie tekening.) →

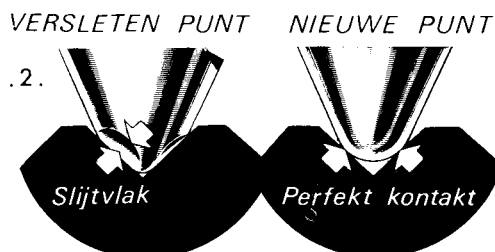

De plaats waar de nog afgeronde en de vlak afgesleten gedeelten van het naaldoppervlak samenkomen gaat nu een scherpe rand vormen, die op zijn beurt weer de zijkanten van de groeven gaat afslijten, waardoor een gedeelte van de scherpe zig-zag-vorm waarin de groef geperst is verloren gaat. Aangezien nu juist deze zig-zag-vorm de 'informatiebron' is voor het geluid en alle aspecten daarvan, zoals hoge en lage tonen, timbres, verschillende instrumenten, enz., betekent de vermindering ervan door een versleten naald eigenlijk dat er geluid van de plaat wordt afgesleten. Dat geluid is daarmee onherstelbaar verloren gegaan.

Het gevolg is dan ook dat zelfs de kostbaarste installaties en platen vrijwel waardeloos worden als ze gebruikt worden met een versleten naald! **IEDERE NAALD MOET REGELMATIG VERVANGEN WORDEN.** (Meer hierover later.)

Wij weten nu hoe een grammofoonnaald werkt en waarom hij vervangen moet worden. Welke procedure moeten wij nu volgen om onze klanten van de juiste vervangingsnaald te voorzien?

Er is tegenwoordig een grote verscheidenheid aan naaldtypen in omloop. Ieder type is ontworpen voor een bepaald element en past vaak alleen in dat element. Sommige naalden zijn "populairder" dan andere, omdat de elementen waarin deze naalden passen door veel fabrikanten van grammofoons gebruikt worden; vandaar dat er een relatief grote vraag naar deze naalden is. Uw bevinding zal waarschijnlijk zijn dat deze "populaire" naaldtypen (in aantal zo'n 12 tot 16) ongeveer 75% van Uw naaldomzet vormen. U moet daarom goed vertrouwd zijn met deze "populaire" typen.

De meeste klanten weten niet welke naaldsoort in hun installatie past. Het is in zo'n geval noodzakelijk dat U Uw klant uitlegt welke informatie hij U precies moet geven om U in staat te stellen hem de juiste vervangingsnaald te leveren.

1. De gemakkelijkste en meest directe manier om vast te stellen om welk naaldtype het gaat, is om de klant U het merk en nummer van zijn element te laten geven.

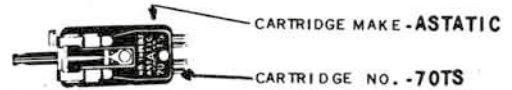

'U zoekt dan in de alfabetische lijst de elementenfabrikant op. Heeft U deze gevonden, dan zoekt U in de kleine hokjes boven aan naar het juiste elementnummer. Probeert U eens de Pathé Marconi MUCS. Als U goed heeft gezocht, dan vindt U ons bestelnummer 240.

Tonar replacement types for: PATHE MARCONI

51	53	MUCS; MCS	RC 5/6	STC-7; STC-S; STC-41	STEREO	ST-10 J	STC-2000 D
154 	155 	240 	156 	157 	158 	771 	157
917 	885 						

2. Een andere manier om een naaldtype vast te stellen is om Uw klant te vragen zijn oude naald mee te nemen, en U het merk van zijn platenspeler te vertellen. Dan kunt U door het vergelijken van de tekeningen in de alfabetische lijst met het meegebrachte naaldje, vaak ook tot identificatie komen.
3. U zou ook Uw klant kunnen vragen wat het merk en het nummer zijn van een eerder door hem gekochte naald — of welk naaldnummer er opgegeven wordt in de handleiding bij zijn grammofoon-installatie.
4. Heeft Uw klant al eens eerder een TONAR naald gekocht, dan weet hij het nummer.

441	Ronette CMT-102
442	B.S.R. ST-16/17 Fidelity Schneider ST-16/17
443	Dual CDS-650; 651; 660; 661 Dual CDS-670; CDS-671 Dual DN-6; 8; 62; 63; 64; 65; 85 Perpetuum Ebner PE-3000; CDS-650; CDS-651
444	Clean CM-500 Hape Piezo Y-930; YM-101
445	Kenwood N-23 Trio N-23
446	Teppaz MT-30



U kunt dan met behulp van dit nummer in de numerieke lijst te weten komen welk type het is.

Aan de hand van deze vier trefzekere methodes zult U in de meeste gevallen zeker kunnen zijn van de verkoop van een naald. Er zullen zich soms uiteraard ook gevallen voordoen, waarin U niet in staat zult zijn het naaldtype dat Uw klant nodig heeft vast te stellen, bv. door gebrek aan, of onjuiste informatie. Laat U door de paar keren dat dat gebeurt niet ontmoedigen; meestal zult U succes hebben en naarmate U meer ervaring krijgt zal de verkoop van naalden U steeds gemakkelijker afgaan.

Nu nog even een paar tips betreffende de levensduur van een naald.

Dikwijls wordt de vraag gesteld hoe lang een naald bruikbaar is, en waaraan je kunt merken dat een naald versleten is. Helaas is het zo, dat zodra men een hoge, scherpe ruistoon door de plaat hoort, het al te laat is — het kwaad is dan al geschied. Een betere manier om te bepalen in hoeverre een naald versleten is, is het bijhouden van de tijdsduur dat de naald in gebruik is geweest. Wil men een redelijke schatting maken van de te verwachten levensduur van een naald, dan moet men met veel factoren rekening houden: het gewicht van de draagarm, de toestand waarin de plaat verkeert, de hoeveelheid stof in de lucht, of het om een mono- of stereonaald gaat, en uit wat voor materiaal de punt bestaat — dit alles beïnvloedt de levensduur van de naald.

Wanneer bovengenoemde omstandigheden niet teveel van het gemiddelde afwijken, dan kunt U ongeveer het volgende aantal spelluren van Uw naald verwachten:

Punt gemaakt van :	Aantal spelluren:
Saffier	40—60 uren
Diamant	400—600 uren

N.B. — Uw vaardigheid in het verkopen van naalden zal sterk toenemen naarmate U meer vertrouwd raakt met Uw TONAR catalogus en U meer ervaring krijgt in het aflezen van nummers van elementen, naaldtypen, enz. Wij raden U dan ook aan om telkens wanneer U daartoe in de gelegenheid bent te oefenen door de arm van de grammofooninstallaties die U in de zaak heeft staan op te tillen en het merk en nummer van het element af te lezen. Raadpleeg daarna Uw TONAR catalogus en identificeer de gebruikte naald.

Op deze manier zult U snel de 'naalden-expert' in Uw omgeving worden, hetgeen niet alleen Uw verkoop van naalden ten goede zal komen, maar door de bredere klantenkring die U aantrekt zult U ook een grotere omzet kunnen bereiken in Uw andere artikelen.

INFORMATIE OVER CODERINGEN OP VERPAKKINGEN

In onderstaand lijstje vindt u alle gebruikte coderingen die op de verpakkingen van onze naalden kunnen voorkomen.

CODE OP VERPAKKING	OMSCHRIJVING
SS	SAFFIER STEREO
SN	SAFFIER NORMAAL (78 TOEREN)
DS	DIAMANT STEREO
DN	DIAMANT NORMAAL (78 TOEREN)
DE	DIAMANT ELLIPTISCH (BI-RADIAAL)
HYPEL	DIAMANT HYPER ELLIPTISCH (BI-RADIAAL)
ES	DIAMANT LINE CONTACT
SHIBA	DIAMANT SHIBATA GESLEPEN
D-SAS	DIAMANT NAKED BLOCK D-SAS GESLEPEN

Een aantal typen naalden die in onze verpakkingen voorkomen zijn feitelijk originele naalden (gefabriceerd door de fabriek die deze ook heeft ontworpen).

Deze naalden zijn herkenbaar aan de coderingen.

CODE OP VERPAKKING	OMSCHRIJVING
DS-OR	DIAMANT STEREO ORIGINEEL
DE-OR	DIAMANT ELLIPTISCH ORIGINEEL
SHIBA-OR	DIAMANT SHIBATA CUT ORIGINEEL

Voor de kristal en keramische elementen werden vroeger naalden gebruikt die omkeerbaar waren. Aan de ene kant zat dan een stereo naald en aan de andere een 78-toeren naald. Later, toen de 78-toeren platen schaars werden, ontstond de vraag om in plaats van de 78-toeren punt een stereo punt te monteren. Aangezien dit voor de fabriek geen extra kosten met zich meebracht, ontstonden de 'dubbel-stereo naalden'. De populaire typen van dit soort naalden worden nu standaard in 'dubbel-stereo' geleverd, en op speciaal verzoek met een 78-toeren punt. De minder populaire typen worden uitsluitend met 78-toeren en stereopunt geleverd.











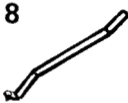

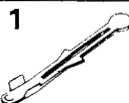
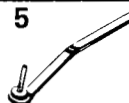
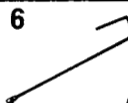

CODE OP VERPAKKING	OMSCHRIJVING
SN/SS	SAFFIER NORMAAL (78 TOEREN) / SAFFIER STEREO
SS/SS	SAFFIER STEREO / SAFFIER STEREO
SN/DS	SAFFIER NORMAAL (78 TOEREN) / DIAMANT STEREO
SS/DS	SAFFIER STEREO / DIAMANT STEREO

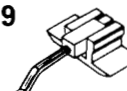
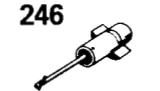
Ons leveringsprogramma is in een aantal artikelengroepen onderverdeeld. Aan de hand van het artikelnummer kunt U direct zien in welke groep het betreffende artikel valt.



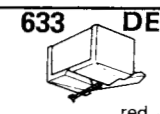
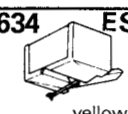
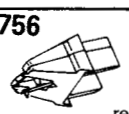
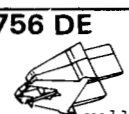

ARTIKEL NO.	ARTIKEL GROEP	OMSCHRIJVING
1 - 1999	0 OF 1	TONAR DIAMANTEN NAALDEN
6000 - 6999	0 OF 1	TONAR DIAMANTEN NAALDEN
2000 - 2999	2	PICK-UP ELEMENTEN
9100 - 9999	2	PICK-UP ELEMENTEN
3000 - 5999	3	ACCESSOIRES EN OVERIGE ONDERDELEN

In onze catalogus hebben wij veel originele naalden met hun nummers opgenomen om het vinden van de naald voor U gemakkelijk te maken. Ons totale programma originele naalden is echter veel groter en hiervoor verschijnt regelmatig een speciale lijst met het complete leveringsprogramma en de prijzen.





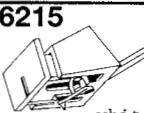
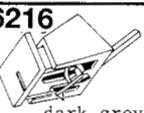
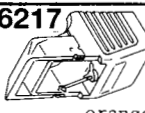
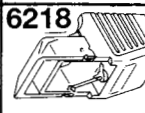
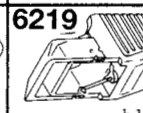













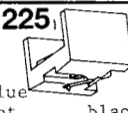
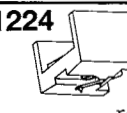

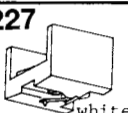

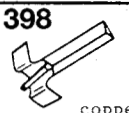
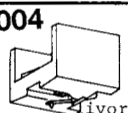

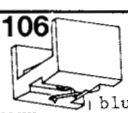



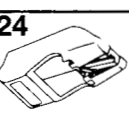
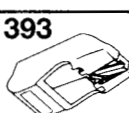

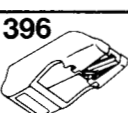
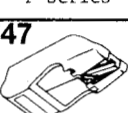
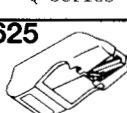
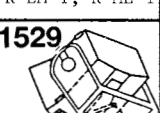

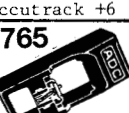
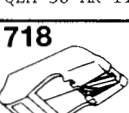
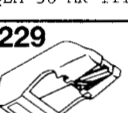



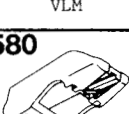

Tonar replacement types for: ACOS

GP-19 8 	GP-29 3 	GP-33 7 	GP-37 2 	GP-59 1 	GP-65; GP-67 5 	GP-71/3 6 	GP-73/1; 73/3 4 
GP-79 307 	GP-81 9 	GP-91 246 	GP-91-1-2-3 SC 353 	GP-93-94 364 	GP-95-96 377 	GP-104 392 	GP-104 455 transcription 
POWER POINT 339 	M-6 632 white 	M-6 E 633 DE red 	M-6 E/X 634 ES yellow 	M-7 756 red 	M-7 E 756 DE yellow 		

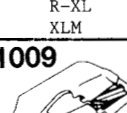
Tonar replacement types for: ACUTEX

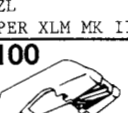
M-106 6201 white 	M-110 E 6202 DE dark red 	206 II 6215 white 	207 II 6216 dark grey 	310 III 6217 orange 	312 III 6218 red 	315 III 6219 blue 	320 III 6220 black 
--	--	---	---	---	---	---	--



























Tonar replacement types for: A.D.C.

R-7 E 1395 copper 	R-9 E 1001 blue 	R-1; R-10 I; I Mark II 1397 copper 	R-12 E 1002 no longer available 	R-15 E 10 E Mark IV 1003 black 	R-20; 220 422 red 	R-20 X; 220 X 560 ivory 	R-20 XE 220 XE 564 DE ivory 
R-25; 25 1225 blue dot black 	R-251; 25 1224 red 	R-253; 25 1226 white dot black 	R-26; 26 1227 white 	R-27; 27 1228 beige 	R-3; R-30 3; 3 Mark II 1398 copper 	R-50 XE 550 XE 1004 ivory 	R-60 XE 1392 ivory yellow dot 
R-90 XE 1106 ivory blue dot 	660 631 grey 	770 361 red 	R-778 78 r.p.m. 1786 l. blue 	K-series 624 dark blue 	R-K 3 E 1393 blue 	R-K 7 E 1394 blue 	R-K 8 E 1396 blue 
P-series 747 grey 	Q-series 625 l. blue 	R-LM-1; R-ML-1 1529 black 	R-LMA-1; LMA-1 accutrack 1117 black 	R-LMA-3; LME-3 accutrack +6 1765 black 	QLM-30 MK II 1718 grey 	QLM-30 MK III 1229 grey 	QLM-32 MK II 1716 grey 
R-SQ-32 QLM-32 MK III 1230 grey 	R-SQ-33 QLM-33 MK III 1231 grey 	R-SQ-34 QLM-34 MK III 1232 grey 	R-QLM-36 QLM-36 MK II 1391 grey 	R-Q-36 QLM-36 MK III 1068 grey 	VLM 580 black 	R-VL VLM MK II 1008 black 	R-SV VLM MK III 1783 black 
XLM 579 DE black 	R-XL XLM 1009 black 	R-ZD XLM MK II 1235 black 	R-ZL SUPER XLM MK II 1100 black 	R-SX; XLM MK III XLM MK 3 impr. 1233 black 	R-YX YX MK III 1635 black 	R-X-4 XL-400 1633 black 	R-XT II XT series II 1785 black 

CONTINUED

Tonar replacement types for: **A.D.C.**

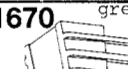
CONTINUED

R-Z 10 ZL-1000	R-SZ; ZLM ZLM improved	R-78, 78-RPM for: K;P;Q;QLM;XLM;VLM	R-L-3; L-3	R-L-4; L-4	R-L-5; L-5	R-Q-3; Q-3	R-Q-4; Q-4
1634  black	1234  black	1236  red 78 r.p.m!	1251  blue	1400  blue	1435  red	1385  blue	1401  red
R-S1 phase I Digital ser. 1	R-S2 phase II Digital ser. 2	R-S3 phase III Digital ser. 3	R-S4 phase IV Digital ser. 4	R-XM 1 INTEGRA XLM-1	R-XM 2 INTEGRA XLM 2	R-XM 3 INTEGRA XLM 3	R-SA ASTRION
1413  grey	1414  black	1415  black	1416  black	1800  black	1801  black	1802  black	1787  tr. clear
R-SX 5; SX-5	R-SX 5 E SX-5 E	R-PSX-10 PSX-10	R-PSX-20 PSX-20	R-PSX-30 PSX-30	R-PSX-40 PSX-40	R-TRX-1 TRX-1	R-TRX-2 TRX-2
6150  black	6150 DE  blue	1386  blue	1417  red	1418  white	1419  tr. blue	1430  gold	1431  gold
R-DC 90 S DC-90 S	R-XT III XT series III	R-XT IV XT series IV					
1670  grey	1803  black	1804  black					





















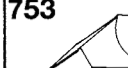

Tonar replacement types for: **ADMIRAL**

409 B 19-8							
10 							





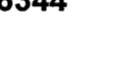

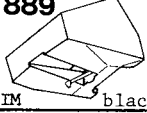
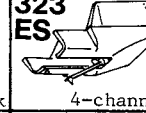
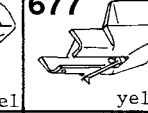
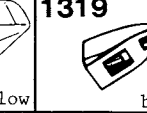
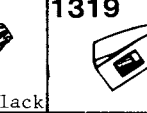
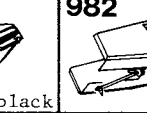
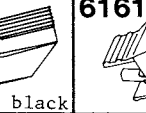

Tonar replacement types for: **AIMOR**

532  red							
--	--	--	--	--	--	--	--

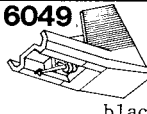
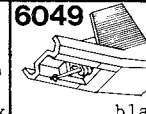
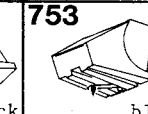
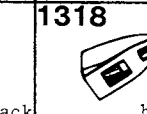
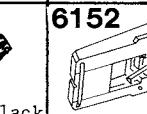
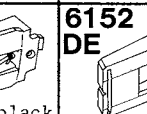
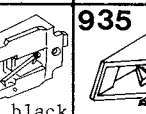
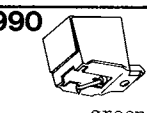
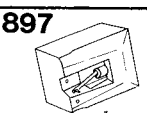
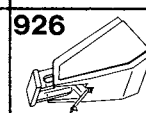
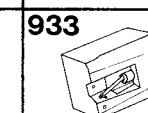
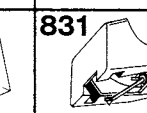
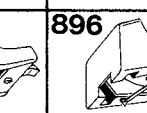
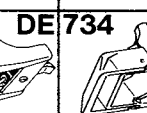
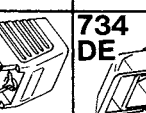
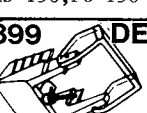

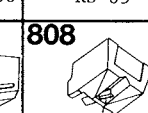
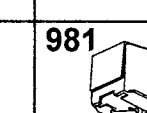
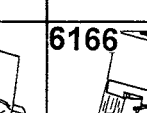
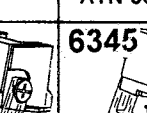
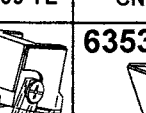
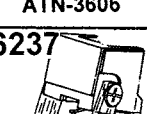
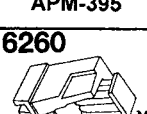

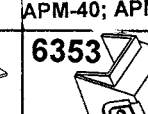
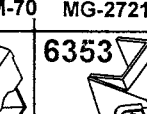

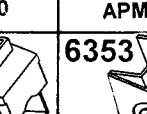
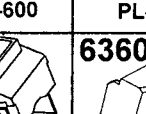
Tonar replacement types for: **AIWA**

AN-1 A	AN-2	STYLUS 5	AN-5; RN-5	AN-6	AN-7	AN-10	AN-F 10
813  red	6156  black	1319  black	832  red	757  green	831  yellow	6148  grey	6208  blue
AN-11	AN-20	AN-30	M-32	AN-35	AN-36	AN-87-43	AN-87-45
6263  l. grey	980  red	6014  blue	660  green	813  red	822  white	691  orange	753  black
AN-50	AN-60	AN-70	AN-71	AN-77 DY	AN-5080	AN-110	AN-501 C
957  black	953  white	935  black	758  black	6156  black	6344  black	6036  black	813  red

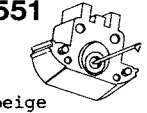
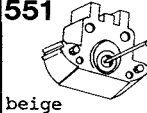

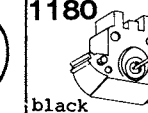
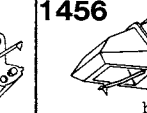
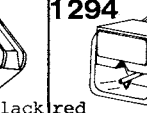
Tonar replacement types for: AKAI

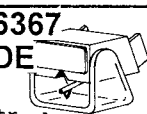
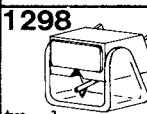
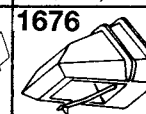
APN-2 571  white	RS-3 J 889  black	APN-4 323 ES  4-channel	APN-5 CN-2398 677  yellow	Stylus 5;LMB-5 1319  black	RS-5; SMB-5 1319  black	RS-7; PC-7 982  black	RS-10; PC-10 6161  black
Stylus 12 LMB-12 1318  black	RS-33; PC-33 6049  black	RS-35; PC-35 6049  black	RS-38 753  black	RS-41 1318  black	RS-50; PC-50 6152  black	RS-50E;PC-50E 6152 DE  black	RS-77 935  black
RS-82 990  green	RS-83 897  brown	RS-84 926  red	RS-85; PC-85 933  black	RS-90; PC-90 831  yellow	RS-95; PC-95 896 DE  black	RS-100;PC-100 734  black	RS-120;PC-120 734 DE  black
RS-150;PC-150 899 DE  black	RS-180;PC-180 6142 DE  black	RS-200;PC-200 1243  black	RS-65 808  green	981  white	6166  yellow	6345  yellow	6353  grey
ATN-3606 6237  grey	APM-395 6260  blue	CN-254 6366  black	APM-40; APM-70 6353  grey	MG-2721 6353  grey	APM-550 6353  grey	APM-600 6353  grey	PL-305 6360  black

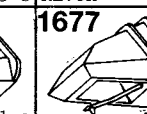
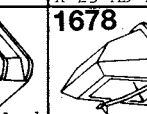
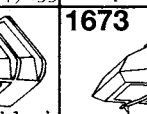
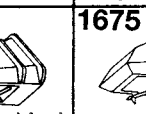

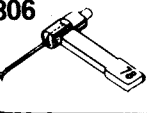

Tonar replacement types for: A.K.G.

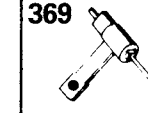
X2R; PU-2R 551  beige	X3E; PU-3E 551  beige	X-4; P-4; P-4 DP 1455  black	X-4E; PU-4E 1180  black	X-5ED; P-5 ED 1456  black	X6R; P6R 1294  red	X6E; P6E 1295  black	X7E; P7E 1296  tr.clear
X8E; P8E 6367 DE  tr.clear	X8S; P8ES 1298  tr.clear	X-10 S P-10 ED;P-10 S 1676  red	X-15 S P-15 MD;P-15 S 1677  blue	XD-20; P-20 MD REVOX 1677  black	X-25 S/P-25 S X-25 MD-24/.35 1678  black	X-8 ES P-8 ES Super Nova 1673  black	X-10 ST P-10 ED STUDIO 1675  red

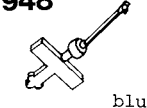
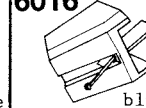
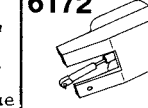
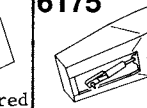

Tonar replacement types for: ALLPHON

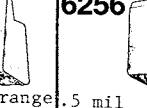
66 306 	69 404 	JEUNESSE 425 	PC-1 369 				
---	---	---	---	--	--	--	--

Tonar replacement types for: AMSTRAD

T-30 MS T-30 MD 980  red	T-30 MS T-30 MD 948  blue	6016  blue	TS-51/55 6172  red	TM-77 6175  red	N-900 C 900 C 725  .6 mil orange	N-900 D 900 D 6256  .5 mil grey	N-900 EX 900 EX 725 DE  yellow
--	---	--	---	--	---	---	--







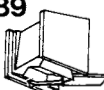
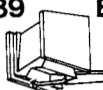



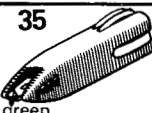
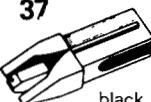
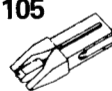



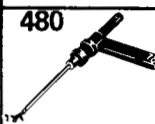
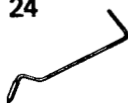
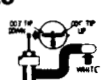
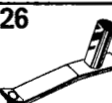

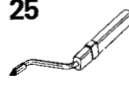



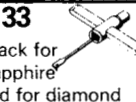





Tonar replacement types for: **ANDANTE**

P-38	P-76						
6270 black 	6272 DE tr. clear 						

Tonar replacement types for: **A + R / CAMBRIDGE**

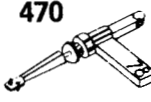

P-77	P-78						
789 red 	789 ES brown 						

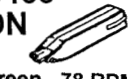
Tonar replacement types for: **ASTATIC**

13 T	81-T	91-T	N-7	N-8	N-14/215	N-17; 207	N-19; 223
35 green 	37 black 	105 white 	27 	28 	495 	479 	480 
N-29; G	N-30; 55; GCD	N-31; K	N-34; Q	N-35; R	N-36; L; T	N-37; U	N-38; 57; GC
24 	29 	26 	22 	383 	25 	36 	30 
N-39; A	N-41; N 42; 17-D	N-43; 15-D	N-45; 45-D	N-50; N-51; 133	N-52; N-53	N-54; N-55	N-56
23 	31 	33 black for sapphire red for diamond 	34 gold 	32 	39 	40 	41 
N-60	N-64	N-72	N-74	N-76	N-79	N-81	N-83
38 	248 	354 	289 	290 	312 	313 	314 
N-85	N-89/205	N-687	81T; 89T	81T; 89T			
355 	470 	271 	6464 red 	6465 DN green 78 RPM 			

Tonar replacement types for: **AUDIO EMPIRE, See: EMPIRE SCIENTIFIC**

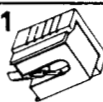
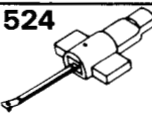
Tonar replacement types for: **AUDIO SONIC**

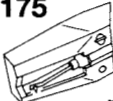
456 blue 	651 MM black/white 	524 	734 black 	6175 red 			
---	---	---	--	---	--	--	--











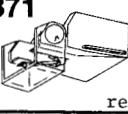

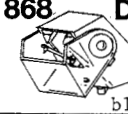

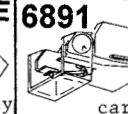
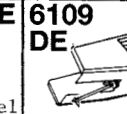
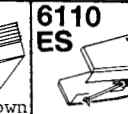
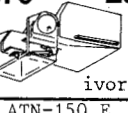
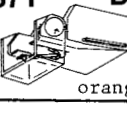
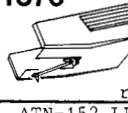
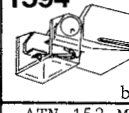
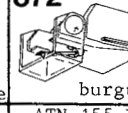
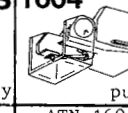
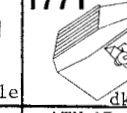
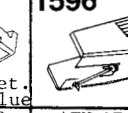
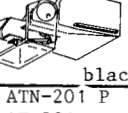

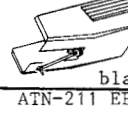
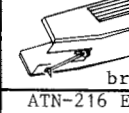
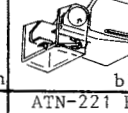
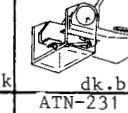
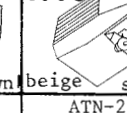
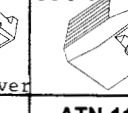



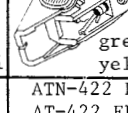
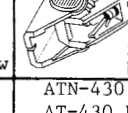
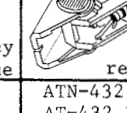
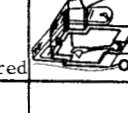
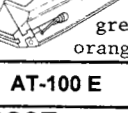

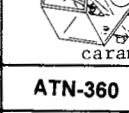
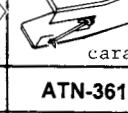
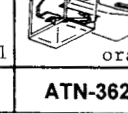
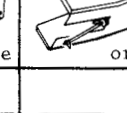
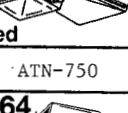
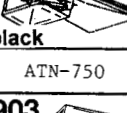
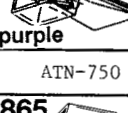
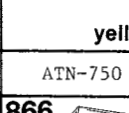
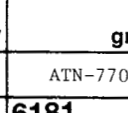
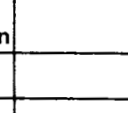
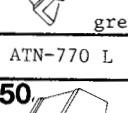
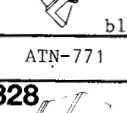
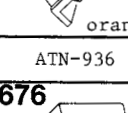
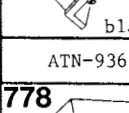
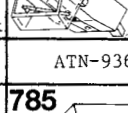
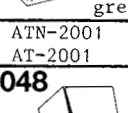
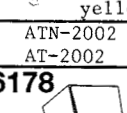
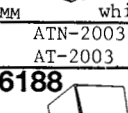
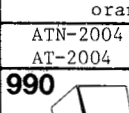
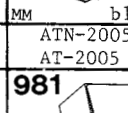
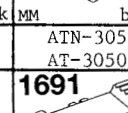
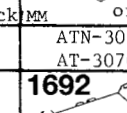
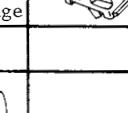
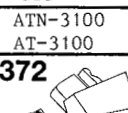

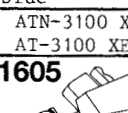

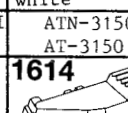
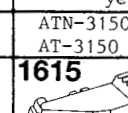
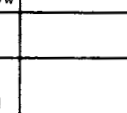

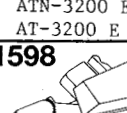
Tonar replacement types for: **AUDIO TECHNICA**

ATP-1	ATX-1	ATP-2	AT-3	ATP-3	AT-VM-3	ATX-3E	AT-3-5 D
1197  white ATN-UL 3 AT-UL 3	1306  red/grey AT-4-7 D	1198  white/blue AT-4-7 D	780  white ATP-N 4 ATP-4	1199  white/red ATP-N 5 ATP-5	671  yellow ATX-5 E	1307  blue/grey AT-6	6270  yellow ATP-N 6 ATP-6
1576  orange ATP-N 8 EP	6236  black MM ATP-N2	6280  orange MM ATN-DS3 YL	1582  red ATN-DS3	1583  blue ATN-DS7	1308  bronze/grey ATN-G5	296  white ATN-G5	1584  caramel ATS-12 C
1695  l. blue ATP-N 7	6870  AT-7	6872  yellow VM-8 7D MG-35 V	6874  black AT-10	6876  black AT-11	6878  red AT-11 E	1840  brown AT-11 S	1694  red AT-11 S
1694  red AT-12 E	729  black AT-12 S	571  white AT-12 Sa	568  red AT-12 XE	677  yellow AT-13 E	741 DE  green AT-13 Ea	894  white AT-13 Ea/X	847  grey AT-14 S
748 DE  blue AT-14 Sa	620 shibata  ivory AT-15 S AT-15 Sa	782 shibata  white AT-15 SS	781 DE  l. brown AT-15 XE	783 DE  orange AT-20 SL AT-20 SLa	794 DE  orange/red AT-20 SS	806 DE  green AT-21	619 ES  red AT-22; 23a
796 shibata  lilac AT-24	1239  black AT-25	1239  black AT-30	709 DE  black AT-30 E	1240  black AT-30 HE	1240  black AT-31 E	398 DE  grey AT-33; AT-35	1269  silver AT-VM 35
1241  silver ATN-E 50	1241  silver AT-51; 52; 53	1243  black AT-51 E; 52 E AT-53 E	1243  silver AT-55	1481  grey AT-55 XE	1378  blue AT-57 XE	1220  yellow AT-59 XE	572  red ATN-61 AT-61
1687  met. green ATN-61 E AT-61 E	904  black ATN-61 XE AT-61 XE	904 DE  black AT-66	542  white ATN-70 AT-70	904 DE  black ATN-70 L AT-70 L	904 DE  black ATN-E 70	904 DE  black ATN-71 AT-71	1585  grey ATN-71 E AT-71 E
1586  grey ATN-72 AT-72	1590  grey ATN-72 E AT-72 E	398  grey ATN-90 AT-90	795  red ATN-E 90 AT-E 90	915  white ATN-91 AT-91	1688  met. blue ATN-93 AT-93	758  yellow ATN-95 E AT-95 E	768 DE  green ATN-101 P AT-101 P
895  brown ATN-101 EP AT-101 EP	760 DE  blue ATN-102 P AT-102 P	6182  grey ATN-102 EP AT-102 EP	1776  met. red ATN-101 EP AT-101 EP	974  yellow ATN-101 EP AT-101 EP	898  yellow ATN-101 EP AT-101 EP	6127 DE  green ATN-101 EP AT-101 EP	6126  yellow ATN-101 EP AT-101 EP
6189 DE  green ATN-101 EP AT-101 EP	927  grey ATN-101 EP AT-101 EP	986 DE  green ATN-101 EP AT-101 EP					

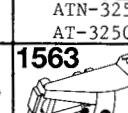
CONTINUED

Tonar replacement types for: **AUDIO TECHNICA**

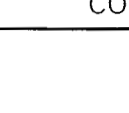
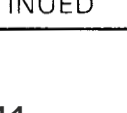
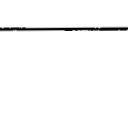









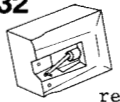







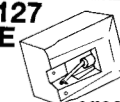
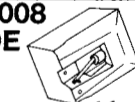



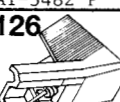
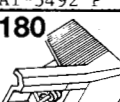

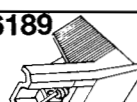
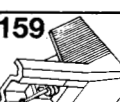
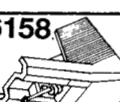
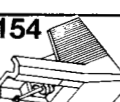

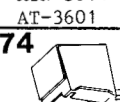

CONTINUED

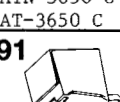
AT-103 soundruger	ATN-105 AT-105	ATN-110 E AT-110 E	ATN-112 EP AT-112 EP	ATN-115 E AT-115 E	ATN-120 E AT-120 E	ATN-122 EP AT-122 EP	ATN-122 LP AT-122 LP
871  red	867  yellow	868 DE  blue	979/DE  blue	6120 DE  smoke grey	6891 DE  caramel	6109 DE  brown	6110 ES  ivory
ATN-125 LC AT-125 LC	ATN-130 E AT-130 E	ATN-132 EP AT-132 EP	ATN-135 E AT-135 E	ATN-140 LC AT-140 LC	ATN-140 ML AT-140 ML	ATN-ML 140	ATN-142 LP AT-142 LP
870 ES  ivory	871 DE  orange	1376  red	1594  blue	872 ES  burgundy	1604  purple	1771  met. dk. blue	1596  blue
ATN-150 E AT-150 E	ATN-ML 150	ATN-152 LP AT-152 LP	ATN-152 MLP AT-152 MLP	ATN-155 LC AT-155 LC	ATN-160 ML AT-160 ML	ATN-ML 170 AT-ML 170	ATN-ML 180 AT-ML 180
1608  black	1772  met. dk. grey	1377  black	1624  brown	873 ES  black	1480  dk. brown	1773  beige silver	1774  gold
ATN-201 P AT-201 P	ATN-201 EP AT-201 EP	ATN-211 EP AT-211 EP	ATN-216 EP AT-216 EP	ATN-221 EP AT-221 EP	ATN-231 LP AT-231 LP	ATN-261 AT-261	ATN-113
1587  grey black	1588  grey ivory	1589  grey orange	1590  grey caramel	1591  grey yellow	1592  grey blue	1693  red/red	6348  orange
ATN-312 EP AT-312 EP	ATN-312 HEP AT-312 HEP	ATN-312 PBK AT-312 PBK	ATN-420 E AT-420 E	ATN-422 EP AT-422 EP	ATN-430 E AT-430 E	ATN-432 EP AT-432 EP	
1409  grey orange	1593  grey red	1407  black green	1778  caramel	1779  caramel	1780  orange	1781  orange	
AT-100 E	AT-150 MLX	AT-440 MLa	ATN-360	ATN-361	ATN-362		
6897  red	1949  black	6838  purple	6394  yellow	6395  green	6396 DE  blue		
ATN-750	ATN-750	ATN-750	ATN-750	ATN-770			
864  grey	903  blue	865  orange	866  black	6181  red			
ATN-770 L	ATN-771	ATN-936	ATN-936	ATN-936	ATN-952	ATN-952	AT-892
850  grey	828  yellow	676  white	778  orange	785  black	771  black	764  orange	928  black
ATN-2001 AT-2001	ATN-2002 AT-2002	ATN-2003 AT-2003	ATN-2004 AT-2004	ATN-2005 AT-2005	ATN-3050 AT-3050	ATN-3070 AT-3070	
6048  violet	6178  blue	6188  blue	990  green	981  ivory white	1691  yellow	1692  red	
ATN-3100 AT-3100	ATN-3100 E AT-3100 E	ATN-3100 XE AT-3100 XE	ATN-3100 XE/II AT-3100 XE/II	ATN-3150 AT-3150	ATN-3150 E AT-3150 E		
1372  black	1603  black	1605  black	1607  blue	1614  white	1615  white		
ATN-3200 AT-3200	ATN-3200 E AT-3200 E	ATN-3200 XE AT-3200 XE	ATN-3200 XE/II AT-3200 XE/II	ATN-3230 AT-3230	ATN-3250 AT-3250	ATN-3250 E AT-3250 E	
1609  black	1598  black	1446  black	1562  grey	976  black	1563  ivory	1595  ivory	

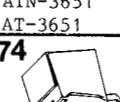
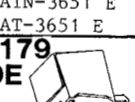
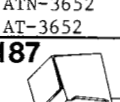
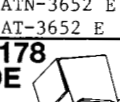
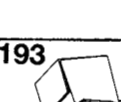
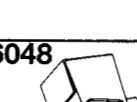
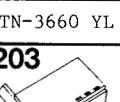
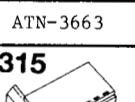
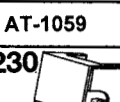
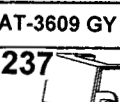
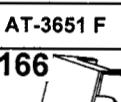
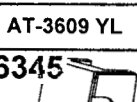
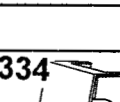
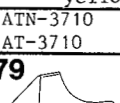
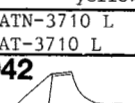
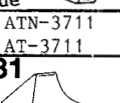
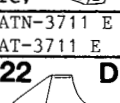
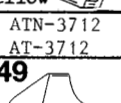
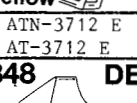
CONTINUED

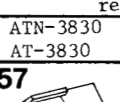
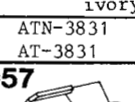
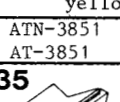
Tonar replacement types for: AUDIO TECHNICA

CONTINUED

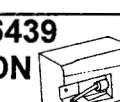

ATN-3400 AT-3400	ATN-3400 C AT-3400 C	ATN-3401 AT-3401	ATN-3410 AT-3410	ATN-3450 AT-3450	ATN-3450 C AT-3450 C	ATN-3450 L AT-3450 L	ATN-3451 AT-3451
832  red	6186  dk. grey	851  grey	898  yellow	832  red	6186  dk. grey	851  grey	898  yellow
ATN-3451 E AT-3451 E	ATN-3452 E AT-3452 E						
6127 DE  green	6008 DE  blue	925  tr.violet					
ATN-3472 P AT-3472 P	ATN-3472 EP AT-3472 EP	ATN-3482 P AT-3482 P	ATN-3492 P AT-3492 P	ATN-3492 EP AT-3492 EP			
6111  ivory	6111 DE  ivory	6126  yellow	6180  orange	6180 DE  orange	6189  l. green	6159  dk. green	6158  dk. blue
6154  red	6063  l. blue						
ATN-3600 AT-3600	ATN-3600 C AT-3600 C	ATN-3600 L AT-3600 L	ATN-3601 AT-3601	ATN-3626 AT-3626	ATN-3650 AT-3650	ATN-3650 C AT-3650 C	ATN-3650 L AT-3650 L
917  red	991  dk. grey	981  ivory	974  yellow	981  ivory	917  red	991  dk. grey	981  ivory
ATN-3651 AT-3651	ATN-3651 E AT-3651 E	ATN-3652 AT-3652	ATN-3652 E AT-3652 E				
974  yellow	6179 DE  green	6187  brown	6178 DE  blue	6193  turquoise	6048  dk. violet		
ATN-3660 YL	ATN-3663	AT-1059	AT-3609 GY	AT-3651 F	AT-3609 YL		
6203  yellow	6315  yellow	6230  blue	6237  grey	6166  yellow	6345  yellow	6334  black	
ATN-3710 AT-3710	ATN-3710 L AT-3710 L	ATN-3711 AT-3711	ATN-3711 E AT-3711 E	ATN-3712 AT-3712	ATN-3712 E AT-3712 E	ATN-3721 AT-3721	
879  red	942  ivory	831  yellow	922 DE  green	849  brown	848 DE  blue	900  yellow	
ATN-3830 AT-3830	ATN-3831 AT-3831	ATN-3851 AT-3851					
957  black	957  black	935  black					
AT-91 78 RPM	AT-3400 78 RPM	AT-3472 78 RPM	AT-95 78 RPM				
6378 DN 	6439 DN 	6436 DN 	6439 DN 				

Tonar replacement types for: **AUREX, See: TOSHIBA**





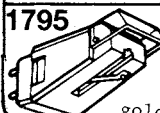
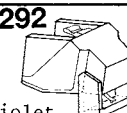
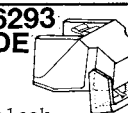
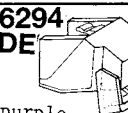
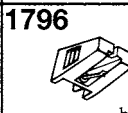

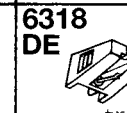
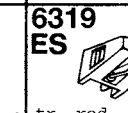





Tonar replacement types for: **AVNET**

ATN-3626							
981  1. grey							

Tonar replacement types for: **AZDEN**

GM-1 E	YM-10 C	YM-10 E	YM-10 VE	YM-P-20 E	YM-P-50 C	YMP-50 E	YMP-50 VL
1795  gold	6292  violet	6293 DE  black	6294 DE  purple	1796  blue	6295  clear	6318 DE  tr. blue	6319 ES  tr. red

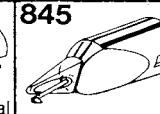
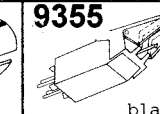
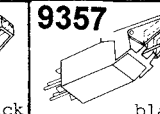
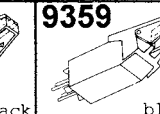
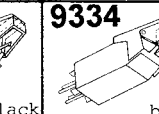
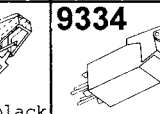
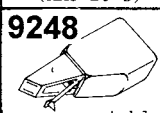
Tonar replacement types for: **BANG & OLUFSEN**

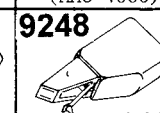
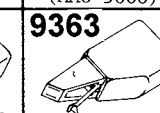
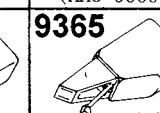
B & O	PROFESSIONAL	350 R; 72	SP-I; SP-II	SP-6/7	SP-6/7	SP-8/9	SP-8/9
42 	43 	44 	45  red	315  stylus only black	340  complete nickle	315 DE  stylus only black	340 DE  complete gold
SP-10	SP-12	SP-14	MMC-1	MMC-2	MMC-3	MMC-4	MMC-5
843  naked diamond	844 DE  naked elliptical	845  black	9355  black	9357  black	9359  black	9334  black	9334  black
MMC-10 E (MMC-20 S)	MMC-20 S (MMC-3000)	MMC-20 E (MMC-4000)	MMC-20 EN (MMC-5000)	MMC-20 CL (MMC-6000)			
9248  nickle	9248  nickle	9248  nickle	9363  nickle	9365  nickle			

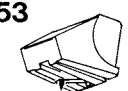

Tonar replacement types for: **BARCO**

753  black							
--	--	--	--	--	--	--	--

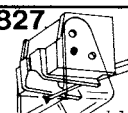
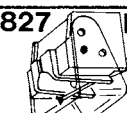
Tonar replacement types for: **BELLEXX**



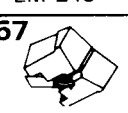

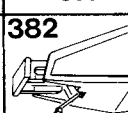
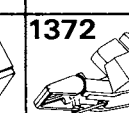
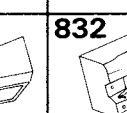
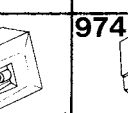
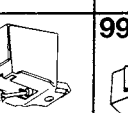
BX-50	BX-50 E						
827  blue	827 DE  red						

Tonar replacement types for: **BLAUPUNKT**

EM-240	P-60	305 M	ATN-3100	CN-5431	GP-330		
757  tr. green	651  MM black/white	382  blue	1372  black	832  red	974  yellow	994  black	

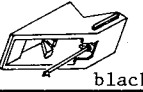
Tonar replacement types for: **BOHLAND AND FUCHS, See: SUPRAPHON**

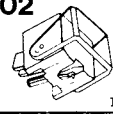

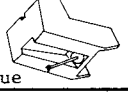

Tonar replacement types for: **BRANDT**

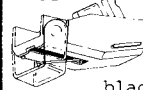
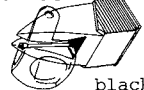
				FF-15 O MK II	QLM-30 MK III	L-3	L-4
904 DE  black	935  black	758  yellow	917  red	802  red	1229  grey	1251  blue	1400  blue

Tonar replacement types for: **BRAUN**

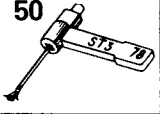
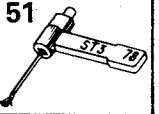
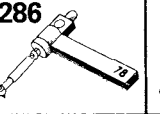
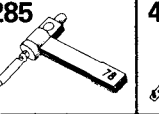
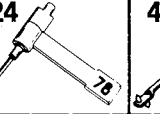
MAG 1 E	MC-1 E MC-2 E	MAG 2 E					
776 DE  black	1243  black	1445  black					

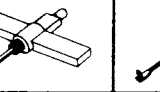
Tonar replacement types for: **B.S.R.**

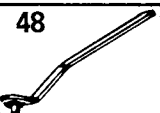
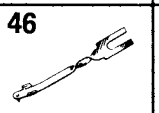
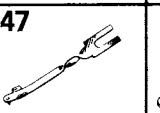
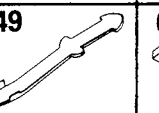
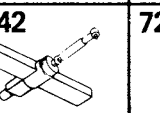
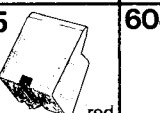
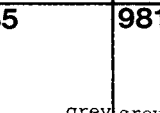
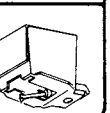



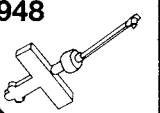
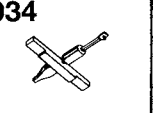

ST-3; ST-4	ST-5; ST-6; ST-7	ST-8; ST-9	ST-10	ST-12/14/15	ST-16/17	ST-19; ST-22	ST-20/21
50 	51 	286 	285 	424 	442 	523 	556 
TC 4	TC 8	TC 8 STEREO	TC 12	ST-23		S-1; SN-1	ATN-3600 L
48 	46 	47 	49 	642 	725  red	6085  grey	981  grey

Tonar replacement types for: **BYNATONE**

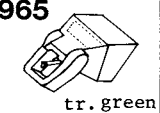
948 	934 						
---	---	--	--	--	--	--	--

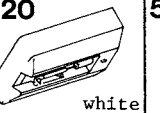
Tonar replacement types for: **CAMBRIDGE, See: A + R / CAMBRIDGE**

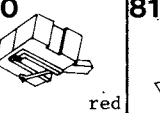
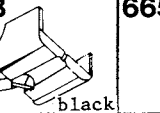
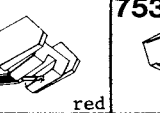
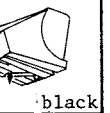
Tonar replacement types for: **C.E.C.**

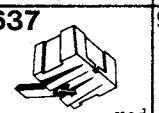
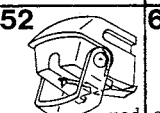
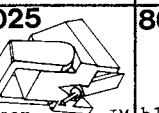
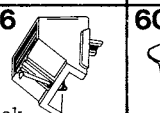
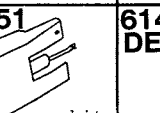
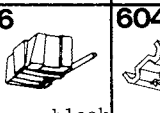
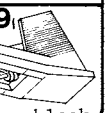
RS-3	MC-5	MC-6 S	MC-7	MC-8	MC-10	MC-11	MC-16
965  tr. green	576  grey	920  white	577  black	320  red	818  black	665  red	753  black
MC-17	MC-20	MC-45	ST-630	ATN-750		MC-20 ES	N-103
909  black	637  red	952  red	6025  clear IM	866  black	6051  white	6146 DE  black	6049  black

Tonar replacement types for: CLEAN

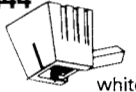
CM-500							
444  white							

Tonar replacement types for: CLIFTON

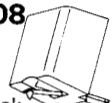
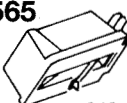
clifton	CLIFTON						
1108  black	565  lilac						

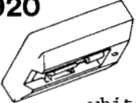
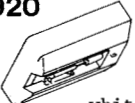

Tonar replacement types for: COBRA

250	520						
920  white	920  white						

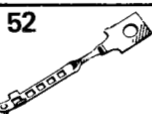
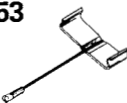

Tonar replacement types for: COLLARO

PX	STUDIO						
52 	53 						

Tonar replacement types for: COMPASS

ATX-1	ATX-3 E	ATX-5 E					
1306  red/grey	1307  blue/grey	1308  bronze/grey					

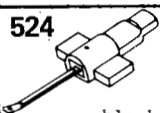
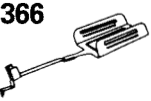

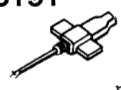
Tonar replacement types for: CONER

RCS STEREO	RCQ MONO	TESTINA RC-1	R-608 RCS				
524  black	366 	6070  copper	6191  red				



Tonar replacement types for: **CONNOISSEUR**

SCU-1							
358 							

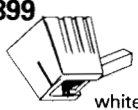

Tonar replacement types for: **CONVER**

B-60-100	STEREO						
394 	252 						



Tonar replacement types for: **CORAL**

V-7000; V-30 D	555-5	666 EX					
399  white	334  black	6005 DE  white					

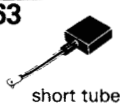

Tonar replacement types for: **COSMO**

COSMO	COSMOS G 62-30 M 23	G 62-30 M 23					
252 	394 	563  short tube					

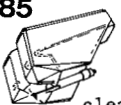
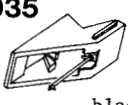
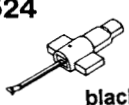

Tonar replacement types for: **CONTINENTAL EDISON**

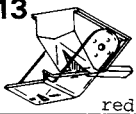
758  yellow	832  red	781 DE  brown	885  clear	935  black	524  black		

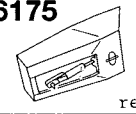
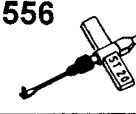

Tonar replacement types for: **CROWN**

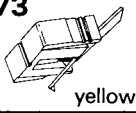
DT-36			ST-21 D; SHC-6100				
813  red	801  black	6175  red	556 				

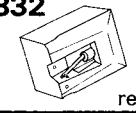
Tonar replacement types for: **CYBERNET**

573  yellow	822  white	832  red					
---	--	--	--	--	--	--	--

Tonar replacement types for: **DAEWOO**

974  yellow	6175  all plastic	6240  dark blue					
---	---	---	--	--	--	--	--

Tonar replacement types for: **DARLING**

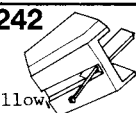
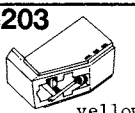
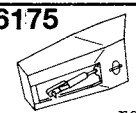
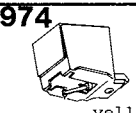
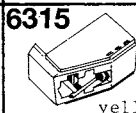
M-22	ATN-3660 YL		DL-32 E	ATN-3663			
6242  yellow	6203  yellow	6175  red	974  yellow	6315  yellow			

Tonar replacement types for: **DECCA**

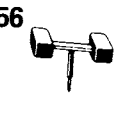
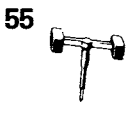
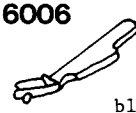
H	XMS	FF SS	DERAM				
56 	55 	1326* NO LONGER AVAILABLE	6006  blue				

* = Naaldremplacering voor deze elementen zijn alleen leverbaar na inlevering van het oude element.
Replacement needles for these cartridges are only available when the old cartridge is returned to us.

Tonar replacement types for: **DENON, See: JAPAN COLUMBIA**

Tonar replacement types for: **DIATONE, See: MITSUBISHI**

Tonar replacement types for: **DIGITRACK (BY: ORTOFON)**

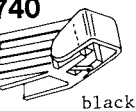
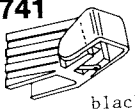
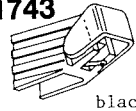
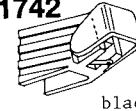
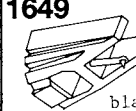
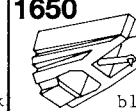
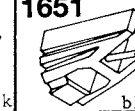
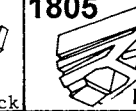
25 S	25 SP	50 E	50 EP	DIG 280 E	DIG 380 NE	DIG 450 SE	S
1740  black	1741  black	1743  black	1742  black	1649  black	1650  black	1651  black	1805  black

Tonar replacement types for: **DREHER + KAUF**

101							
1093  black							

Tonar replacement types for: **DUAL**

CDS-1	DN-1	CDS-2/3	DN-3	DN-4	DN-5;55;56 CDS-630	DN-6;62;63;64	DN-8
57 	59 	58  blue	60  brown	61  green	253 	443 	443 
DN-22	DN-23; 43	DN-24	DN-26; 45	DN-32	DN-34	DN-65	DN-70 CDS-700
236  red	66  gold	62  silver	63  red	64  red	65  silver	443 	504 
M-75 type D M-71 MB-D	M-73 M-G M-75 M-G	DN-85	DN-90; 95 DN-96	DN-110 MCC-110	DN-120 MCC-120	DN-140 S ULM-40 S	DN-145 S ULM-45 S
387  beige	386  grey	443 	67  red	1313  black	1374  grey	911  black	970  black
DN-145 E ULM/TKS 45E	DN-149 S TKS-49 S	DN-150 E ULM/TKS 50E	DN-152 E TKS-52 E	DN-155 E ULM/TKS 55E	DN-160 E ULM/TKS 60E	DN-165 E ULM-65 E	DN-166 E ULM-66 E
970 DE  black	6030  black	1286  black	6030 DE  black	6033 DE  black	6034 DE  black	1405 DE  black	1406  black
DN-201 DMS-200	DN-202 DMS-200	DN-211 DMS-210	DN-212 DMS-210	DN-221 DMS-220	DN-222 DMS-220	DN-235 DMS-235	DN-236 TKS/DMS 236/238
1012  red	1285 DN  78 R.P.M.	732  black	1411 DN  78 R.P.M.	820  red	1328  78 R.P.M.	981  white	6045  black
DN-237 TKS-237	DN-239 DMS-239	DN-241 DMS-240 E	DN-242 DMS-242 E	DN-301;302 SP-1	DN-305;306 M-44 MG	DN-311 V-15 D/AC	DN-314; DN-315 V-15 PD/1
969  black	981  white	1183  orange/brown	821DE  green	45  red	267-7  white	465  grey	275  black
DN-320	DN-325	DN-330 M-91 MG-D	DN-340 DM-101 M-G	DN-345 DM-103 M-E	DN-350 M-20 E	DN-352 V-15 III LM	DN-353 FF-15 MK II D
386  grey	387  beige	401  grey	615  red	623 DE  yellow	1036  black	584 DE  black	1181  red
DN-360 M-95 G-LM	DN-362 D-105 ED	DN-380 E TKS-380 E	DN-390 E TKS-390 E	DN-450 MMP-450	CDS-660; 661 CDS-650; 651	CDS-670;671	DN-20 NE OMB-20
678  grey	762 DE  black	537DE  black	6046 DE  black	6049  black	443 	443 	1631  black
N-20 EO F-20 EO	DN-105 soundburger	DN-167	DN-411	MMD-340	MMD-345	MMD-360 E	DN-245 DMS-245
1546  black	1529  black	1558 DN  black	1549  black	2473 *  black	2474 *  black	2475 *  black	1630  black
DN-249 E	DN-251 S	DN-251 E	DN-163 E	DN-166E; DN-168E	DN-34 MMD-340; MMD-345		
1736  black	1829  black	1831  black	1405  black	1406  black	1902  black		

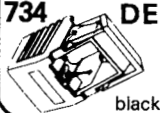

Tonar replacement types for: **EAGLE**

P 750 E							
734 DE  black							

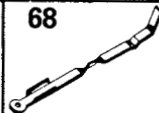
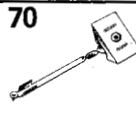
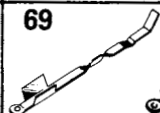
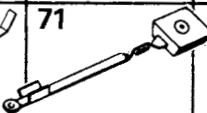



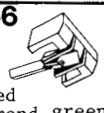
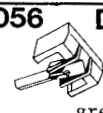
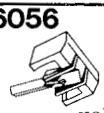

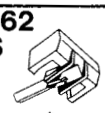



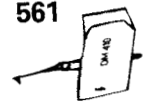

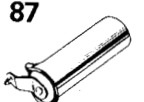



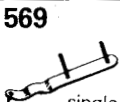

Tonar replacement types for: **EDEN**

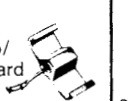
CLARVILLE	OLD MODEL	STEREO	59	62			
72 	68 	70 	69 	71 			

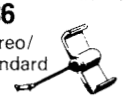

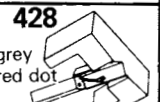
Tonar replacement types for: **E.E.I.**

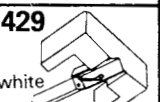
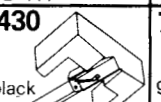
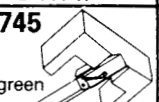
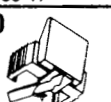
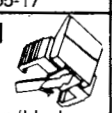
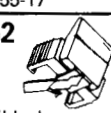
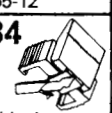
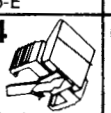
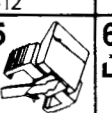
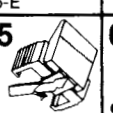
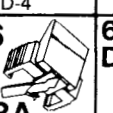
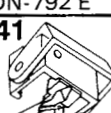
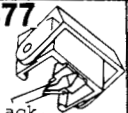
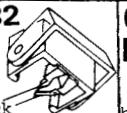
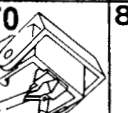
E.E.I.-300 H	E.E.I.-400	E.E.I.-500	E.E.I.-700	E.E.I.-800			
6056  naked diamond green	6056 DE  green	6056 ES  yellow	6057 ES  black naked diamond	6162 ES  tr. red			

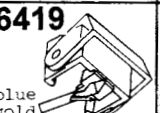
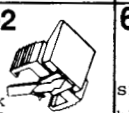
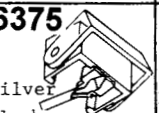
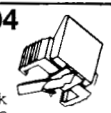



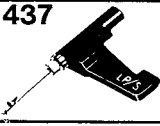
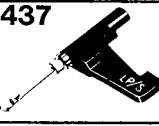
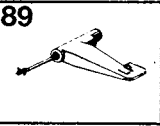
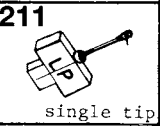
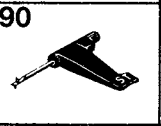
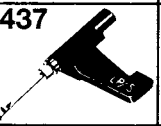
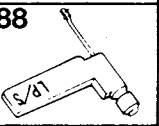
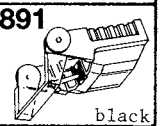

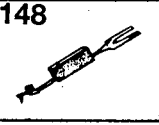
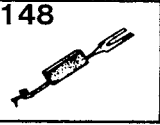
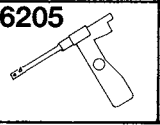
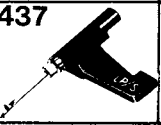







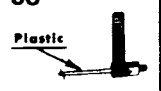

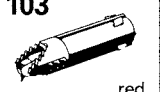
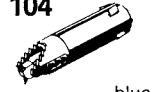

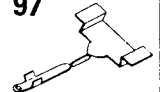
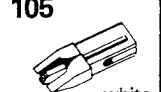

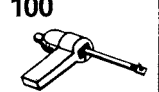
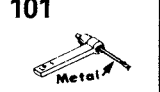
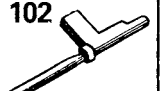

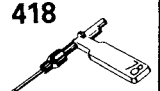
Tonar replacement types for: **ELAC**

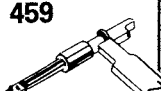
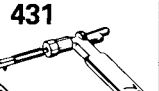
DM-240	DM-410	KST-2	MST-2	SM-101	SM-103	SM-107; SM-110	SN-11
341 	561 	75 	87 	77  stereo	79  stereo	82 	569  single tip
SN-12	SNM-9; SMM-9	SNM-14	SNM-100	SNM-102	SNM-104	SNM-106; 112; 406; KST-112	SNM-402
74 	73 	81 	76  stereo/standard	78  stereo/standard	80  stereo/standard	84 	86  stereo/standard
STS-210	STS 244-C D 244-C	STS 244-17 D 244-17	STS-322 STS-310	STS 344 D 344	STS 444 D 444	STS 144-17 D 144-17	STS 155-17 D 155-17
83 	427  grey	428  grey red dot	85 	429  white	430  black	745  green	750  black
STS 255-17 D 255-17	STS 355-17 D 355-17	STS 455-12 D 455-12	STS 455-E D 455-E	STS 555-12 D 555-12	STS 555-E D 555-E	STS 655 D-4 D 655 D-4	ESG-792 E DN-792 E
751  green/black	752  red/black	6384  gold/black	6384 DE  gold/black	6385  gold/green	6385 DE  gold/green	6386  SHIBA	6041 DE  black
ESG-793 (E) DN-793 E	ESG-794 (E) DN-794 E	ESG-795 (E) DN-795 E	KST-115	DN-796 H shibata	D-155 S	DN-791	D-355 S
6377  black	1382  black	6370 DE  black	82 	6419  blue gold	1702  black white	6375  silver black	1704  black white

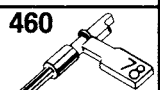
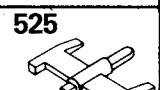
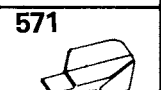
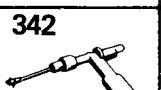

Tonar replacement types for: **ELECTRONIC REPRODUCERS**

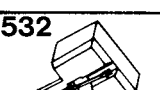
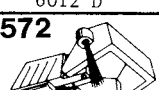
ERC-2 SB 437  450 M	ERC-2 SX 437  ERC-750	ER-5 MX 89  ERC-800	ER-5 MX 1 211  single tip ERC-900	ER-5 SB 90  ERC compat C	ERC-5 MB 437 	ER-60 88  S/41	ER-312 X 891  black
725  red	148 	148 	6205 	437 			





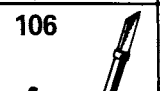

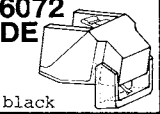

Tonar replacement types for: **ELECTRO VOICE**

10; 14; 34; 4130 91 	16; 16 TT 92 	21 93 	26 94 	31; 2606 95 	37; 72; 2614 98 Plastic 	37; 38; 47; 72 2626 343 	47; 2614; 2615 287 
51 103  red	56 104  blue	57; 2610 96 	58; 2611 97 	76 105  white	117; 131; 148 2616 99 	122 to 125 100 	32; 141; 149; 2617 101  Metal
147; 2621 102 	169; 2622 237 	2630; 5015 407 	2632; 5018 418 	2634; 5051 408 	2636; 5080 459 	2637; 5076 431 	2638; 5081 432 
2639; 5082 433 	2640; 5078 434 	2641; 5083 460 	2647 525 	2660 571 	5000 342 	EV 194; 2623 254 	EV 198/199; 2624 255 
2649; 5600 D 532  red	2671 D 6012 D 572  red	81 D 35 					

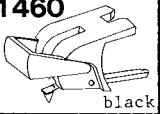
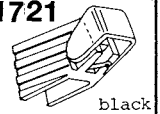
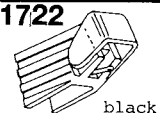
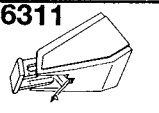
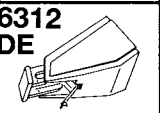

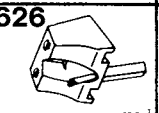
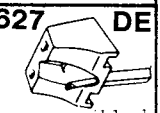
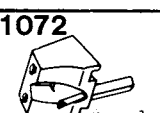

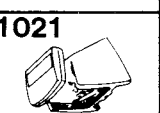
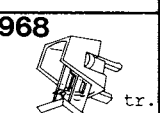
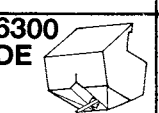
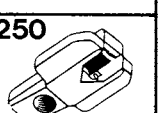
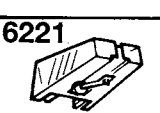
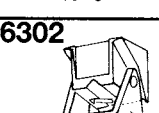
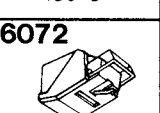
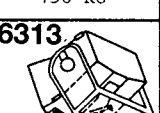
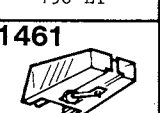
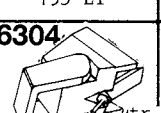
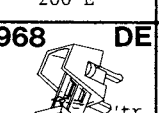
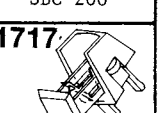
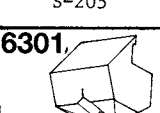
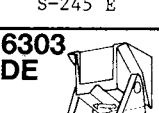
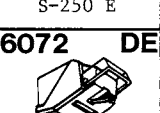
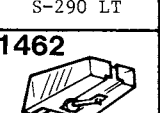
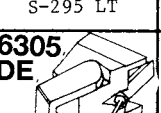
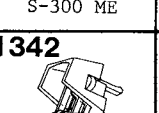

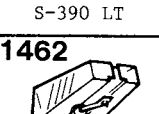
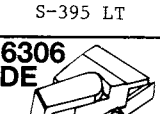
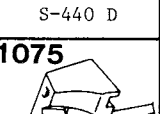
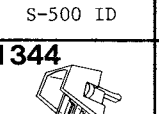
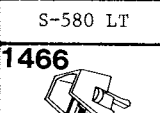
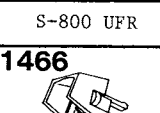
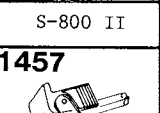
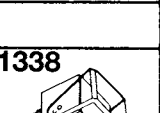
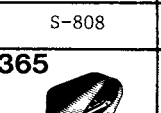
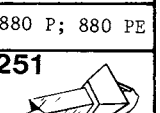
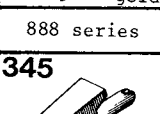
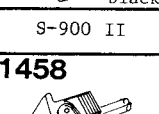
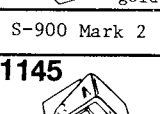
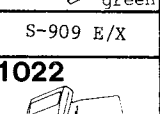
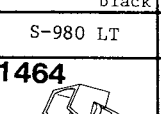
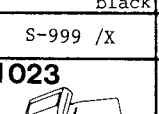
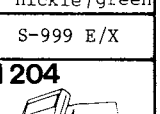
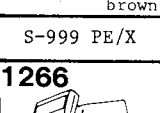
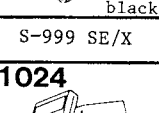
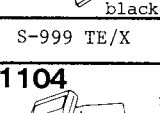
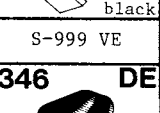
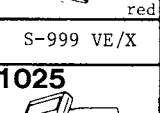
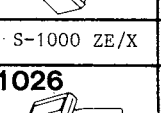
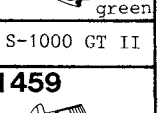
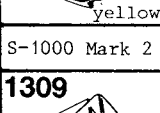
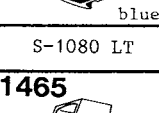
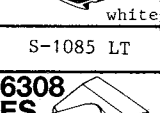
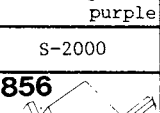
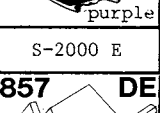
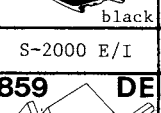
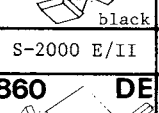
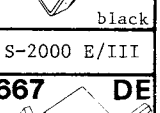
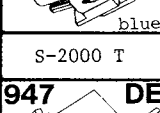
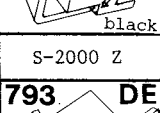
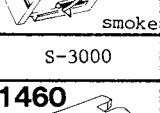
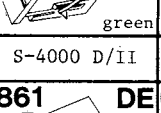
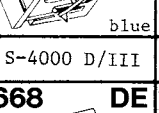
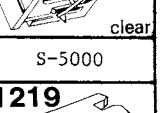

Tonar replacement types for: **E.M.I.**

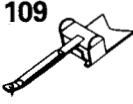
MULTIPLAY 106 	RS 3 107 						
--	---	--	--	--	--	--	--

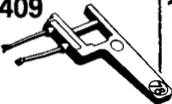

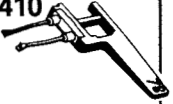

Tonar replacement types for: **EMPIRE SCIENTIFIC (AUDIO EMPIRE)**

SBC-1 1346  yellow	SC-1 6072  black	SE-1 6072 DE  black	S-3 D 6297  l. grey	EDR-7 1460  black	EDR-9 1219  black	EXL-10 1208  red	10 PK 1721  black
10 PE 1722  black	15-C 6311  black	MC +20 1463  gold	25 E 6312 DE  DE	S-40 6298  blue	S-45 E 6299 DE  yellow	66/X 626  red	66 E/X 627 DE  black
66 QE/X 1072  purple	80 EE 365 DE  black	88 249  black	90 EE/X 1021  orange	100 S 968  tr. yellow	SBC-100 1723  black	S-105 6300 DE  black	108; 108 P 250  white
S-111 6221  tr. clear	140 C 6302  blue	150 C 6072  black	150 KC 6313  black	190 LT 1461  clear	195 LT 6304  tr. yellow	200 E 968 DE  tr. blue	SBC-200 1717  clear
S-205 6301  IM white	S-245 E 6303 DE  yellow	S-250 E 6072 DE  black	S-250 KE 6314 DE  DE	S-290 LT 1462  blue	S-295 LT 6305 DE  tr. blue	S-300 ME 1342  tr. brown	S-300 ELT 6309 DE  red
S-333 6222  tr. blue	S-390 LT 1462  blue	S-395 LT 6306 DE  DE smoke	S-400 TC 1343  tr. red	S-440 D 1075  blue	S-485 LT 6307 DE  tr. red	S-500 ID 1344  tr. purple	S-500 PEX 6310 DE  red
S-580 LT 1466  gold	S-600 LAC 1345  black	S-800 UFR 1466  gold	S-800 II 1457  black	S-909 E/X 1338  green	S-808 365  black	S-808 E 365 DE  black	880 P; 880 PE 251  nickle/green
888 series 345  brown	S-900 II 1458  black	S-900 Mark 2 1145  black	S-900 GT 1464  black	S-999 VE/X 1022  red	S-980 LT 1464  black	S-999 /X 1023  brown	S-999 E/X 1204  green
S-999 PE/X 1266  yellow	S-999 SE/X 1024  blue	S-999 TE/X 1104  white	S-999 VE 346 DE  purple	S-1000 ZE/X 1025  purple	S-1000 LT 1026  black	S-1000 GT 1465  black	S-1000 GT II 1459  black
S-1000 Mark 2 1309  blue	S-1080 LT 1465  black	S-1085 LT 6308 ES  black	S-2000 856  smoke	S-2000 E 857 DE  tr. red	S-2000 E/I 859 DE  green	S-2000 E/II 860 DE  blue	S-2000 E/III 667 DE  clear
S-2000 T 947 DE  silver	S-2000 X 924 DE  met. red	S-2000 Z 793 DE  gold	S-3000 1460  black	S-4000 D/I 858 DE  black	S-4000 D/II 861 DE  yellow	S-4000 D/III 668 DE  white	S-5000 1219  black







Tonar replacement types for: **EUPHONICS**

E-1 108 	U-1; J-13 HC 109 	U-8/9 110 	U-8 RB/U-9 RB 409 	U-10/11 111 	U-10 RB U-11 RB 410 	U-12/13 112 	U-15-2 411 
U-15/16 256 	U-17/19 288 						

















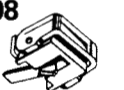

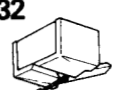

Tonar replacement types for: **EUROFUNK**

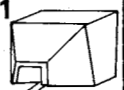
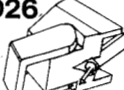
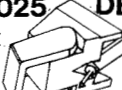
EF-85 756  red	EF-404 756  red	EF-505 792  yellow	EF-606 792 DE  tr. red	EF-707 792 ES  tr. clear			
---	--	---	---	---	--	--	--

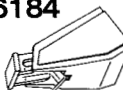



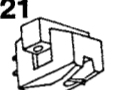

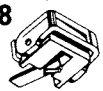

Tonar replacement types for: **EUROPHON**

148 	374  black	524  black	974  yellow	734  black	6191  red	951  white	
---	--	--	---	--	--	--	--





Tonar replacement types for: **EXCEL**

ES-70 E 528 DE  red	ES-70 EX 529 DE  transp. grey	ES-70 EX-4 530 ES  red 4-channel	ES-70 F 527  yellow	ES-70 S 526  blue	ES-70 H 680  red	QD-700 CR 608  blue	QD-700 ER 609 DE  orange
QD-700 XR 610 ES  4-channel yellow	QD-700 FR 670  green	ME-35 632  white	ME-45 809  blue	ME-55 837  red	ME-65 921  clear	ESP-300 C 6026  tr. grey	ESP-300 E 6025 DE  tr. clear
ESP-300 X 6025 ES  tr. purple	S-75 CR ME-75 6184 	S-700 DR ES-700 D 6185 	S-65 XR ME-65 X 6231 ES  tr. purple	S-75 QL 6232 ES  yellow	ES-750 L 6275  yellow	MC-100 E 2521  black	6261  orange



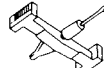
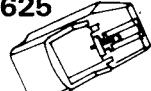

Tonar replacement types for: **EXPERT**

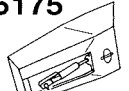
EXPERT		popular	ellipse	disco	quadro	super	78 RPM needle for: DISCO and SUPER
555  green	738  black	555  green	555 DE  black	728  blue	550 ES  white	684 ES  black	736  green
78 RPM needle for: popular ellips and quadro							
737  green							

Tonar replacement types for: **FIDELITY**



			F	T-50 HS			
801 DS  black	625  blue	442  grey	1093  black	6038  grey	6175  red		

Tonar replacement types for: **FIDELITY RESEARCH**

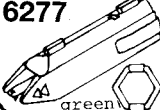

S-5	FR-5 E	FR-101	FR-6 SE				
1365  black	1366  black	1447  black	1467  black				

Tonar replacement types for: **FISHER, See: SANYO**

Tonar replacement types for: **FISHER PRICE**













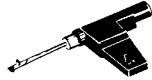

power point	power point						
6277  green	6277  red						

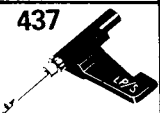
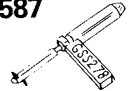
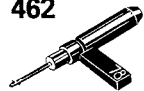
Tonar replacement types for: **FONICA**



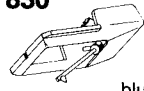
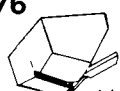
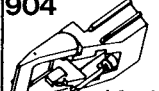

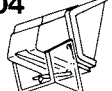

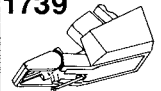
UF-50	UF-70						
299  red	6262  red						

Tonar replacement types for: **FUJIYA AUDIO, See: N.E.C.**

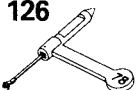
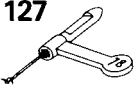
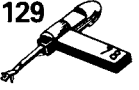

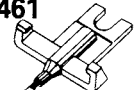
Tonar replacement types for: **GARRARD**

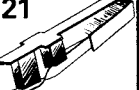
GC-2	GC-8	GC-12	GCM-21 22; GKM-22	GCM-21 T-22 T; GCS-23 T; TS-1; TS-2-3	GCM-31; GSS-1; GCS-35/36	GCS-10	
113 	116 	118 	436 	438 	435 	117 	
GCS-23; GKS-25-26	GCS-38; GSS-2	KS-40 A	KS-41 B	KS-41 C	TOM-1	TOM-2	GMC-50 C
437 	587 	462 	585 	586 	114 	115 	830  blue
ATN-936	GS-22	GS-22 E	GC-11	GA-150	GSN-66 E gradiente		
676  white	904  black	904 DE  black	6004  blue	831  yellow	1739  black		

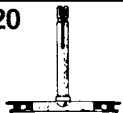
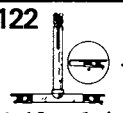
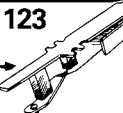
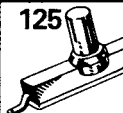
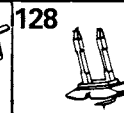
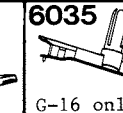



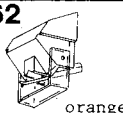
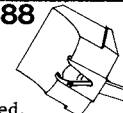

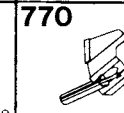



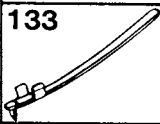
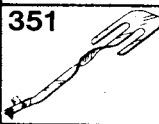
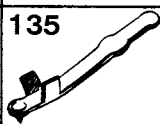
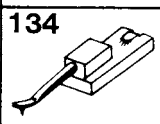
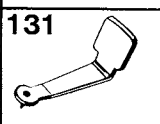
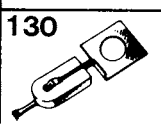
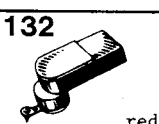
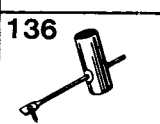
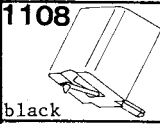
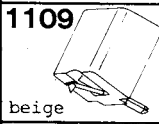

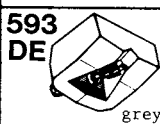

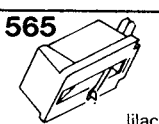
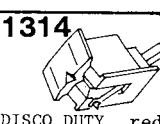
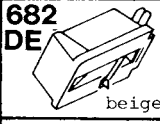
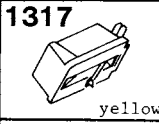
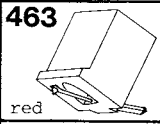
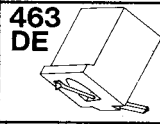
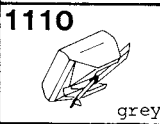

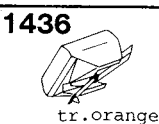
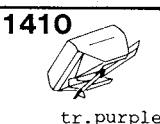
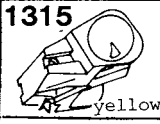
Tonar replacement types for: **GENERAL ELECTRIC**

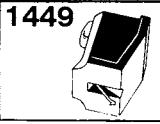
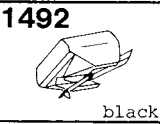
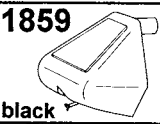
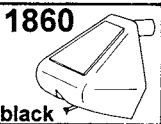
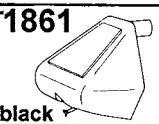
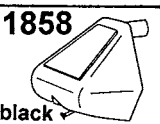
C-100 126 	C-200 127 	C-500 129 	C-650 300 	C-660 461 	GC-7 124 	RPJ-047 121 	RPX-040 119 
RPX-047; 050	VR-II/G-15	VR-II; 4 G	VR-22	VR-1000-7	VR-II/G-16		
120 	122  G-15 only!	123 	125 	128 	6035  G-16 only!		

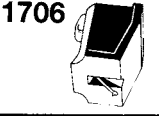
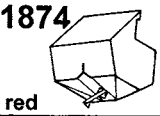
Tonar replacement types for: **GLANZ**

MG-20 R 862  orange	MG-30 R 888  red	MG-50 R 730  white	MG-55 R 711  blue	MG-70 R 770  red			
--	---	---	--	---	--	--	--



Tonar replacement types for: **GOLDRING**

MX 1/2 133 	SX-10 351 	CM-60; CS-80 135 	CS-90; CS-91 E 134 	200 131 	500 130 	580; 600 132  red	700 136 
NG-2 1108  black	NG-2 E 1109  beige	G-800 352  white	G-800 E 594 DE  grey	G-800 Super E 593 DE  grey	G-800 H 476  red	G-820 565  lilac	G-820 DJ 1314  DISCO DUTY red
G-820 E 682 DE  beige	G-820 SE 1317  yellow	G-850 463  red	G-850 E 463 DE  red	G-900 SE 1110  grey	G-900 IGC 1316  tr. green	G-910 IGC 1436  tr. orange	G-920 IGC 1410  tr. purple
G-950 1315  yellow	G-950 E 1429  grey	EPIC 1449  black	G-900 SE MK II 1492  black	1010; 1012GX 1859  black	1020; 1022GX 1860  black	1040; 1042 1861  black	1006 1858  black
G-900 SR 1699  tr. green	EPIC DJ-E 1706  black	ELECTRA 1874  red	2100 6816  black	2200 6820  black	2300 6822  black	2400 6824  black	2500 6826  black

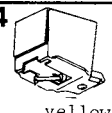
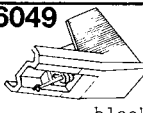
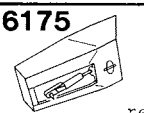
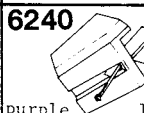
Tonar replacement types for: **GOLDSTAR**

974  yellow	6049  black	6175  red	6240  purple IM				
---	---	---	---	--	--	--	--





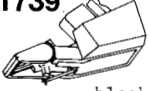

Tonar replacement types for: GRACE

F-8; F-21	F-9 L						
502  clear	1636  clear						

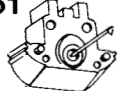
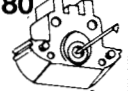
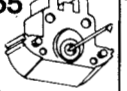

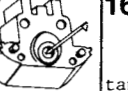

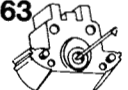
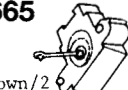

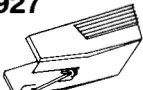

Tonar replacement types for: GRADIËNTE

GSN-66 EMC							
1739  black							

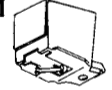
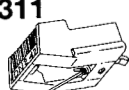

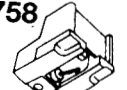

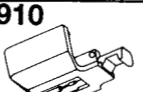
Tonar replacement types for: GRADO

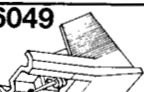
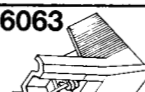
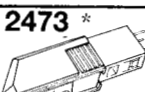
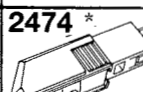
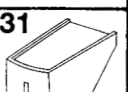
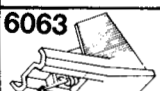
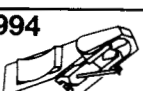
B-SERIES	F-SERIES	FE-SERIES	MTE +/S	MTE +1/S	MF 3E +/S	MF 2 +/S	MF 1 +/S
468  grey	551 	1180  tan	1655  tan/2 red dots	1656  tan/2 silv.dots	1657 	1659  tan/2 white dots	1661  tan/2 blue dots
M +/S	M 1 +/S	M 2 +/S	GTE +/S	black; green			
1663  brown	1665  brown/2 yellow dots	1667  brown/2 gold dots	1669  78 r.p.m.	551 DE			

Tonar replacement types for: GRUNDIG

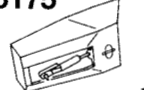
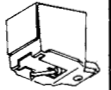
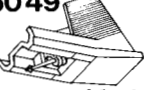
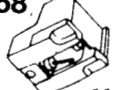
P-24	ATN-102	ATN-102 EP	DN-235	DN-236	GP-500 MK II		
940  tr.orange	927  grey	986 DE  green	981  white	1311  black	534  black	758  yellow	768 DE  green
		DN-239		MG-44 J	MMD-340	MMD-345	P-30 S
832  red	910  red	981  white	6049  black	6063 	2473 * 	2474 * 	6031 
MG-45	GP-330						
6063 	994 						



Tonar replacement types for: HAITAI

					ATN-3651 F	3609 GY	
6175  red	974  yellow	6049  black	758  yellow	6164  orange	6166  yellow	6237  grey	

Tonar replacement types for: **HANDIC**

V-307							
769  blue							











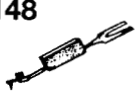

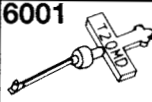
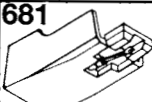
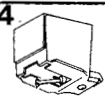



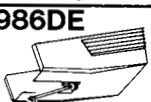
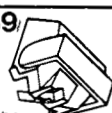
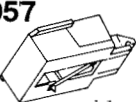
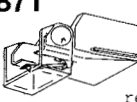
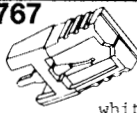
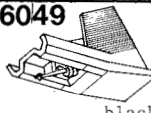
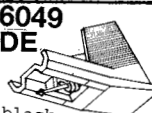
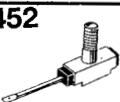

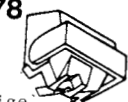



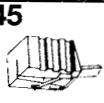
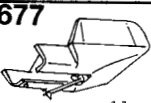

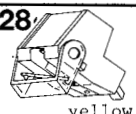
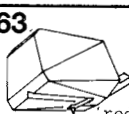
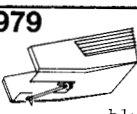
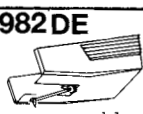
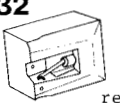

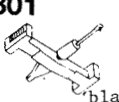

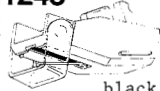
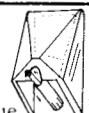
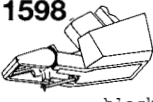
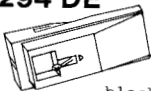
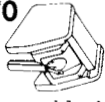
Tonar replacement types for: **HAPE**

MD-4							
725  red	444  white						

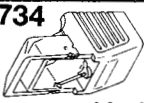

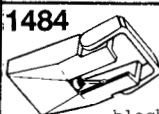
Tonar replacement types for: **HENFAI**

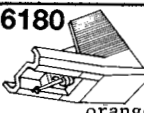
372 							
---	--	--	--	--	--	--	--

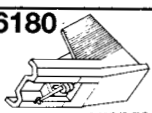
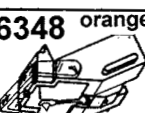
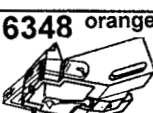



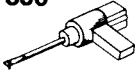

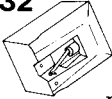
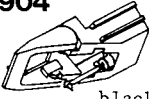

Tonar replacement types for: **HITACHI**

DS-ST-2 148 	DS-ST-3 MFS-170/171 296  white	DS-ST-5 596  white	HN-ST-6 6001  white	HN-ST-7 681  black	DS-ST-7 974  yellow	DS-ST-9 148 	F-11 MT-11 F 509 ES  white
DS-ST-12 DS-ST-14 581  grey	DS-ST-13 MT-13 986DE  green	DS-ST-15 939  white	DS-ST-16 957  black	DS-ST-17 871  red	SJN-18 767  white	DS-ST-18 R 6049  black	DS-ST-18 6049 DE  black
HN-ST-19 452  nickle	HN-ST-20 CFS-280 426  nickle	HT-20 S 978  beige	DS-ST-20 784  white	DS-ST-20 E	F-22 EX MT-22 723ES  beige	DS-ST-23 770  red	DS-ST-24 MT-24 763  orange
DS-ST-25 645  red	DS-ST-26 677  yellow	DS-ST-26 E 894DE  white	DS-ST-30 828  yellow	DS-ST-32 963  red	DS-ST-33 979  blue	DS-ST-33 E 982 DE  black	DS-ST-35 DS-ST-36 832  red
DS-ST-40 MT-10 601  brown/red	SJN-45 801  black	DS-ST-45 HT-M 45 1468  ivory	E-50 MC MT-50 MC 1243  black	DS-ST-55 MT-55 695  tr. blue	DS-ST-60 1598  black	DS-ST-70 DS-ST-72 294 DE  black	E-100 MT-100 1470  black
DS-ST-101 607  ivory	E-101 MT-101 1469  black	DS-ST-102 711  blue	DS-ST-103 734  black	DS-ST-104 748 DE  blue	DS-ST-110 1093  black	E-150 MT-150 1484  black	DS-ST-202 MK2 E-202 MK 2 1472  black
RT-8500 6180  orange	674  green	6279  orange	6180  orange	6348 orange 	6348 orange 		

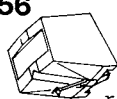
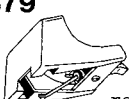
Tonar replacement types for: H.M.V.

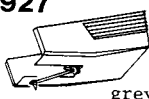
HMV-1	HMV-2						
390 	391  long arm, double tip						

Tonar replacement types for: INKEL

PD-40	PD-607	JB-2000	JB-4000 JB-5000	ATN-3710		ATN-102 P	ATN-122 EP
832  red	904  black	865  orange	956  red	879  red	895  brown	927  grey	6109 DE  brown
ATN-3482 P	PD-608						
6126  yellow	917  red						



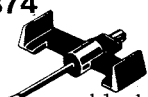





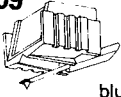
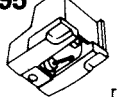
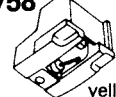

Tonar replacement types for: INTEL

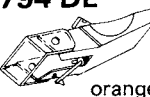
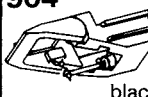
374  black							
--	--	--	--	--	--	--	--











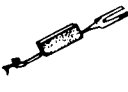
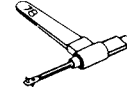
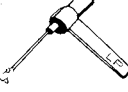

















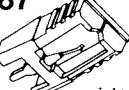
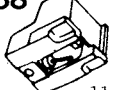

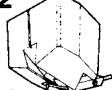









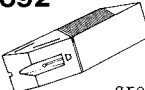
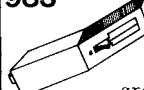

Tonar replacement types for: ISKRA

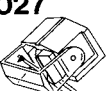
180 							
---	--	--	--	--	--	--	--

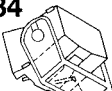
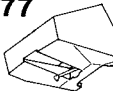
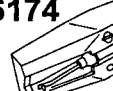
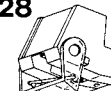
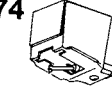

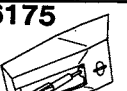
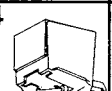

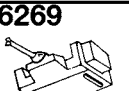
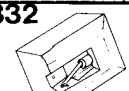





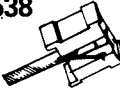

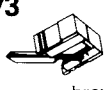
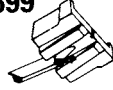
Tonar replacement types for: I.T.T. - GRAETZ

ME-45-77	AT-70	AT-71	AT-12 XE	AT-13 E	ATN-50		ST-30
809  blue	795  red	758  yellow	781 DE  l.brown	794 DE  orange	904  black	832  red	6016  blue
			AP-591	ST-40			
673  red	6239  blue	6259  red	6208  purple	917  red			



Tonar replacement types for: **JAPAN COLUMBIA (DENON)**

DSN-1;SJM-1 148 	JTS-1/5; DTS 1/5 349 	JTS-3 272 	DSN-3 6073  nickle	DTS-4 6074  nickle	DSN-4 6075  nickle	DSN-5 6076  nickle	DSN-6 6077  white
DSN-7 DSN-8 6078  white	DSN-9 6192  white	DSN-10;DSN-13 296  white	DSN-11 6087  grey	DSN-14 644  red	DSN-16; SJN-16 452  nickle	DSN-22 786  grey	DSN-24; GN-20 499  red
DSN-28 677  yellow	DSN-32 6079  orange	DSN-34 705  ivory	DSN-35 371  white	SJN-18 DSN-38 767  white	DSN-39 758  yellow	DSN-40 6080  white	DSN-41 772  tr. black
DSN-42 892  black	DSN-44 823  black	SJN-45 DSN-45 801  black	DSN-46 6351  white	DSN-47 937  orange	DSN-48 938  tr. orange	DSN-50 834  orange	DSN-51 949  orange
DSN-54 741DE  green	DSN-55 475  orange	DSN-57 980  red	DSN-60 931  white	DSN-61 692  grey	DSN-62 983  grey	DSN-63 957  black	DSN-85 6910  white
DSN-65 6027  brown	DSN-66 6016  blue	DSN-67 6233  blue	DSN-68 6084  red	DSN-69 877  orange	DSN-70; SJN-68 6174  red	DSN-71 828  yellow	DSN-72 974  yellow
DSN-73 885 DE  tr. clear	SJN-75 6175  red	JN-78 K 974  yellow	DSN-80 DL-80 A 1672  red	DSN-25 6269  orange	ATN-3400 832  red	DSN-36 6349  white	DSN-81 6353  grey

Tonar replacement types for: **JELCO**

MCI-5 538  grey	SMC-101 533  grey	MC-9 573  brown	MC-12 699  red	MC-14 637  red	MC-15 700  green	4C-1X 701  yellow 4-channel	D 637  red
MC-45 D 952  red	D 908  black	MC-29 6255  red	MC-12 6268  black	TC-812 E 792 DE  red	MC-50 D 6274  black		

Tonar replacement types for: **JENSEN**

409C; 64-1	J-2T		B-2735				
276 	343 		42 				







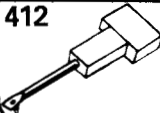









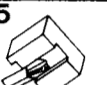

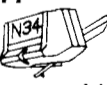
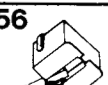











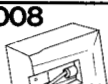



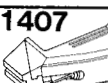
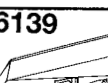
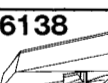

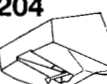
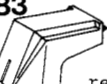
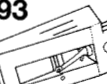
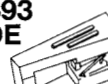
Tonar replacement types for: **J.V.C., See: NIVICO**

Tonar replacement types for: **JUKEBOXES, See: N.S.M., Schuman, Seeburg, Zenith types**

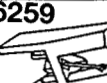
Tonar replacement types for: **K.D.**

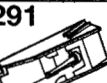
69							
412 							

Tonar replacement types for: **KENWOOD**

N-6 AT	N-11	N-15 O MK II	NF-15 O MK II	N-20	N-23	N-25	N-26
296  white	758  yellow	803  white	802  red	780  white	445  grey	654  l. grey	771  black
N-30	N-31	N-32; N-33	N-34	N-35	N-36	N-37	N-38
654  l. grey	655  black	571  white	541  white	686  brown/silver	656  dark grey	657  red	325  scarlet
N-39	N-39 MK II	N-39 MK III	N-40	N-41	N-42	N-43	N-44
326  orange	958  black	829  black	323 ES  4-channel	677  yellow	323 ES  4-channel	658  blue	688 ES  4-channel
N-45	N-46	N-47	N-48	N-49	N-50	N-51 E	N-52
1493  MC	755  black	730  white	758  yellow	764  orange	908  black	908 DE  black	6008  blue
N-53/V-53	N-54	N-55	N-56; N-56 B	N-57	N-58	N-59	N-77
876  black	6021  blue	1408  MC blue	935  black	1407  green/black	6139  IM black	6138  MM dark grey	6353  grey
N-61	N-62; V-62	N-63	N-64	N-64 C	N-65	N-66	N-67
6204  MM blue	6183  red blue	6158  blue	393  black	393 DE  black	6249  green	6257  MM red	6258  MM red
N-68	N-69	N-70	N-71	N-72	N-73	N-74	N-75
6283  blue	6259  MM red	1586  grey	6291  black	6335  blue	6204  MM purple/blue	6334  black	957  black







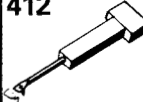



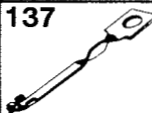

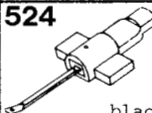
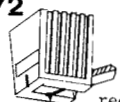
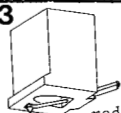
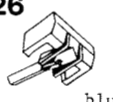
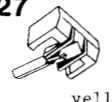
Tonar replacement types for: K.L.H.

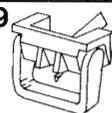
832  red							
--	--	--	--	--	--	--	--









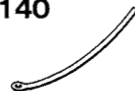
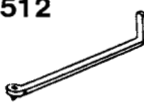

Tonar replacement types for: K.S.M.U.

0261 448 	KD-69 412 						
---	--	--	--	--	--	--	--

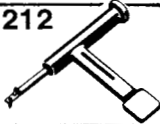
Tonar replacement types for: Lenco

single 137 	double 138 	RCS Pop Stereo 524  black	M-94 672  red	M-95 463  red	M-100 526  blue	M-100 527  yellow	M-150 565  purple
M-200 309  red	M-300 1599  black	M-350 1599  black	OMB-20 1253  black	GS-11 1835  black	M-400; M-550 6259  red	L-3807 USB 6259  red	L-3866 USB 6259  red

Tonar replacement types for: LESA

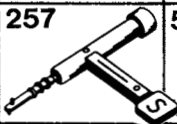
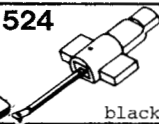
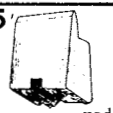
A 139 	B 140 	C-1 512 	D 137 	E 141 	F-3 344 	F-5 310 	K-2 212 
K-3 592 	K-3 New Version 368  black	S 144 	U 142 	U-2 143 	W 257 	524  black	725  red

Tonar replacement types for: **LESON**

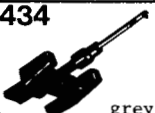
LESON							
434  grey							

Tonar replacement types for: **LIN SONDEK**

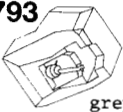
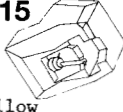
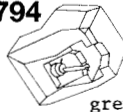

K-5	K-9 4-channel	K-18 4-channel					
1793  grey	1715  yellow	1794  grey					

Tonar replacement types for: **L.O.D., See: HITACHI**







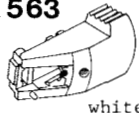
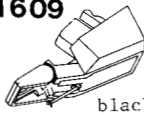
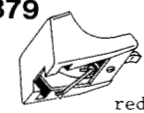
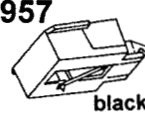
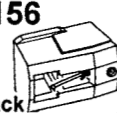

Tonar replacement types for: **LUSTRE**

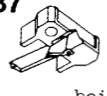
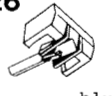
L-1							
457 							

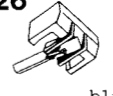



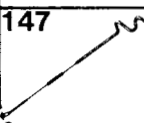







Tonar replacement types for: **LUXMAN**

	ATS-11	ATN-71 E	N-310 C	N-320 C	ATN-3710		
974  yellow	677  yellow	768 DE  green	1563  white	1609  black	879  red	957  black	6156  black

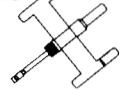
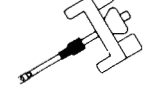
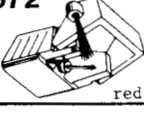

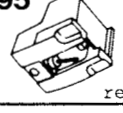
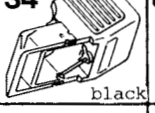
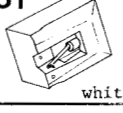

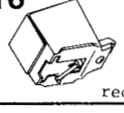
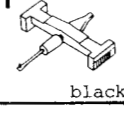
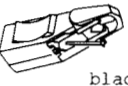
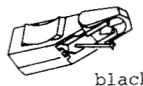
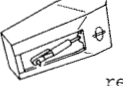
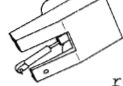





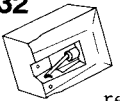

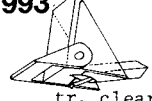
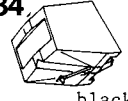
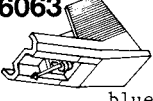
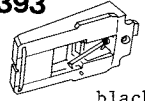

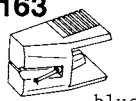
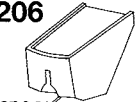
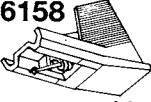
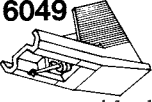
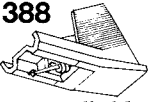

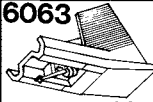
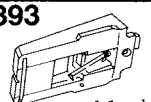
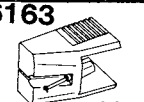
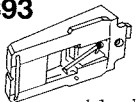
Tonar replacement types for: **LUXOR**

3200	3823	3831; 3833	8000	36200	65977	72411	72786
465  grey	387  beige	526  blue	802  red	526  blue	148 	145 	146 
74916							
147 	758  yellow						

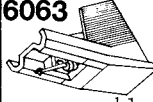
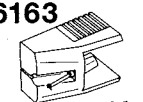
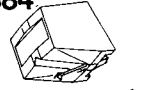
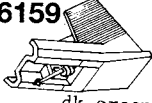
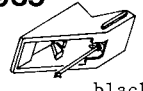
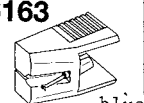

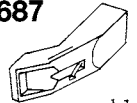
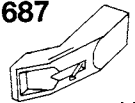

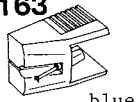
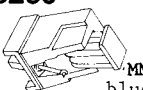
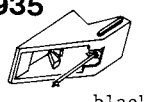
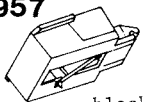
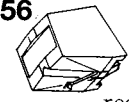
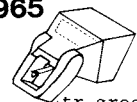

Tonar replacement types for: **MAGNAVOX**

560101	560151/560133	560161	560247	560305	560344/45	560347-1	560348
150 	149 	151 	200 	277 	303 	525 	317 
560398	560356	560369	560418	560429	560434	25130071	5604370033
572  red	571  white	795  red	734  black	851  white	910  white	916  red	801  black
25130079	25130081		5690300003	5604370111			
994  black	994 DE  black	6175  red	6172  red	6111  white			

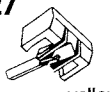

Tonar replacement types for: **MARANTZ**

CT-5 S 832  red	CT-6 S 922 DE  green	CT-100 993  tr. clear	TT-130 TT-221 384  black	TT-140 6063  blue	TT-143 393  black	TT-151 981  white	TT-151 6163  blue
TT-153 6206  orange	CT-165 6158  blue	TT-170 6049  black	TT-185 CTS-165 388  dk. blue	TT-221 384  black	TT-240 6063  blue	TT-243 393  black	TT-251 6163  blue
TT-253 393  black	TT-275 6234  IM red	TT-285 957  black	CT-300 TT-320 384  black	TT-333 935  black	CT-340; TT-340 TT-440 6063  blue	TT-351 6163  blue	CTS-420 384  black
TT-430 6159  dk. green	TT-433 TT-443 935  black	TT-451 6163  blue	500 758  yellow	CS-500 973  white	TT-520 687  blue	TT-525 687  blue	TT-530 6026  grey
TT-551 6163  blue	CT-551 6260  MM blue	TT-553 935  black	TT-873 957  black	956  red	965  tr. green	6354  black MM	





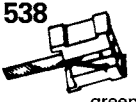

Tonar replacement types for: **MARLUX**

NM-106 661  grey	MC-500 666  green	NM-33 296  white	527  yellow	789  red	SX-50S 792  tr. yellow	MX-66 1108  black	
---	--	---	---	--	---	--	--

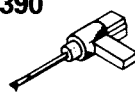
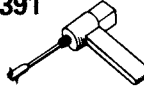
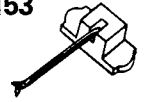

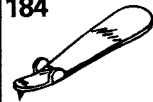
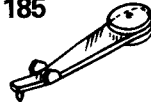

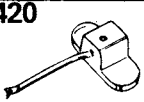

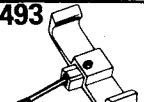
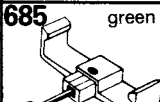
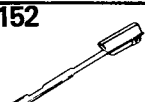
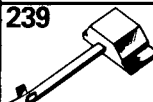
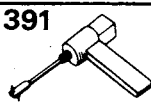





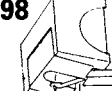

Tonar replacement types for: **MASTERCRAFT**

MCI-5 538  green	SJN-1 270 	SMC-101 533  grey					
---	--	--	--	--	--	--	--

Tonar replacement types for: **MERULA**





FANFARE 182 	HMV-1 390 	HMV-2 391 	SC-474 153 	SK 451 183 	SK 452 184 	SK 453 185 	SK 456; STK 494 186 
STC-480 420 	STC-485/486 414  Jupimatic	STC-487 493  black	STC-488 685  green	STK-490 152 	STK-495/1 239 	STC-481 391 	

Tonar replacement types for: MICRO

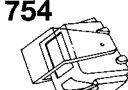
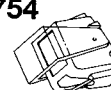
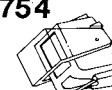

SC-301	M-207	V-2100	V-3100	V-3200	V-3300/7	V-307; V-7000	VP-1; V-8; V-10; V-70
359  new yorker	399  white	598  red	400  grey	636  red	735  black	769  turquoise	775  black
V-5	V-20	V-40	V-7; LF-7	V-307 IM type	V-3200 E V-3200 XE	V-1100 V-1110	
776  blue	777  black	852  black	918 DE  black	6013  IM beige	636 DE  red		

Tonar replacement types for: MICRO ACOUSTICS















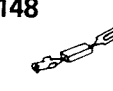
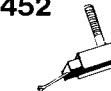

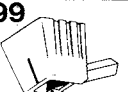

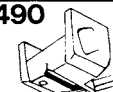



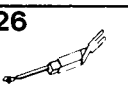

(STYLI AVAILABILITY IS ERRATIC)

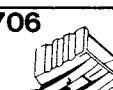
QDC-1E; QDC-1S 282 E; 530 MP	MA-282 E	QDC-1E; QDC-1S	309; 382; 3002 630; 830 CSA	50-PE (T4P)	100 E	2002 E	
1754  black	1754  black	1754  black	no longer available 	6310  red	no longer available 	1754  black	

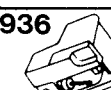
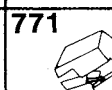
Tonar replacement types for: MISSION

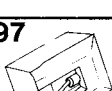
773 MM	774	SOLITAIRE					
637  red		6268  black					

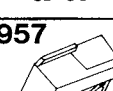
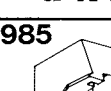
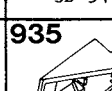
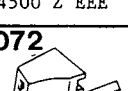
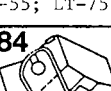
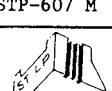
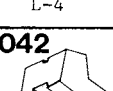
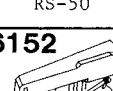
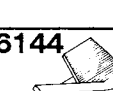
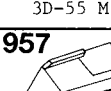
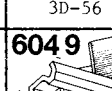
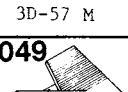

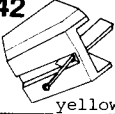

Tonar replacement types for: MITSUBISHI

MD-1	3D-MM 1	MD-2	3D-MM2	STYLUS 5 LMT-5	3D-20 M; ST-15; SP-16	SJN-16	SJN-18
649 DE  beige	6121  black	649  brown	1276  black	1319  black	148 	452 	767  white
3D-23 M	3D-24 M	3D-25 M	3D-26 M	3D-28 M	3D-29 M	3D-30 M	3D-31 M
399  white	399  white	566  white	1490  white	400  ivory	6088  white	647  green	646  green
ST-11; 3D-32 M	3D-33 M	3D-34 M	3D-37 M	3D-38 M	3D-40 M	3D-42 M	3D-44 M
426 	582  green	674  green	649  brown	706  green	571  ivory	936  black	771  black
3D-45 M	3D-46 M	3D-47 M	3D-48 M	3D-50 M	3D-51 M	3D-52 M	3D-54 M
936  black	6009  brown	897  brown	822  white	913  black	957  black	985  blue	935  black
4500 Z EEE	LT-55; LT-75	STP-607 M	L-4	RS-50		3D-55 M	3D-56 M
1072  purple	6084  red	 red	6042  blue	6152  black	6144  smoke grey	957  black	6049  black
3D-57 M							
6049  black	981  white						





Tonar replacement types for: **MULTITECH**

M-22							
6242  yellow							





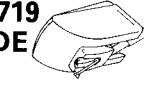













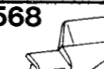

Tonar replacement types for: **N.A.D.**

NAD 9100	NAD-9200	NAD-9300	TT-533	520			
1231  grey	1231  grey	1391  grey	1874  red	1834  red			

Tonar replacement types for: **NAGAOKA**

JT-311	JT-322	NC 100; 202; 203 NC 505; 400; 400H	NC 202; 203; 400 NC 400 H	NC-700	NC-770	NM-11 A	NM-22
555  green	550 ES  4-channel white	27  grey	148  stereo	494  grey	270  red	222  black	263  white
NM-33	NM-33-A	NM-66	NR-1	JT-333	JT-511	JT-555	JT-511 BE
296  white	453  blue	447 DE  grey	363  black	683 ES  red	664  red	684 ES  black	746 DE  yellow
JT-511 DJ	78 RPM needle for: JT-511 series; JT-555	78 RPM needle for: JT-311; JT-322	OS-100 MP	OS-200 MP	OS-300 MP	C-711-01	MP-100 ; MP-10
728  blue	736  green	737  green	717  transparent clear	719 DE  transparent grey	721 DE  solid black cantilever transparent purple	808  green	6819  red
MP-110 ; MP-11	MP-150 ; MP-15	MP-200 ; MP-20	MP-300 ; MP-30	MP-500 ; MP-50	C-320 M	MM-321 B	C-711
6821  yellow	6823  green	6825  purple	6827  white	6829  black	914  all pl. tr. green	945  tr. green	808  MM green
C-721	MP-05	MP-50 Super	JN-110 JT-110	JN-120 JT-120	JN-11 EB MP-11 EB		
943  IM green	944  purple	1250  black	6003 ES  black	6151  black	1601  black		
NMP-1.0 MIL	NMP-2.0 MIL	NMP-2.5 MIL	NMP-3.0 MIL	NMP-3.5 MIL	NMP-4.0 MIL		
6837  MONO	6839  78 RPM	6845  78 RPM	6835  78 RPM	6841  78 RPM	6843  78 RPM		











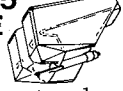









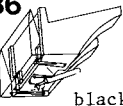
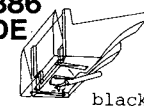















Tonar replacement types for: **NATIONAL (PANASONIC, TECHNICS)**

EPS-02 C-103 6123 	EPS-04 LP EPC-27 WTGS 5 148 	EPS-04 ST EPC-29 TTGS 1 148 	EPS-04 ST EPC-29 TTBS 4 148 	EPS-04 ST EPC-69 STA;STC 148 	EPS-04 STSD EPC-29 TTBS 5 148 	EPS-05 EPC-05; EPC-08 269  nickle	EPS-05 ST EPC-01 TTC 269  nickle
EPS-05 ST EPC-30 TTA 269  nickle	EPS-08 397  black	EPS-10 EPC-83 SMAD 397  black	EPS-10 STDD EPC-83 SMED 397  black	EPS-11 EPC-81 STSD EPC-95 SSAD 648  nickle	EPS-11 STSD EPC-81 STBD 648  nickle	EPS-12 397  black	EPS-13 EPC-34 TTAD 372  black
EPS-13 TT EPC-35 TTA 372  black	EPS-13 TTSD EPC-35 TTAD 372  black	EPS-14 ST EPC-34 STC 374  black	EPS-14 STSD EPC-34 STCD 374  black	EPS-14 STSD EPC-34 STBD 374  black	EPS-18 ST EPC-34 STFA 618  white	EPS-18 STSD EPC-34 STFAD 618  white	EPS-19 EPC-40 STBD 606  black
EPS-19 STSD EPC-40 TTB 402  black	EPS-22 CS-1025 426  nickle	EPS-22 ES EPC-P 22 S 885 DE  tr.clear	EPS-22 ES EPCP 202 CBK 885 DE  tr.clear	EPS-23 CS EPC-P 23 S;SK 885  tr.clear	EPS-23 CS; ES EPC- P 23 885  tr.clear	EPS-24 CS EPC- P 24 940  tr.orange	EPS-24 STSD EPC-95 SSED 451  nickle
EPS-25 EPC-42 516  grey	EPS-25 CS EPC-U 25 S;SK 6023  tr.brown	EPS-25 CS U-25; H-25 6023  tr.brown	EPS-25 STSD EPC-42 STAD 516  grey	EPS-27 EPC-09 STAD 842  white	EPS-27 CS EPC-P 27 959  tr.yellow	EPS-28 EPC-96 SS 600  yellow	EPS-28 CS EPC-P 28 959  tr.yellow
EPS-30 STSD EPC-82 SMAD 677  yellow	EPS-30 CS EPC-P 30 6031  blue	EPS-31 SPSD 741  green	EPS-31 STSD EPC-82 SMBD 571  white	EPS-33 ES EPC-P 33 6032  grey	EPS-34 STSD EPC-78 SMAD 748 DE  blue	EPS-35 STED 748 DE  blue	EPS-35 STSD EPC-78 SMBD 568  red
EPS-36 STSD EPC-05 STA 629  white	EPS-37 EPC-37 376  white	EPS-39 STSD 850  white	EPS-41 STSD EPC-41; EPC-13 951  white	EPS-43 STSD 991  grey	EPS-45 STQD EPC-450 C 630 ES  4-channel grey	EPS-46 STSD EPC-460 C 650  yellow	EPS-46 STQD EPC-460 C 4 621 ES  4-channel grey
EPS-50 EPC-84 SM 759 DE  black	EPS-51 EPC-85 SM 759 DE  black	EPS-51 CS EPC-P 51 S 6117  red	EPS-52 EPC-86 SNAD 599  orange	EPS-53 EPC-87 SMAD 6119 DE  tr.clear	EPS-P 53 CS EPC-P 53 S 6118  tr. red	EPS-54 EPC-88 SMAD 759 DE  black	EPS-56 EPC-79 SMAD 749  blue
EPS-74 STED EPC-74 SMED 760 DE  blue	EPS-74 STSD EPC-74 SMAD 758  yellow	EPS-75 SMLD 6064  orange	EPS-75 STSD EPC-75 SMAD 832  red	EPS-75 STCSD EPC-75 851  grey	EPS-75 STHSD 991  dark grey	EPS-75 TFSD 898  yellow	EPS-76 STED 851  grey
EPS-76 STSD 831  yellow	EPS-90 SMAD 986 DE  green	EPS-90 SMBD 927  grey	EPS-90 STGD 927  grey	EPS-90 STGED 986 DE  green	EPS-91 SMAD 581  white	EPS-100 ED 2 1369  black	EPS-100 ED 4 EPC-100 C MK 4 1501  black



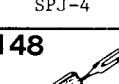
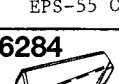

CONTINUED

Tonar replacement types for: NATIONAL (PANASONIC, TECHNICS)



CONTINUED

EPS-P 100 ED 4 EPC-P 100CMK4 1502  tr.clear	EPS-202 ED EPC-P 202 C 885 DE  tr.clear	EPS-205 ED EPC-205 C II S 759 DE  black	EPS-205 ED EPC-205 C2 LKX 766 DE  gold	EPS-205 ED EPC-205 C2 SKX 766 DE  gold	EPS-205 EX EPC-205 C II 766 DE  gold	EPS-205 ED 3 EPC-205 C MK 3 766 DE  gold	EPS-205 ED 4 EPC-205 C MK 4 1503  gold
EPS-P205 ED 3 EPC-P205 C MK3 1504  tr.clear	EPS-P205 ED 3 EPC-P205 C3K 1504  tr.clear	EPS-P205 ED 4 EPC-P205 C MK4 1504  tr.clear	EPS-206 C 886  black	EPS-206 ED EPC-206 CK 886 DE  black	EPS-207 C 841  black	EPS-207 ED EPC-207 C 841 DE  black	EPS-207 ED EPC-207 C II 841 DE  black
EPS-207 ED EPC-207 CK 841 DE  black	EPS-270 SD EPC-270 CK;CX; EPC-270 CKX;CZX 757  tr.green	EPS-270 SD EPC-270 C; D 757  tr.green	EPS-270 ED EPC-270 C II 757 DE  tr.green	EPS-270 ED EPC-270 C2K-X 757 DE  tr.green	EPS-270 ED EPC-271 C 757 DE  tr.green	EPS-270 ED EPC-271 CES 757 DE  tr.green	EPS-270 ED EPC-271 CS-X 757 DE  tr.green
EPS-275 EPC-09 STAD 842  white	EPS-290 SD EPC-290 C 599  tr.orange	EPS-310 MC EPC-310 MC 1521 No longer available	EPS-310 MC 2 EPC-P 310 MC 2 2237 No longer available	EPS-405 QD EPC-405 C 759 ES  4-channel, black	EPS-440 QD EPC-440 C 599 ES  4-channel clear	EPS-450 QD EPC-450 C II 1544  clear 4-channel	EPS-451 QD EPC-451 C 628 ES  4-channel red
EPS-510 CS EPC-P 510 S 6031  green	EPS-520 ES EPC-P 520 6031 DE  blue	EPS-530 ES EPC-P 530 6340 DE  grey	EPS-540 ES EPC-P 540 6341 DE  gold/black	EPS-550 ES EPC-P 550 6342 DE  red gold		EPS-24 ES EPC-P 24 940 DE  tr. orange	
P-30 S 6031  blue	EPC-P 328	EPC-P 511 S	EPC-01 WTB	SPJ-4	EPS-55 CS	P-34; EPS-34CS	EPS-1200 CS
				148 	6284  tr. green	6049  black	6855 (DJ)



Tonar replacement types for: NEAT

N-100 148 	VS-700; V-70; VS-90 389 	VS-80 526 	533  grey				
--	---	--	---	--	--	--	--





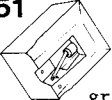
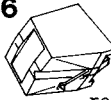
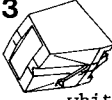

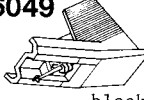
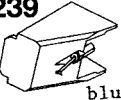





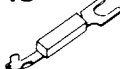







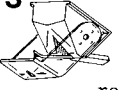
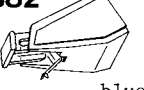
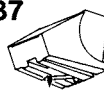

Tonar replacement types for: **NEUFUNK**

368 	293 						
---	---	--	--	--	--	--	--

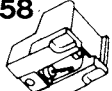



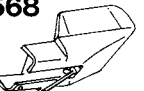
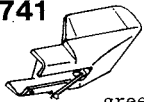

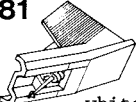
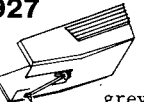
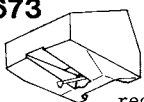
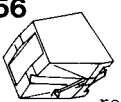
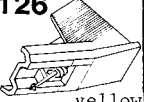
Tonar replacement types for: **NIKKO**

851  grey	956  red	973  white	801  black	6049  black	6239  blue		
---	--	--	--	---	---	--	--

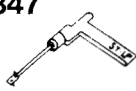



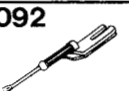

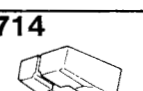
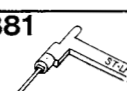
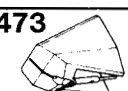
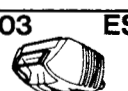
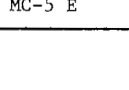
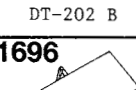
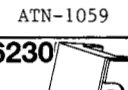
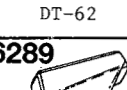
Tonar replacement types for: **NIPPON ELECTRIC COMPANY (N.E.C.)**

LP-5 D; SP-5 S	LP-10 D	SP-15 S; LP-15 D	LP-20 D	LP-25 D	LP-30 D	LP-35 D	LP-40 D
269 	397  black	148 	296  white	367  white	786  grey	653  black	456  white
LP-45 D	LP-50 D	LP-55 D	LP-60 D	LP-65 D	LP-70 D	LP-75 D	LP-305 M
641  black	711  blue	578  black	822  white	730  white	834  orange	813  red	382  blue
LP-310 D	LP-335 D LP-355 D	LP-735 D	LP-5100 D	LP-6000 D	LP-6100 D	LP-6300 D	LP-7000 D
937  orange	832  red	758  yellow	651  MM	760  blue	726  green	726  l. brown/green	568  red
LP-8000 D	LP-8300 D	AT-3472 P					
741  green	637  red	581  white	927  grey	673  red	956  red	6126  yellow	

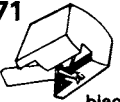
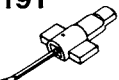
Tonar replacement types for: **NIVICO**

DTS-1 347  white	DTS-2 348  black	DT-7 148  white	DT-11; SS-11 510  white	DT-12 6089  white	DT-13 6090  white	DT-15 6093  nickle	DT-16 296  white
ST-17 348  black	DT-18 6094  white	DT-19 6091  MM white	DT-20 426  nickle	DT-21 6108  IM blue	DT-22 6092  white	DT-23 659  black	DT-25 H 552  IM red
DT-26 639  white	DT-27 596  IM red	DT-29 595  MM red	DT-30 S 853  IM blue	DT-31 571  white	DT-32 660  green	DT-33 G 640  green	DT-33 H 545  yellow
DT-33 S 509  white	DT-34 S DE 720  black	DT-36 813  red	DT-37 MD-1034 906  blue	DT-38 898  yellow	DT-39 E 923  DE black	DT-41 LE-500;LE-600 930  purple	DT-45 388  DE dark blue
DT-45 E 388  DE brown	DT-50 714  orange	DT-51 801  black	DT-55 974  yellow	DT-55 W 6122  orange	DT-55 MK2 987  blue	VPP-96 381  STEP	DT-100 E MC-100 EB 1475  MC ivory
DT-200 E 1606  MC red	DT-201 988  MC blue	DT-201 E 1477  MC blue	DT-Z 1S 718  khaki	DT-Z 1 739  ES tr. clear	DT-Z 1 EB 932  DE tr. green	DT-Z 1L1S 473  blue	DT-E 3E 1602  red
DT-Z 3 ED 884  DE tr. red	DT-Z 4 S 884  red	DT-U 2 1471  naked 4-channel black/ white line	DT-U 2E 1473  naked elliptical black/ red line	DT-X 1 MK I 1287  clear	DT-X 1 MK II 740  ES transparent clear	4 DT-1 X 509  ES white 4-channel	4 DT-2 X 703  ES black 4-channel
4 DT-5 X 509  ES white 4-channel	4 DT-10 X 509  ES white 4-channel	4 DT-20 X 619  ES red 4-channel	4 DT-30 X 620ES  grey 4-channel	4 DT-35 X 620 ES  grey 4-channel	DT-35 6169  brown	DT-56 957  black	DT-57 6111  ivory
DT-58 6050  blue	DT-59 6230  blue	DT-60 6265  orange	DT-Z 5 P Z-5 P 6168  tr. orange	MC-5 E 6166  yellow	DT-55 B 6246  blue	DT-55 II B 6250  DE tr. orange	DT-Z 1 E 6111  ivory
DT-202 B 1696  grey	DT-58 B 6264  l. blue	ATN-1059 6230  green	DT-X 1 MK II 1751  elliptical	DT-X 1 MK II 1752  shibata	DT-62 6289  MM tr. blue	DT-62 6175  red	
DT-64 6111  white	DT-65 981  white						



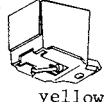

Tonar replacement types for: **NORDMENDE**

ST-10 J					L-4	OMB-10	
771  black	6191  red	904  black	961  grey	917  red	1400  blue	1276  black	974  yellow



Tonar replacement types for: **NOVAK**

CLARVILLE							
72 							

Tonar replacement types for: **N.S.M. / WURLITZER**

N-17 CM		DB-200; D-102	CONSULT 120				
605  blue	6223  black	182  Gold	182  Gold				

Tonar replacement types for: **NUMARK**

CC-1	CS-1	Groovetool					
6813  silver	6815  silver	6259  red					

Tonar replacement types for: **NUWAY**

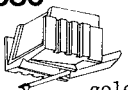
NS-88							
6086  gold							



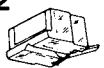











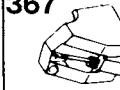



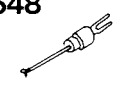
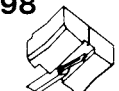



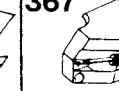



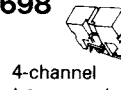

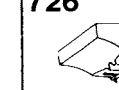
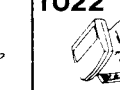
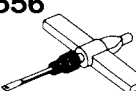

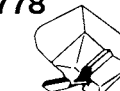

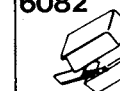

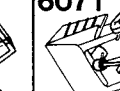
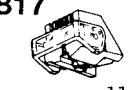

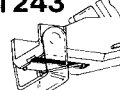



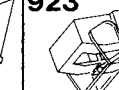
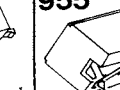





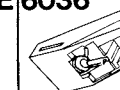





Tonar replacement types for: **OHIO SOUND**

T-8i2 E							
792 DE  tr. red							

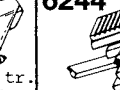

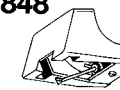



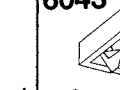



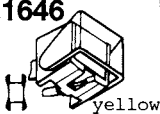
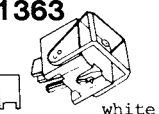
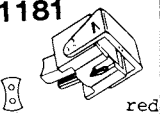
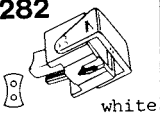
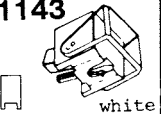

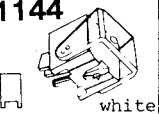
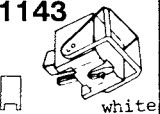

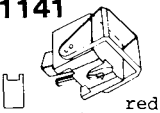

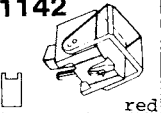
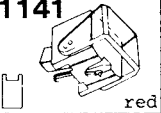
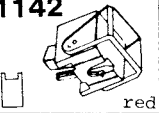
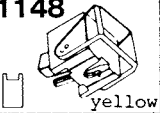
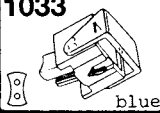
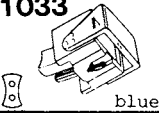
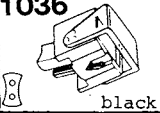
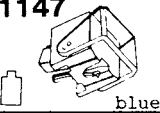
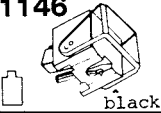

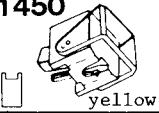

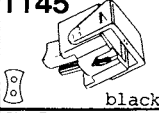
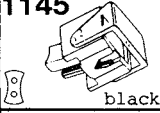
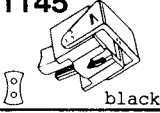
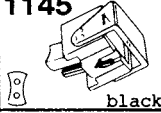
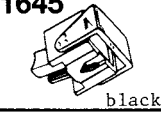
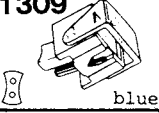
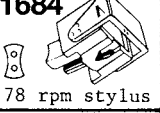
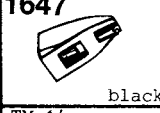
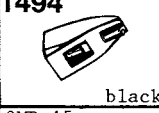
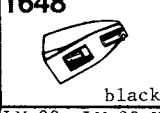
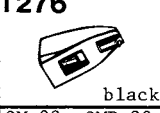

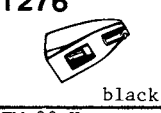
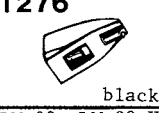
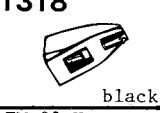



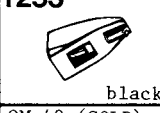

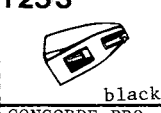

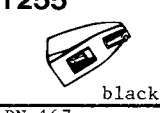
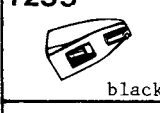
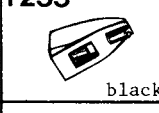
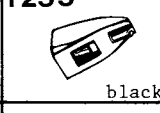
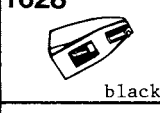



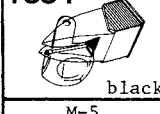
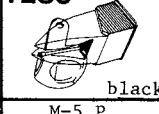
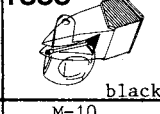
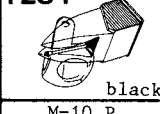
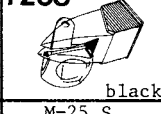

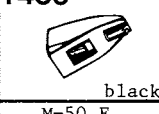

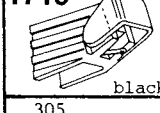
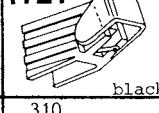
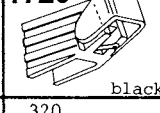
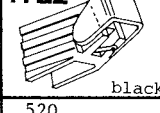
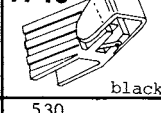
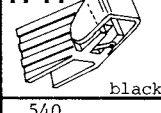
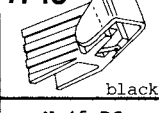
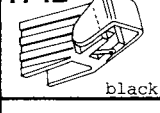



Tonar replacement types for: **OLYMPIC**

1							
378 							

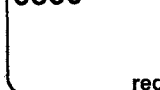
Tonar replacement types for: **ONKYO**

DN-1 ST; SN-2 ST	DN-3 ST	DN-5 ST	DN-7 ST	DN-8 ST	DN-10 ST	DN-12 ST	DN-13 ST
148 	269 	296  white	397  black	367  white	397  black	374  black	296  white
DN-14 ST	DN-15 ST	DN-16 ST	DN-17 ST	DN-18 ST	SN-19 ST	SN-20 ST	DN-21 ST OC-21 M
648  nickle IM	398  grey	B10  white	397  black	499  red	535  brown	367  white	506  white
DN-22 ST OC-22 M	DN-23 ST OC-23 M	DN-24 ST	DN-25 ST	DN-27 ST	DN-28 ST	DN-29 ST	DN-30 ST
507  blue	535  brown	589  orange-brown	698  4-channel transparent red	571  white	726 ES  4-channel yellow	726  green	1022  red
DN-31 ST	DN-32 ST	DN-33 ST	DN-34 ST	DN-35 ST	DN-36 ST	DN-37 ST	DN-38 ST
556 	571  white	778  red	6081  blue	758  yellow	6082  green	894  white	6071  blue
DN-39 ST	DN-40 ST	DN-50 MC	DN-51 ST	DN-52 ST	DN-54 ST	DN-55 ST	DN-56 ST
817  yellow	771  black	1243  black	862  red	832  red	949  orange	923  black	955  grey
DN-57 ST	DN-59 ST	DN-60 STE	DN-61 ST	DN-61 STE	DN-62 ST	DN-63 STE	DN-64 STE
708  grey	923  black	802 DE  red	6048  lilac	6048 DE  l. blue	6036  black	916 DE  black	1576  orange
DN-65 ST	DN-66 ST	DN-67 ST	DN-68 ST	DN-69 ST	DN-70 ST	DN-72 ST	DN-106 ST
6193  blue	6043  red	6084  red	6237  grey	6084  red	6286  grey	6024  tr. blue	6244  white
DN-107 ST	DN-201 ST	DN-202 STE	DN-505 MC	DN-1005 ST	OMP-5 E	OM-20	Q-4
6248  orange	848  blue	848 DE  blue MC	1378  blue MM	651  black/white	1494  black	1253  black	6043  red

Tonar replacement types for: **ORTOFON**

NF-10 E FF-10 E	FF-10 XE MK II NF-10 XE MK II	FF-15 D MK II NF-15 D MK II	F-15 S;F-15 O N-15 S;N-15 O	F-15 S MK II N-15 S MK II	F-15 E;F-15 EO N-15 E;N-15 EO	F-15 E MK II N-15 E MK II	F-15 O MK II N-15 O MK II
1646  yellow	1363  white	1181  red	282  white	1143  white	291 DE  white	1144  white	1143  white
F-15 EO MK II N-15 EO MK II	FF-15 NF-15	FF-15 S MK II NF-15 S MK II	FF-15 E NF-15 E	FF-15 E MK II NF-15 E MK II	FF-15 O MK II NF-15 O MK II	FF-15 EO MK II NF-15 EO MK II	FF-15 XE MK II NF-15 XE MK II
1144  white	1756  white	1141  red	1755  white	1142  red	1141  red	1142  red	1148  yellow
M-15 Super D-15 Super	M-15 E Super D-15 E Super	M-20 E N-20 E; DN-350	M-20 E Super D-20 E Super	M-20 FL Super D-20 FL Super	VMS-3 MK II D-3 MK II	VMS-5 E MK II D-5 E MK II	VMS-10 E MK II D-10 E MK II
1033  blue	1033  blue	1036  black	1147  blue	1146  black	1482  white	1450  yellow	1338  green
VMS-15 XE MK II D-15 XE MK II	VMS-20 S D-20 S	VMS-20 E D-20 E	VMS-20 E MK II D-20 E MK II	VMS-20 EO MK II D-20 E MK II	VMS-20 XE MK II D-20 XE MK II	VMS-30 FL MK II D-30 MK II	NF-15/78 rpm
1744  red	1145  black	1145  black	1145  black	1145  black	1645  black	1309  blue	1684  78 rpm stylus
STYLUS 1 NEW	OM-5E; OMP-5 E Stylus 5 E New	STYLUS 7 NEW	TM-10 H; LM-10 STYLUS 10 NEW	OM-10; OMP-10 STYLUS 10 NEW	CONCORDE 10 STYLUS 10 NEW	CONCORDE EC-10 STYLUS 10 NEW	OMB-12 STYLUS 12 NEW
1647  black	1494  black	1648  black	1276  black	1276  black	1276  black	1276  black	1318  black
TM-14 STYLUS 14 NEW	OMB-15 STYLUS 15 NEW	LM-20; LM-20 H STYLUS 20 NEW	OM-20; OMP-20 STYLUS 20 NEW	CONCORDE 20 STYLUS 20 NEW	TM-20 H STYLUS 20 NEW	LM-30; LM-30 H STYLUS 30 NEW	TM-30 H STYLUS 30 NEW
1336  black	6399 DE  black	1253  black	1253  black	1253  black	1253  black	1255  black	1255  black
OM-30; OMP-30 STYLUS 30 NEW	SME-30 H STYLUS 30 NEW	CONCORDE 30 STYLUS 30 NEW	OM-40 (GOLD) STYLUS 40 NEW	LM-PRO; OM-PRO STYLUS PRO NEW	CONCORDE PRO STYLUS PRO	CONCORDE STD STYLUS STD	DN-167 78 RPM STYLUS
1255  black	1255  black	1255  black	1628  black	1575  silver	1575  silver	1310  silver	1558 DN  black
DN-149 S	DN-150 E	DN-152 E	DN-155 E	DN-160 E	DN-165 E	DN-166 E	THORENS M-200E D-200 E
1354  black	1286  black	1355  black	1284  black	1268  black	1405 DE  black	1406  black	1320  black
M-5 N-5	M-5 P N-5 P	M-10 N-10	M-10 P N-10 P	M-25 S N-25 S	M-25 SP N-25 SP	M-50 E N-50 E	M-50 EP N-50 EP
1719  black	1721  black	1720  black	1722  black	1740  black	1741  black	1743  black	1742  black
305 STYLUS 305	310 STYLUS 310	320 STYLUS 320	520 STYLUS 520	530 STYLUS 530	540 STYLUS 540	N-15 BC	
1759  grey	1760  grey	1761  grey	1762  black	1763  black	1764  black	1757  green	
2M RED	2M BLUE	2M BRONZE	2M BLACK	F/FF-15 MK I/II	F/FF-15 E I/II	OM-SERIES	
6830  red	6832  blue	6834  Bronze	6836  black	6369  white	6369 DE  white	6469 shibata 	

Tonar replacement types for: **OSAWA**

OS-101	OS-102	OS-201	OS-202	OS-301	OS-1001	OS-2001	OS-3001
1567 IM black /grey	1570 grey	1568 IM silver/grey	1571 blue	1569 IM gold/grey	953 white	953DE blue	953DE blue







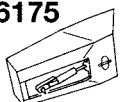

Tonar replacement types for: **OTTO, See: SANYO**

Tonar replacement types for: **PANASONIC, See: NATIONAL**

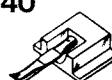

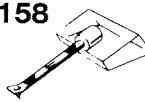
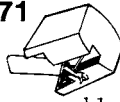

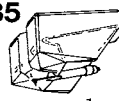
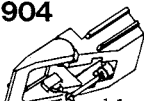

Tonar replacement types for: **PARAMOUNT**

RF-20							
6175 							

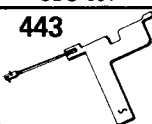
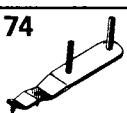
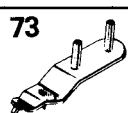
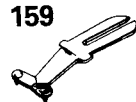
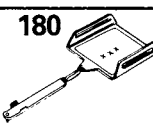

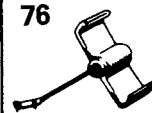
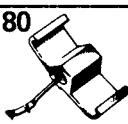
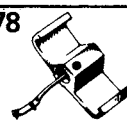
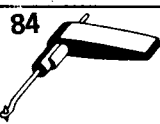
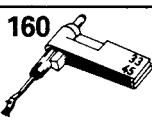
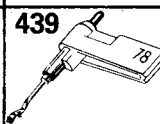

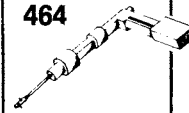
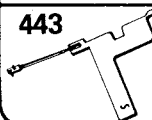
Tonar replacement types for: **PATHE MARCONI**

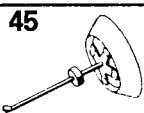
51	53	MUCS; MCS	RC 5/6	STC-7; STC-S; STC-41	STEREO	ST-10 J	STC-2000 D
154 	155 	240 	156 	157 	158 	771 black 	157 
		T-H 5 S	T-H 5 E	STC-10 S			
917 red 	885 transp. clear 	904 black 	904 DE black 	157 			











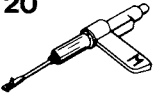







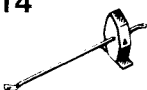





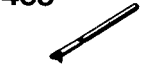
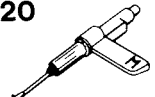



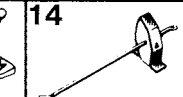





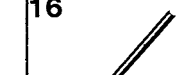





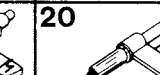

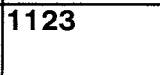
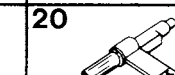



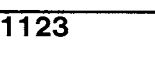
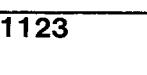
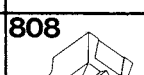
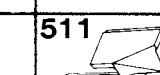
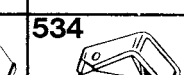

Tonar replacement types for: **PERPETUUM EBNER**

CDS-650; CDS-651	PE 5	PE 8/10	PE 12	PE 30/90	PE TO 48/51	PE 92	PE 180 US
443 	74 	73 	159 	180 	162 	259 	76 
PE 182 US	PE 184 US	PE 186	PE 188	PE 190	223/1	223/2; PE-192	PE 194
80 	78 	84 	160 	439 	356 	357 	464 
PE-3000	PE-7000	PE-8000	PE-9000				
443 	161 	83 	45 				



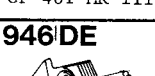
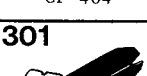
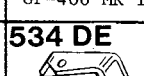
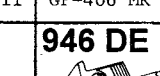
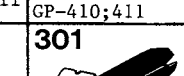
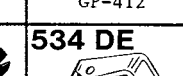

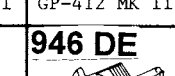
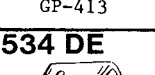
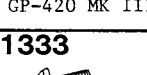
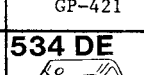
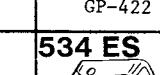
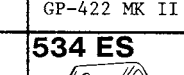
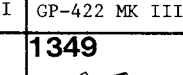
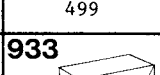
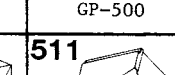
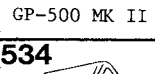
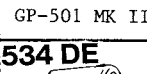
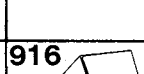
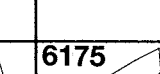

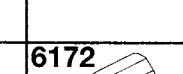
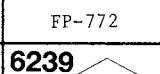
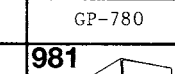
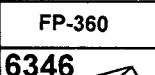
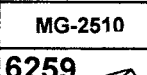
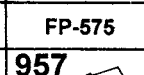
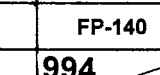
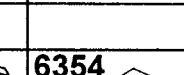
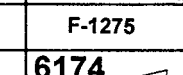
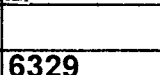
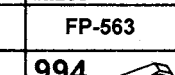









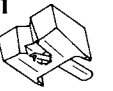
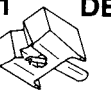







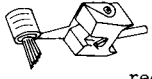
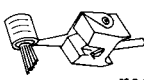
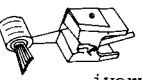
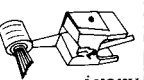
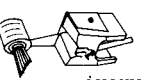
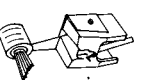
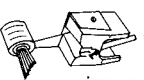
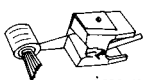

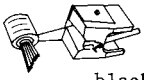
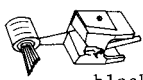
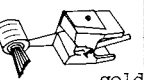

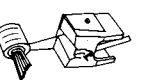
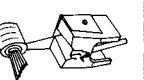
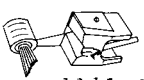
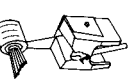
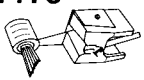
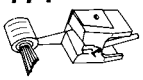
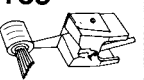
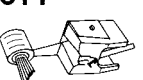

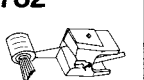
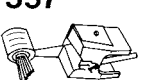
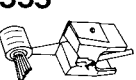
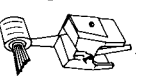
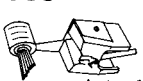

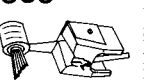
Tonar replacement types for: **PHILCO**

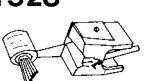
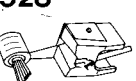
35-2682	35-2775	45-9612	325-8210	325-8214			
164 	137 	163 	258 	165 			















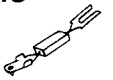
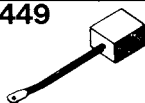









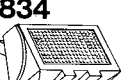
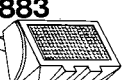

Tonar replacement types for: **PHILIPS**

AU 1010/1020 1030	AG-3001	AG-3010;3012; AG-3013;3015	AG-3016	AG-3019	AG-3020;3021	AG-3025;3026	AG-3027
20 	13 	11 	12 	238 	16 	11 	16 
AG-3052	AG-3063;3066	AG-3109;3113; AG-3114	AG-3201;3202	AG-3201 (D)	AG-3221;3222	AG-3224;3228;	AG-3229
17 	14 	11 	18 	21 	18 	20 	405  stylus only
AG-3230	AG-3304	AG-3301;3302; AG-3304;3305	AG-3306-1	AG-3306;3310	AG-3308	AG-3311 GP-311	AG-3400
20 	14 	15 	247 	20 	14 	280  philitina	19 
AG-3401;3402	AG-3404;3407 AG-3408;3409	AG-3410	AG-5001	AG-5012;5013	GP-200	GP-204;205	GP-212;213
19 	301  blue	19 	17 	16 	20 	543 	553 
GP-214	GP-215	GP-224	GP-228	GP-229	GP-230	GP-233	GP-235
2061  orange	2132  grey	20 	20 	405-C  complete	20 	1123 	20 
GP-300;306;310	GP-316	GP-330	GP-331	GP-350	GP-351	GP-370	GP-371
20 	12 	994  black	994 DE  black	1403  black	1404  black	503  ivory	582  green
GP-380	GP-390	GP-397 MK III	GP-400	GP-400 MK II	GP-400 MK III	GP-401	GP-401 MK II
1123 	1123 	808  green	511  grey	534  black	946  black	511 DE  black	534 DE  black
GP-401 MK III	GP-404	GP-406 MK II	GP-406 MK III	GP-407;408;409 GP-410;411	GP-412	GP-412 MK II	GP-412 MK III
946 DE  black	301  blue	534 DE  black	946 DE  grey	301  blue	534 DE  black	534 DE  black	946 DE  grey
GP-413	GP-420 MK III	GP-421	GP-422	GP-422 MK II	GP-422 MK III	499	GP-500
534 DE  black	1333  black	534 DE  black	534 ES  black	534 ES  black	1349  grey	933  black	511  grey
GP-500 MK II	GP-501 MK II			RB-5400		FP-772	GP-780
534  black	534 DE  black	916  black	6175  red	6262  red	6172  red	6239  blue	981  white
FP-360	MG-2510	FP-575	FP-140		F-1275		FP-563
6346  blue	6259  red	957  black	994  black	6354  black	6174  red	6329  red	994  black

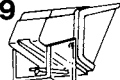
Tonar replacement types for: **PICKERING**

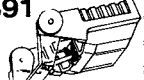
150	150 & Spring	Mark II T-guard	U-38/380 D-3807 A	U-38/380 D-3807 AT	U-38/380 D-3807 C	V-15/D-1507 AC V-15 P/AC	V-15/D-1500ACE V-15 P/ACE
166 	167 	168  red	559  yellow	362  black	558  red	501  orange	501 DE  orange
V-15/D-1507 AM V-15 P/AM	V-15/D-1500AME V-15 P/AME	V-15/D-1507 AT V-15 P/AT	V-15/D-1500ATE V-15 P/ATE	V-15/ .6 Mil.	V-15/PD-07 T V-15 P/DT	V-15/PDE	V-15 series with brush
539  gold	539 DE  gold	465  grey	465 DE  grey	275  black	603  yellow	604 DE  yellow	547  red
V-15 E series with brush	D-IV AC V-15 MICRO AC	D-IV ACE V-15 MICRO ACE	D-IV AT V-15 MICRO AT	D-IV ATE V-15 MICRO ATE	D-IV AM V-15 MICRO AM	D-IV AME V-15 MICRO AME	D-150 DJ XV-15/150 DJ
547DE  red	583  ivory	583DE  ivory	583  ivory	583DE  ivory	583  ivory	583DE  ivory	1530  white
D-350 XV-15/350	D-400 XV-15/400 E	D-625 XV-15/625 E	D-625 DJ XV-15/625 DJ	D-750 XV-15/750 E	D-757 S XV-15/757 S	D-1200 XV-15/1200 E	D-1800 S XV-1800 S
546  black	546DE  black	1166  gold	1334  white	1167  ivory	1612  ivory	1168  gold black	1580  ivory
D-2000 Q UV-15/2000 Q	D-2400 Q UV-15/2400 Q	D-3000 XSV-3000	D-3000 SP XSV-3000 SP	D-3000 XSP-3003	D-3001 E	D-3500 E XLZ-3500 E	D-4000 XSV-4000
1170  black	1171  black/copper	1169  black	1611  silv./black	1169  silv./black	1782  ivory	1557  bronze/black	1555  silv./black
D-4000 SP XSV-4000 SP	D-4000 XSP-4004	D-4500 Q XUV/4500 Q	D-4500 S XLZ-4500 S	D-5000 XSV-5000	D-5000 XSV-5000 U	D-7500 TLZ-7500 S	D-7500 XLZ-7500 S
1610  brown white	1555  silv./black	1172  ivory	1613  ivory	1556  gold white	1556  gold white	1528  gold	1528  gold
DLC TLC	DLE TLE	D-2E TLE MK II	DTL-1 TL-1	DTL-2 E TL-2 E	DTL-2 S TL-2 S	DTL-3 S TL-3	DTL-4 S TL-4 S
1616  white	1617  ivory	1618  ivory	6140 DE  white	1620  white	1621  white	1622  white	1623  white

Tonar replacement types for: **PIEZO**

MS-2;SMT-13	MS-8	SMT-29	03-40729	SC-503	STEREO	Y-100; Y-510	Y-310
27 	170 	169 	380 	148 	449 	370 	270 
Y-565;575;590	Y-640	Y-670	Y-730	Y-930	Y-990	Y-995	YM-101
50  white	367  white	646  green	270 	444  white	NO LONGER AVAILABLE	506  ivory	444  white
YM-114	YM-118	YM-121	YM-122	YM-123	YM-124	YM-125	YM-127
607  white	665  red	753  black	882  orange	834  orange	883  yellow	890  black	949  orange
YM-130	YM-304	YM-308	YM-310	YM-320	YM-818	AN-10	YM-305
NO LONGER AVAILABLE black	NO LONGER AVAILABLE black	734  black	835  black	891  black	6130  green	6072  black	6343  black

Tonar replacement types for: PIONEER

PN-3 MC 1361 MC white/brown	PN-4 MC 1379 MC red	PN-5 MC 1387 MC grey	PN-6 MC 1388 MC white/red	PL-N 6 296 white	PL-N 9 395 white	PN-10; PN-11 396 grey	PN-12 324 red
PN-14 675 green	PN-15 320 red	PN-16 588 grey	PN-20 616 blue	PN-21 6104 ES ivory	PN-30 591 IM red	PN-31 MC 1389 MC blue	PN-33 MC 1243 black
PN-35 574 yellow	PN-41 MC 1390 MC green	PN-50 597 IM purple	PN-K 65 953 white	PN-K 85 710 IM grey	PN-110 324 red	PN-110 MK II 797 black	PN-131 715 orange
PN-135 733 black	PN-150 838 yellow	PN-200 6102 light green	PN-220 851 grey	PN-230 912 green	PN-250 T 6224 black	PN-330 588 grey	PN-330 E 6105 DE brown
PN-330 MK II 774 tr. green	PN-400 799 green	PN-550 E 6106 DE red	PN-550 E MK II 6124 DE tr. smoke	PN-600 800 yellow	PN-770 EX 6107 ES black	PN-800 6103 white	PN-1000 C 6107 ES black
PN-1000 MK II 6125 ES tr. black	PN-7 MC 1600 grey	PN-290 T 6160 IM white	PN-295 T 6167 white	PN-300 T 6160 DE grey	PN-301 1566 black	PN-305 T 6049 black	PN-320 974 yellow
PN-19 6290 grey	PNK-75 6251 IM yellow	PN-210 981 white	PN-240 6287 grey	PN-291 6197 grey	PN-260 6336 grey	PL-2012; PL-2002 6158 blue	



Tonar replacement types for: PRINZ, See: SCHNEIDER
Tonar replacement types for: RADIOHM

MONO; STEREO 177 	CS-60; CM-71 350 						
--------------------------------	--------------------------------	--	--	--	--	--	--



Tonar replacement types for: RADIOLA

GP-500 MK II 534 black	GP-501 MK II 534 DE black	GP-330 994 black	GP-331 994 DE black				
---	--	-----------------------------------	--------------------------------------	--	--	--	--





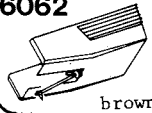
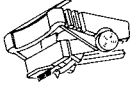
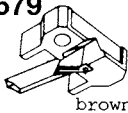
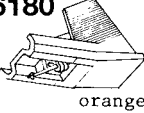

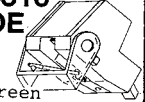



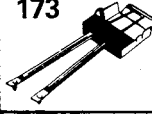

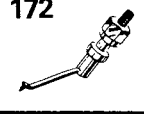
Tonar replacement types for: **Q.E.D.**

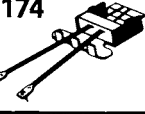
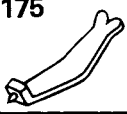
RATA RP-20 diasa ellipt.	RATA RP-40 nude ellipt.	RATA RP-70 ogura vital					
1708  tr. clear	1710  tr. clear	1712  tr. clear					



Tonar replacement types for: **RADIO SHACK**

RT-1500	RXT-4	X-3 N-75 EC	RT-8500	ATN-71 E	ATN-771 E		
6062  brown	901DE 	1679  brown	6180  orange	768 DE  green	6316 DE  green		

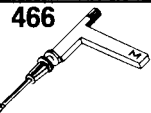
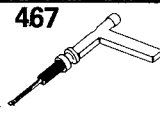
Tonar replacement types for: **R.C.A.**

104; 200; 108800	106969; 106770 106771	74068	75497	100020 A	110020; 110022	115060	115061
173 	297 	171 	172 	261 	174 	175 	176 
115276/115302/ 115303	115329	117330/118197	118199/118200	120695/122057	126566/7	131779/131780	131781/131788
260 	298 	273 	305 	413 	419 	466 	467 

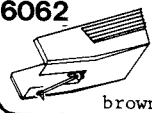
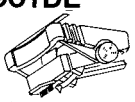
Tonar replacement types for: **REALISTIC**

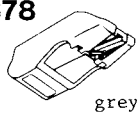
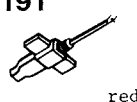
RT-1500	RXT-4	R-47 XT	AT-71 E	QLM-30 MK 3	Clarinette 66		
6062  brown	901DE 	1245 	768 DE  green	878  grey	6191  red		

Tonar replacement types for: **RESON**

33; 78							
178 							

Tonar replacement types for: **REUTER**

N4; S1							
179 							

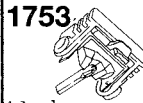

 Tonar replacement types for: **REVOX**

PD-20	Shure Tracer						
1329  black	1753  black						

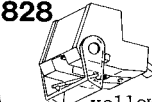
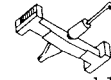
 Tonar replacement types for: **REX (ZANUSSI)**

828  yellow	934  black						
---	--	--	--	--	--	--	--

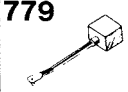
 Tonar replacement types for: **RIGONDA**

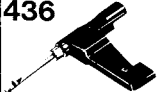
rigonda 123	complete cartridge	2163	ACCORD MONO COMIX	Rigonda			
779 	2163 	436 	2563	6480 original			



 Tonar replacement types for: **RION**

NP-01 D							
379 							

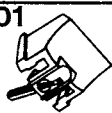

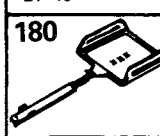
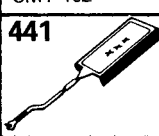
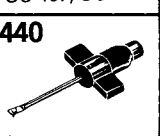
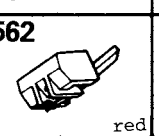
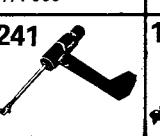
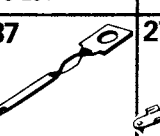
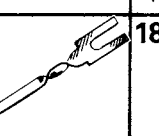

Tonar replacement types for: ROELOFS

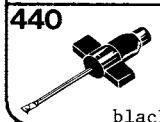
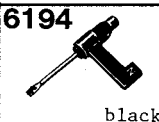
RD-121							
601 							



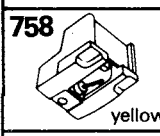
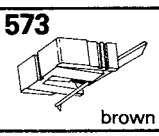
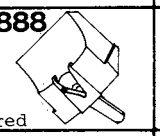
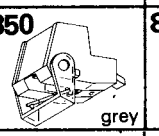
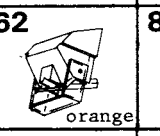
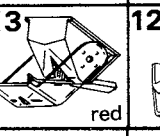
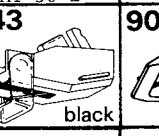

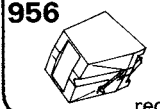
Tonar replacement types for: RONETTE

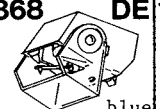
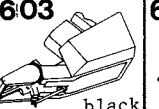
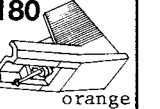
BF 40	CMT-102	SC-107; SC-109	SM-500/7	TA 600	TO 284	TO 284 OE	TX 88
180 	441 	440 	562  red	241 	137 	27 	181 
SC-103	107 (double)						
440  black	6194  black						



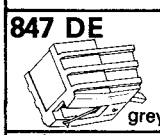
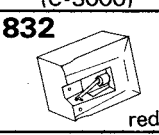
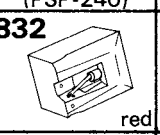
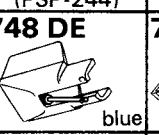
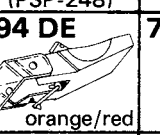
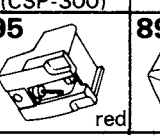
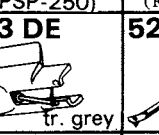
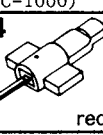
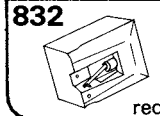

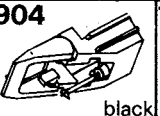
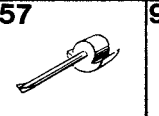
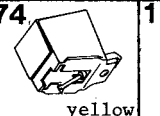
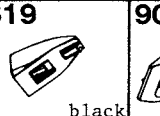
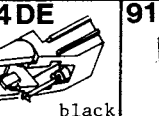





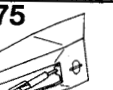

Tonar replacement types for: ROTEL

2 RC-5	2 RC-3	2 RC-4	2 RN-5	2 RC 1	SYSTEM 400	RMC-7 AT-30 E	AT-51 E
758  yellow	573  brown	888  red	850  grey	862  orange	813  red	1243  black	904 DE  black
		ATN-110 E		RT-8500			
956  red	981  white	868  blue	DE 1603  black	6180  orange			

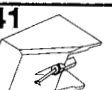
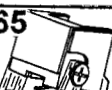
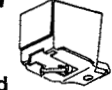
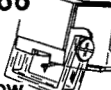





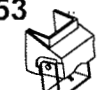



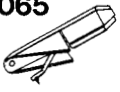





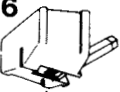



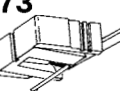

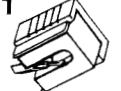
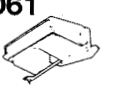











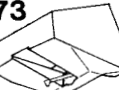
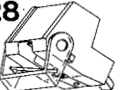

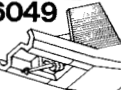
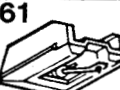
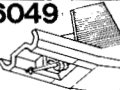





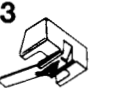

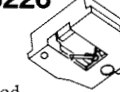

Tonar replacement types for: SABA

ATX-11 E	CN-5431 (C-3000)	AT-3400 (PSP-240)	AT-12 E (PSP-244)	AT-13 EaV (PSP-248)	AT-71 (CSP-300)	ATN-12 ES (PSP-250)	C-2500 (RPC-1000)
847 DE  grey	832  red	832  red	748 DE  blue	794 DE  orange/red	795  red	893 DE  tr. grey	524  red
AT-3400 (PSP-100)	DISCO CENTRE		STC-10 S		OMB-5 (PSP-45)		PSP-15
832  red	157 	904  black	157 	974  yellow	1319  black	904 DE  black	917  red

Tonar replacement types for: **SAMSUNG**

LP-4	150; 350	4237	VIP-550			CN-108	
956  red	822  white	813  red	6240  violet	6175  red	974  yellow	6241  orange	6265  orange
VIP-580L			SCM-6500L				SCM-8900
917  red	6166  yellow	6230  green	6329  red	6240  violet	6049  black	6258  red	6353  grey

Tonar replacement types for: **SANSUI**

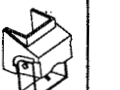
ST-2 D	ST-3	ST-6 D	ST-9 D	SN-10;SN-10 A	ST-10 D	SN-21; SN-22	SN-23
6065  white	269  black	296  white	6067  black	513  transp. black	399  white	296  white	399  white
SN-24	SN-25;MCI-5	SN-26	SN-27	SN-28	SN-29	SN-31;ST-3200 V-3030	SN-37;SC-37
6067  black	538  green	573  tr. brown	689  black	651  black	6061  red	590  grey	710  grey
SC-37 A; SN-70	SN-41	SN-42	SN-43	SN-44	SN-45	SN-50	SN-60;SC-60
6010  red	712  orange	713  tr. clear	6112  purple	823  black	824  black	825  orange	877  orange
SN-70 SC-37 A	SN-80 SC-80	SN-101 SV-101	SN-202	SN-303	SN-P 313	SN-505	SN-P 515
6010  red	673  red	828  yellow	898  yellow	935  black	6049  black	961  grey	6049  black
SN-707	SN-909	ATN-3100	ST-3200	SN-33	SN-36	SN-38	SN-110
985  blue	6060  black	1372  black	590  grey	542  white	6281  orange	663  red	6252  tr. brown
SV-111	SNP-212	SN-757	SN-40 X	SN-1112	SN-3601	SN-3601/II	
6247  red	6234  red	6226  red	620 ES  grey	6279  orange	6279  orange	6279 DE  orange	
SN-343	SN-333	AT-113; SN-353	PE-570	AT-3609	AT-370SS		
6166  yellow	6208  blue	6348 orange  orange	6348 orange  orange	6237  grey	6353  grey		

Tonar replacement types for: **SANWA**

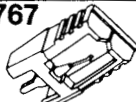
9020							
767  white							

















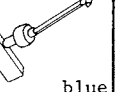
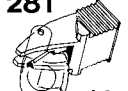
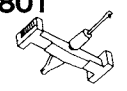
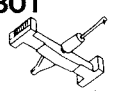

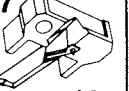
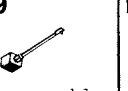

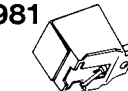
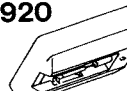

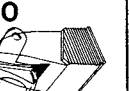

Tonar replacement types for: **SANYO**

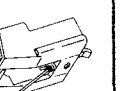
STA-1 D	STG-1	STL-1	STG-2 D ST-107	ST-03	ST-3 D	STA-3 D	STG-3
6096 DE  yellow	578  black	148 	822  white	951  white	50 	781 DE  brown	211  white
ST-4 D STL-40 T	ST-05	ST-5 D MG-2	STG-5 MGT-45	ST-L 5D	ST-6;ST-6 D MGT-1	STG-6	ST-07 D
787 NO LONGER AVAILABLE  white	6175  red	514  white	801  black	6050  1.blue	367  white	801  black	6228  MM ed
STG-7	ST-8;42 K MGT-2	ST-08 D	STG-8	STG-9	ST-09D STW-17 J	ST-10 D MGT-3	STG-10
826  orange	575  white	6229  black	813  red	980  red	6259  red	536  nickle	6282  blue
ST-10J;ST-11D MG-10;MG-10J	STG-11	STM-11 MG-M 11	ST-12 D MG-3	STG-12	STG-13 GXT-250	ST-14 D MGT-5	ST-15 J
771  black	6240  violet	989  dark grey	296  white	6208  violet	6172  red	456  ivory	971  white
ST-15;MG-15 ST-15 GD;LD	ST-17 D MGT-17	MG 17-10	ST-20 J	ST-20 D MG-2	ST-25 D MG-25	ST-25 J	ST-26 D MG-26
573  tr.brown	767  white	980  red	954  black	738  black	526  blue	542  white	691  orange
ST-26 DL	ST-26 J	ST-27 D MG-27	ST-27 DL MG-27 L	ST-28 D MG-28	ST-29 D	ST-30 D MG-30	ST-30 J
6011  black	915  white	608  blue	738  black	663  red	972  MM red	633  red	1243  black
ST-31 J	ST-34 D	ST-35 D	ST-35 VD MG-35 V	ST-36 D MG-36	ST-36 VD	ST-37 D	ST-37 LD
833  red	6012  black	851  grey	571  white	652  orange	568  red	382  blue	6017  tr.dark blue
ST-38 D ATN-892	ST-40 D	ST-40 DX MG-40 X	ST-41 D	ST-41 J	ST-41 ZD	ST-42 D	ST-43 ST-43 D
928  black	6149  orange	694 ES  4-channel tr.brown	865  orange	851  grey	903  blue	898  yellow	771  black
ST-44 D	ST-44 J	ST-45 DX	ST-47 D	ST-48 D	ST-50 D	ST-50 D MG-50	STP-50 J
839  black	6063  blue	688 ES  4-channel blue	6199  black	822  white	951  white	788  black	393  black
ST-51 J	ST-51 D	ST-53 D	ST-53 ZD MG-53 Z	ST-55 D	ST-57 D	ST-63 D	ST-66 D
406  red	904  black	849  brown	849  brown	6195  MM orange	6200  black	760 DE  blue	6164  red
ST-67 D	ST-100 SD	ST-101 SD	ST-102 S ST-102 SD	ST-103 SD	ST-107	ST-140	ST-170 GXT-170
6198  tr.black	840  black	975  black	6036  black	957  black	822  white	6172  red	801  black
ST-707J GXT-210	GXT-210 GXT-410	STW-8J DN-239		ATN-750		STW-40	all plastic
6175  red	6016  blue	981  white	6261  orange	865  orange	6064  orange	6239  blue	6068  grey

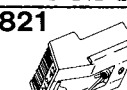
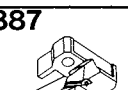
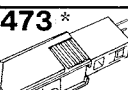
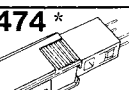
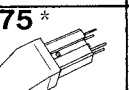
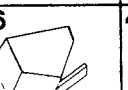
Tonar replacement types for: **SATIN**

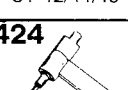
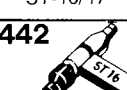
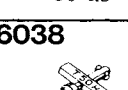
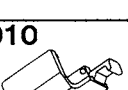
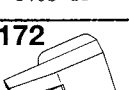
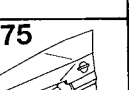

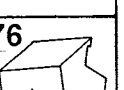

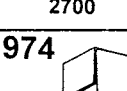
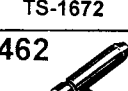







117 NS							
1370  white							

Tonar replacement types for: **SCHNEIDER**

L-3	L-4	Q-4	P-24	SPP-26	QLM-30 MK III	SPP-30	T-30 MS
1251  blue	1400  blue	1401  red	940  tr.orange	973  white	1229  grey	857 DE  tr.red	948  blue
ULM-40 S	SP-60 N	SP-61 M	SP-62 M	ATN-70	M-74 CS SBD-71	KS-231	DN-236
1281  black	801  black	801  black	813  red	795  red	617  blue	779  blue	1311  black
DN-239					DN-145 E	D-155-17	DN-211 DMS-210
981  white	920  white	832  red	651  MM, black/white	384  black	970 	750 	732 
DN-221 DMS-220	DN-242 DMS-242 E	DN-325	MMD-340	MMD-345	MMD-360 E	CN-933	KS-40 A
820 	821 	387 	2473 * 	2474 * 	2475 * 	676 	462 
ST-12/14/15	ST-16/17	T-50 HS		1403 TS			
424 	442 	6038 	910 	6172  red	6175  red	6259  red	6176  white
	2700	TS-1672					
6329  red	974  yellow	462 					

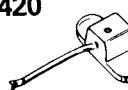
* = Complete cartridge only !

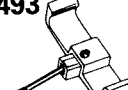
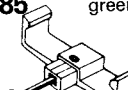
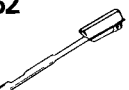

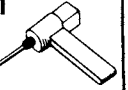



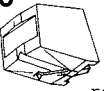

Tonar replacement types for: **SCHUMANN**

FANFARE	HMV-1	HMV-2	SC-474	SK 451	SK 452	SK 453	SK 456; STK 494
182 	390 	391 	153 	183 	184 	185 	186 
STC-480	STC-485/486	STC-487	STC-488	STK-490	STK-495/1	STC-481	
420 	414  jupimatic	493  black	685 green 	152 	239 	391 	

Tonar replacement types for: **SCIENTELEC**

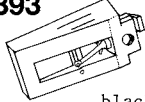
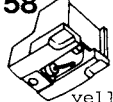
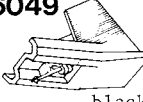
1108  black							
---	--	--	--	--	--	--	--

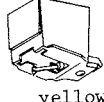





Tonar replacement types for: **SCOTT**

20 SC	21 SC	21 ASC	ATN-3482 P				ATN-3660 YL
956  red	879  red	966  red	6126  yellow	393  black	758  yellow	6049  black	6203  yellow
974  yellow	6164  orange						

Tonar replacement types for: **SEARS**

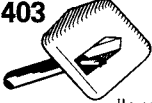
910  white							
--	--	--	--	--	--	--	--

Tonar replacement types for: **SEEBURG**





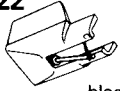









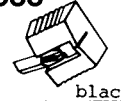

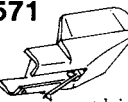
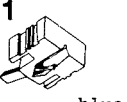

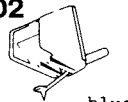
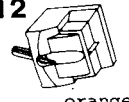

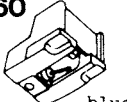



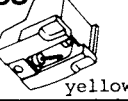
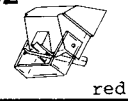

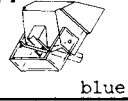



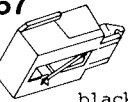
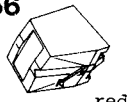

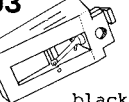
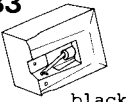
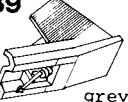
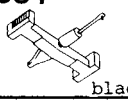
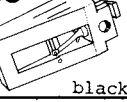
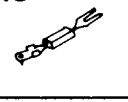
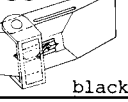
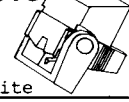
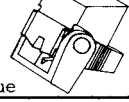
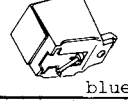
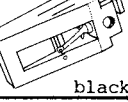



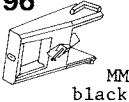

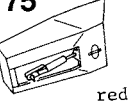

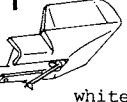
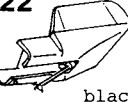



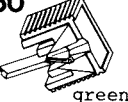
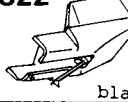

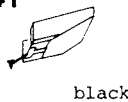

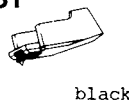
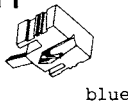

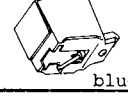

JUKE BOX	MK II	R 150	SHOWCASE	STEREO	D-102	M-100C	
188  blue	168  red	166 	403  yellow	187  turquoise	182 	303 	

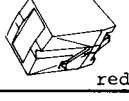
Tonar replacement types for: **SETTON**

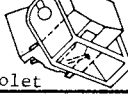
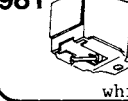
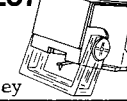

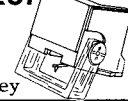







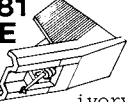

322  black							
--	--	--	--	--	--	--	--

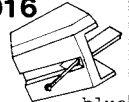
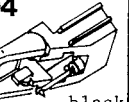
Tonar replacement types for: **SHERTON**

sherton							
1455 							

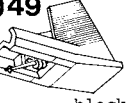
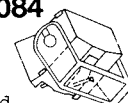
N-03 D	N-05 D; N-06 S	N-08 D	N-09 D	N-14 D	N-15 D	N-16 D	N-17 D
544 	296  white	348 	372 	653  black	6066  black	653  black	398  grey
N-20 D	STY-100	STY-101 STY-111	STY-102	STY-103	STY-104	STY-105	STY-107
571  white	711  blue	730  white	702  blue	712  orange	651  MM black	760  blue	6047  tr. smoke
STY-113	STY-114	STY-115	STY-116	STY-117	STY-118	STY-120	STY-121
148 	710  IM silver	758  yellow	862  red	822  white	851  grey	941  blue	905  black
STY-122	STY-123	STY-124	STY-127	STY-128	STY-129	STY-130	STY-131
992  MM blue	916  black	957  black	956  red	913  black	393  black	933  black	989  grey
STY-132	STY-133	STY-134	STY-135 RP-P8	STY-136 RP-155	STY-137 RP-255	STY-138	STY-139
934  black	393  black	148 	6059  black	6015  white	6014  blue	6037  blue	393  black
STY-140	STY-141	STY-142	STY-143	STY-144	STY-145	STY-146	STY-147; STY-148 STY-149
987  dark blue	991  grey	991  dark grey	6148  MM grey	6196  MM black	6253  IM grey	6175  red	980  red
STY-150	STY-202	STY-213	STY-450	STY-451 ETC.	STY-550	STY-555	STY-701
6228  red	571  white	322  black	653  black	148 	6083  green	705  ivory	660  green
STY-703	STY-704	STY-705	STY-706	STY-707	STY-717	STY-750	STY-751
322  black	456  white	696  ivory	641  black	578  black	681  black	711  blue	722ES  white
STY-752		RP-23; RP-35	RP-50		SG-20 music centre	CN-2423	STG-12
697  orange	6064  orange	987  blue	6085  white	910  white	956  red	795  red	6208  violet
DN-239	SGF-10	STY-112	STY-155	STY-158	STY-152	STY-154	STY-161
981  white	6237  grey	6288  MM blue	6237  grey	6259  red	6331  grey	6332  brown	6282  blue

Tonar replacement types for: **SHERWOOD**

AT-112 EP	MG-1710	ATN-3472 EP					
979DE  blue	980  red	581 DE  ivory	6127 DE  green	6016  blue	904  black	898  yellow	917  red
ST-870			OMB-5	CN-251 MG-2831	PD-604-2		
974  yellow	6049  black	6084  red	1494  black	6365  yellow	974  yellow		











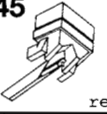
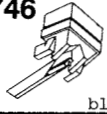
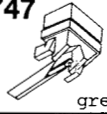
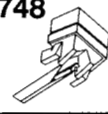
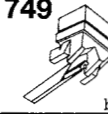
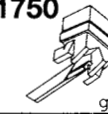





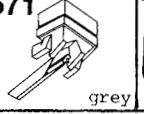
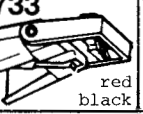
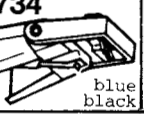
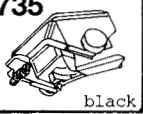
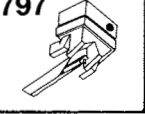
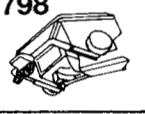
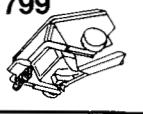

Tonar replacement types for: **SHURE**

M-3 D	PC-6 WC-6	M-7 D	M-8 D	PC-9 WC-38	SPS series N-11	SPS series N-12	PC-12 WC-32
194  gold	191  nickle	245  silver	284 	190 	6321 DE  brown	6322 DE  orange	193 
SPS series N-13	SPS series N-14	PC-20;WC-20	M-21 D	M-24 H	M-31 E	M-32 E	M-33-5
6323 DE  tan	6324 DE  blue	196 	195  gold	707 ES  gold	1037  yellow	1080 	242  red
M-33-7	SC-35 C SS-35 C	SC-39 B	SC-39 EJ	SC-39 ED	PC-42	ML-44 PC-2	M-44-5
243  white	967  blue	1272  beige	1273  green	1274  orange	10 	192  nickle	267-5  red
M-44-7	M-44-C	M-44 C with guard	M-44 G	M-44 E	M-55-E	M-70 B	M-70 EJ
267-7  white	360  blue	6020  light blue	6361 	1039  brown	274 DE  yellow	743  beige	744 DE  green
M-72 B	M-72 EJ	P-72 W-68	M-71;M-75 6S M-75 6;M-75 MB	M-75 B type II	M-75 G	M-75 G type II	M-75 C
1304  beige	1305  green	189 	387  beige	518  beige	386  grey	519  grey	617  blue
M-75 E	M-75 EJ type II	M-75 ED type II	M-77	M-81 MC	M-91 G	M-91 GD	M-91 E
385 DE  yellow	517 DE  green	520 DE  black	197  black	617  blue	401  grey	615  red	469 DE  black
M-91 ED	M-92 G	M-92 E(old)	M-92 E (new)	M-93 E	N-94 EP	M-95 G	M-95 EJ
623 DE  yellow	472  grey	474 DE  yellow	6097 DE  red	500 DE  green	1638  blue	678  grey	1221  green
M-95 ED	M-95 HE	Ne-95 ED Me-95 ED	N-96 LT	M-97 B	M-97 EJ	M-97 ED	M-97 HE
638 DE  yellow	1218  black	1246  encore series	1729  yellow	901  black	1300  black	901 DE  black	901 ES  black
M-97 LT	Me-97 HE Ne-97 HE	M-99 E	M-104 E	M-105 E	M-110 HE	M-111 HE	M-120 HE
6018  red	6285 ES  red	6098 DE  blue	6099 DE  yellow	1440  black	6100 ES  white	1442  red black	1443  black red dot
M-140 HE	NDC-EJ	NDC-ED	SDS-1	SDS-3 NDC-HE	RXT-4	N-15	N-16
1444  black white dot	1245  black	1246  black	6019 	6327 ES 	901 DE 	6325 DE  green	1753  black
NSM N-17 CM JUKEBOX NDL.	NV-30 HE	N-75 EC 3 X	N-75 HE/ II		Whitelabel	M-44-7 competition	
605  blue	6320 ES  black	1679  brown	6326 ES  grey		1977  blue	1937  white	





CONTINUED

Tonar replacement types for: **SHURE**



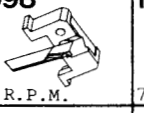
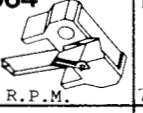
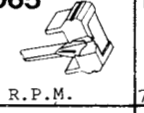

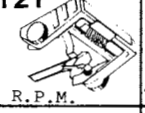
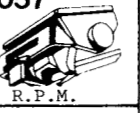
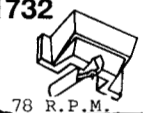
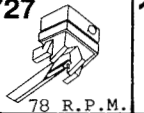

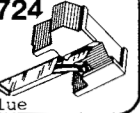

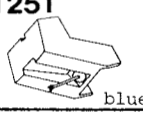
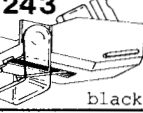

CONTINUED

SS-40 DC-40	SS-50 DC-50	SS-60 DC-60	SS-70 BC-70	SS-80 BC-80	SS-90 BC-90		VN-35 MR V-15 type III
1745  red	1746  blue	1747  green	1748  red	1749  blue	1750  green		584 shibata 
VN-2 E V-15 type I	VN-15 E V-15 type II	VN-35 E V-15 type III	VN-35 HE V-15 type III	VN-45 HE V-15 type IV	VN-45 MR V-15 type IV	VN-45 LT V-15 LT	VN-5 HE V-15 type V-B
1084  black	567 DE  black	584 DE  black	584 ES  black	798 DE  black	1120  black	1483  black	6420 ES  shibata
VN-5 MR V-15 type V MR	V-15 type V P VN-5 P	ULTRA 300 S	ULTRA 400 S	ULTRA 500 S	VNSE3HE VST III P	VNSE3HE VST III	VNSE5MR VST V
6420 shibata  silver black	1671  grey	1733  red black	1734  blue black	1735  black	1797 	1798 	1799 
M-97 XE	M-97 XE	V-15 II ; VN-15 E	V-15 III ; VN-35 MR	V-15 IV ; VN-45 MR	V-15 V x/MR	V-15 V MR	V-15 V x/MR
1959 	6441 D-SAS 	6416 D-SAS 	6407 D-SAS 	6409 D-SAS 	6430 shibata 	6425 D-SAS 	6435 D-SAS 

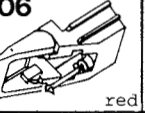

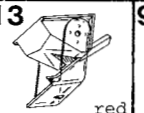

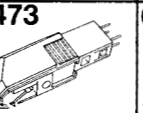

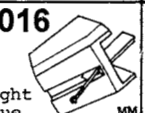
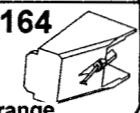
Tonar replacement types for: **SHURE - 78 RPM -**

N-44 3 M-44;55 series	N-70 3 M-70;72 series	N-75 3 M-75 series	N-91 3 M-91 series	N-95 3 M-95 series	VN-78 E V-15 type III	VN-478 E V-15 type IV	VN-578 E V-15 type V
1222  78 R.P.M.	1098  78 R.P.M.	1064  78 R.P.M.	1065  78 R.P.M.	1223  78 R.P.M.	1122  78 R.P.M.	1121  78 R.P.M.	1057  78 R.P.M.
SS-78 E SC-35 C	N-78 E	N-978 E (M-97)				N-32-3	N-44-1
1732  78 R.P.M.	1727  78 R.P.M.	1827				1784  78 R.P.M.	1724  blue

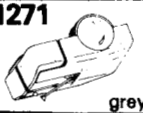

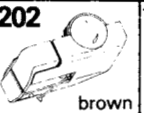
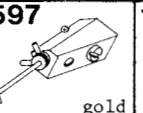

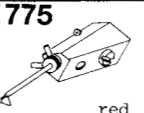
Tonar replacement types for: **SIEMENS**

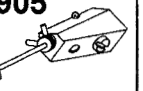
L-3	AT-30 E	QLM-30 MK III	RW-150	DN-239	555		
1251  blue	1243  black	1229  grey	898  yellow	981  white	794 DE  orange	406  red	758  yellow
		RS-226		MMD-340		CN-213	
760  blue	813  red	910  white	974  yellow	2473  MM blue	6208  MM blue	6016  light blue	6164  MM orange

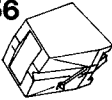
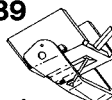
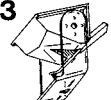
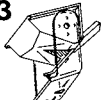
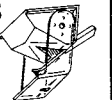
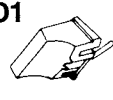
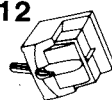
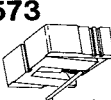
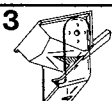
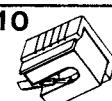
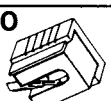
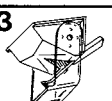
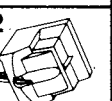
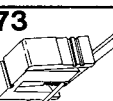
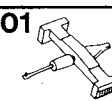
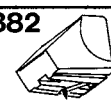
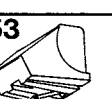

Tonar replacement types for: **SIGNET**

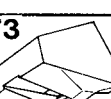
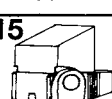
TKN-3EA	TKN-1; TK-5E	TKN-2; TK-7E	TKN-3; TK-7SU	TKN-9 LCA TKN-9 LCA	TKN-7 LCA TK-7 LC	MRN-05 BASIC	TKN-9 Ea
1271  grey	1200  blue/grey	1201  brown	1202  brown	1597  gold	1639  brown	1690	1775  red
TKN-5EA	TKN-6; TK-3E	TKN-7 LCA	TKN-22	TKN-29; TK-9E; TK-10			
1823	1777	1639	6446 	6905 			

Tonar replacement types for: **SILVER**

SLU-30 956  red	SYSTEM 70 839  black	SYSTEM 70 813  red	SYSTEM 75 813  red	SS-85 813  red	SYSTEM 90 601  orange	SYSTEM 100 712  orange	SYSTEM 110 573  brown
SS-170 813  red	SYSTEM 200 710  IM grey	SS-250 710  IM grey	SS-270 813  red	SYSTEM 300 712  orange	SYSTEM 1500 573  brown	SS-3850 801  black	SL-5030 882  orange
SL-5050 753  black	S-8300 934  black	673  red	SL-90 6015  white	SL-770 6259  red			

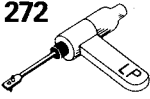
Tonar replacement types for: **SINGER**

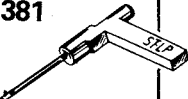
PU-1300 272 	PU-1357 349 	PU-3012 381 					
--	--	--	--	--	--	--	--











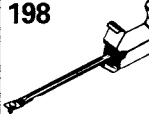
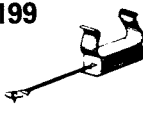

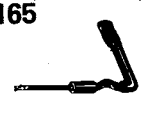
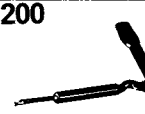
Tonar replacement types for: **SONIC**

S-10 C 725  orange							
---	--	--	--	--	--	--	--

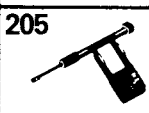
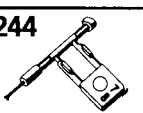
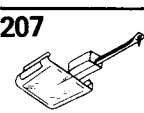
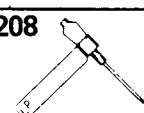

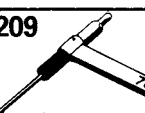
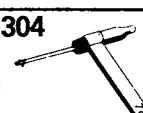
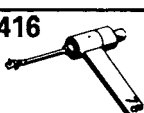
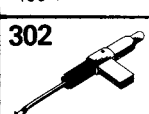
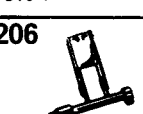
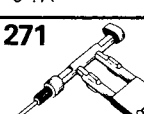
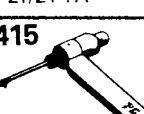
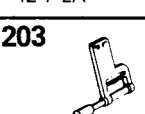
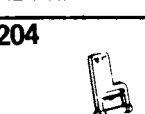
Tonar replacement types for: **SONICA**

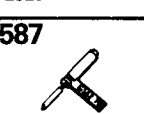
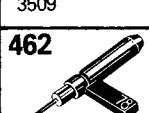
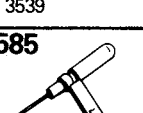
SK-58 C 792  tr. yellow	SK-20 s no longer available yellow						
--	--	--	--	--	--	--	--

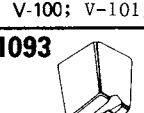
Tonar replacement types for: **SONOTONE**

1 P 198 	3 P 199 	2 T 258 	3 T 165 	8 T; 8 TA 8 TA-77 200 	9 T 201 	12 T 202 	14 T 180 
16 T 205 	18 T 244 	20 T 207 	21 T; 22 T; 23 T 208 	25 T; 28 T 262 	26 T; 27 T 209 	32 T; 39 T 304 	60 T 416 
100 T 302 	916 T 206 	9 TA 271 	21/24-TA 415 	12 T-LA 203 	12 T-HR 204 	2109; 2509; 2539 435 	2529 587 
3509 462 	3539 585 	3559 586 	V-100; V-101 1093 black 				

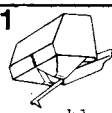
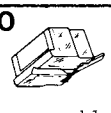
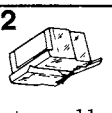

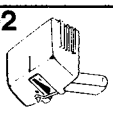
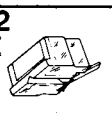

Tonar replacement types for: **SONOVOX**

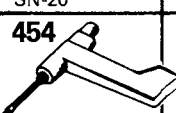
N-11 S 791  black	50 S 790  blue	S-101 C 792  tr. yellow	S-101 E 792 DE  tr. red	S-101 SH 792 ES  tr. clear	SN-300 602 	TC-812 E 792 DE  tr. red	
--	---	--	--	---	---	---	--



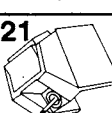

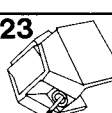
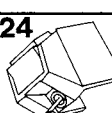
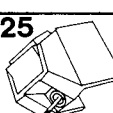
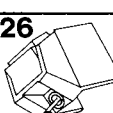
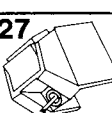
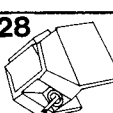
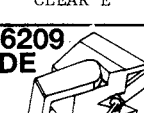
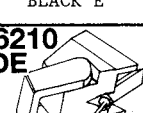
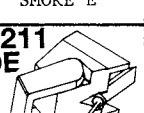
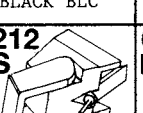
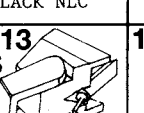

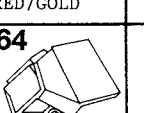



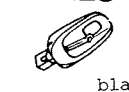
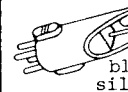





Tonar replacement types for: **SONTRA**

SN-20 454 							
--	--	--	--	--	--	--	--

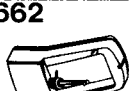



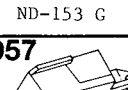
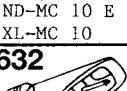









































Tonar replacement types for: **SONUS**

SR-202 1421  brown	BLACK A BLACK C 1422  white	SILVER E 1423  white	SILVER P 1424  white	BRONZE 1425  brown	GOLD BLUE 1426  white	SUPER BLUE 1427  blue	DIMENSION 5 1428  black
CLEAR E 6209 DE  clear	BLACK E 6210 DE  black	SMOKE E 6211 DE  smoke	BLACK BLC 6212 ES  black	BLACK NLC 6213 ES  black	GREEN/GOLD 1666 	RED/GOLD 1664 	

Tonar replacement types for: **SONY**

ND-MC1 E XL-MC 1 1452  red/silver MC	ND-MM1 G XL-MM 1 6022  tr. orange	ND-MM2 E XL-MM 2 6022 DE  tr. red	ND-MC3 X XL-MC 3 1453  brown/silver MC	ND-MM3 X XL-MM 3 6022 IES  black	ND-MC5 X XL-MC 5 1478  black/silver MC	ND-5 G VL-5 848  blue	ND-7 E 848 DE  blue
ND-14 G VL-14 GS 773  orange	ND-15 G XL-15; VL-15G 731  orange	ND-15 GA XL-15 A 731  orange	ND-20 G VC-20 1303  silver	ND-ST 21 556 	ND-25 E XL-25; XL-25A 854 DE  grey	ND-30 E XL-30 881 DE  blue	ND-35 E XL-35 855 DE  tr. red
ND-45 E XL-45 E 765 DE  tr. purple	ND-45 X XL-45 754 ES  tr. purple	ND-45 X II XL-45 II  orange	ND-50 G VX-50 G 742  orange	ND-50 X XL-50 6095 DE  orange	ND-60 G VX-60 G 807  red	ND-70 X XL-70 458 DE  tr. red	ND-100 G VL-100 G 727  green
ND-108 VM-8 GS 816  red	ND-111 E/112 E VM-8 E 679 	NS-113 P VM-9 P 296  white	ND-114 P VM-10 P 531  red	ND-115 G VM-11 G 693  black	NS-116 P VX-12/13 148 	ND-117 P VM-15 P 498  orange	ND-119 P/VX-17 P ND-120 P/VX-18 P 497  green
ND-121 P VM-19 P 505  red	ND-124 P 499  red	ND-125 G VM-21G; 21P 499  red	ND-126 G VM-22 GA 496  black	ND-127 P VX-23 P 532  red	ND-128 P VX-24 P 316  black	ND-129 G VM-25 G 571  white	ND-130 G 323 ES  4-channel
ND-131 G VM-1200 G 635  blue	ND-132 G VM-22G; VM-26G 612  black	ND-133 G VL-30 G 613  green	ND-134 VL-32 G 662  red	ND-134 G VL-34 G 662 DE  yellow	ND-135 G VM-27 G 778  red	ND-136 G VL-33 G 795  red	ND-137 G VL-37 G 819  yellow
ND-138 G VL-38 GS 832  red	ND-139 G 904  black	ND-141 G VC-41 G MC 1626  red	ND-142 G VL-42 G 974  yellow	ND-143 G VL-43 G 977  tr. blue	ND-144 G VL-44 G 6165  lilac	ND-145 G VL-45 G 581  grey	ND-147 6064  orange
ND-150 902  green	ND-150 G XL-150 907  tr. red	ND-156 G 	ND-200 G XL-20 G 919  tr. blue	ND-200 E XL-20 880 DE  blue	ND-220 G VL-20 863  red	ND-250 G XL-250 G 880  tr. red	ND-301 P 6170 
ND-333 E XL-333 1451  purple/black MC	ND-500 E XL-500 E 1454  red/silver MC	ND-1500 XL-15; XL-25 1510 ND-15 black for classic ND-15 orange for jazz	ND-40 E XL-40 1479  tr. purple	ND-10 G XL-10 6145  white	ND-142 GP 6155  pink	ND-142 EP 6155 DE  pink	ND-142 EY 974 DE  yellow
ND-148 G 6208  blue	ND-152 P 6174  red	ND-153 G 957  black	ND-155 G 981  white	ND-250 E XL-250 E 6147  yellow	ND-300 G XL-300 6143  red	ND-105 6346  blue	
ND-MC 2 E XL-MC 2 1697  red/silver MC	ND-MC 10 E XL-MC 10 1632  orange/black MC	PS-212A 758  yellow	CN-234 6259  red	PSLX-49/CN-234 6259  red			









Tonar replacement types for: STANTON

mark V D-5	E-7 S	LZ-8S; HZ-8S E-8 S	LZ-9S; HZ-9S E-9 S	500 A D-5107 A	500 AA D-5105 AA	500 A/ II D-50 A	500 E D-5100 E
1713  black	1642  tr. brown	1581  black	1551  black	549  black	549  black	1653  blue	549 DE  black
500 E/II D-50 E	500 EE D-5100 EE	500 EE/ II D-50 EE	500 AL D-5107 AL	L-500 AL D-57 P-AL	500 EL D-5100 EL	500 series D-5127	600 A D-6071 A
1550  blue	549 DE  black	1654  blue	6364  DISCO white	1637  white	1789  white	1119  78 rpm	964  black
600 E D-6004 E	600 EE D-6003 EE	600 series D-6027	680 AL D-6800 AL		680 EL DISCO D-6800 EL	680 SL DISCO D-6800 SL	680 AMC D-6800 AMC
964 DE  black	964 DE  black	1187  78 rpm	1643  white		6390 DE  white	1350  white	1552  black
680 BPSM D-6800 BPSM	680 BPSR D-6800 BPSR	681 A D-6807 A	681 E D-6800 E	681 EE D-6800 EE	681 EEE D-6800 EEE	681 EEE/S D-6800 EEE/S	681 EEE/S II D-6800 EEE/S II
1553  black	1644  black	548  black	548 DE  black	548 DE  black	669 DE  black	1652  black	1652  black
681 SE D-6800 SE	681 series D-6827	STC-710 D-70 E	L-720 EE D-71 EE	L-725 E D-71-2E	L-727 E D-72 E	STC-730 D-71-2E	L-737 S D-73 S
1112  black	1184  78 rpm	1791  black	1485  black	1790  black	1486  tr. clear	1790  black	1487  tr. clear
L-737 E D-73 E	STC-740 D-72 E	L-747 S D-74 S	L-837 S D-83 S	L-847 S D-84 S	881 S D-81	881 series D-827	980 LZS D-98 S
1488  tr. clear	1486  tr. clear	1489  tr. clear	1640  white	1641  white	805 DE  white	1185  white 78 R.P.M.	1352  tr. clear

Tonar replacement types for: STARE



210 							
---	--	--	--	--	--	--	--

Tonar replacement types for: STEEL NEEDLES











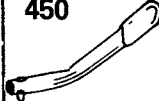

Laubscher forte 11	EDISON CILINDER	Laubscher PPP 34	VERY SOFT TONE	SOFT TONE	MEDIUM LOUD TONE	LOUD TONE	VERY LOUD TONE
1886  BOX 200 PCS. 15.0 x 1.5 MM	6317  AMBEROLA	1888  BOX 100 PCS. 15.5 x 0.8 MM	6459  BOX 100 PCS. 16.0 x 0.8 MM	6460  BOX 100 PCS. 18.0 x 1.0 MM	6461  BOX 100 PCS. 17.0 x 1.4 MM	6462  BOX 100 PCS. 18.0 x 1.5 MM	6463  BOX 100 PCS. 16.0 x 1.7 MM

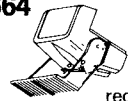
In old 78 RPM record players – so called Pathé-phones – there was no amplifier. Instead the volume is controlled by the shape and the dimensions of the steel needle. We are proud to announce newly manufactured steel needles which are available in boxes of 100 pcs. and in various tone types like very soft tone, soft tone, medium loud tone, loud tone and very loud tone.

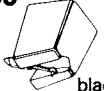
Tonar replacement types for: SUPEX

SM-38	SM-38 E	SMM-5					
984  black	984 DE  black	6214  black					

Tonar replacement types for: **SUPRAPHON / TESLA**







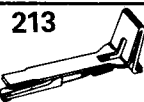

KS-22 378 	VK-311/68317 450 	VK-4302 464  turnover	VM-2101 1052  black	JT-311 555  green	VK-4302 1066 *  single tip	JT-511 664  red	JT-411 761  yellow
E-100 1093  black	VK-4202 1066 	VK-051 27 	VM-2102 1599  black	VM-2103 1834  red	VM-2204 1835  black		

* Naald VK-4302 (T-naald) wordt geleverd als naald voor VK-4202 met gebruiksaanwijzingen.
The stylus for VK-4302 (T-Bar) is delivered identical to the stylus for the VK-4202 along with mounting instructions sheet.

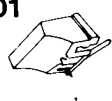
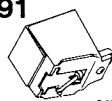
Tonar replacement types for: **TANNOY**

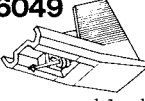

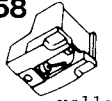







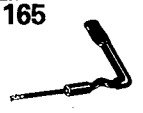
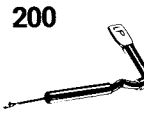
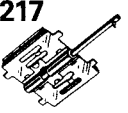
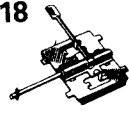

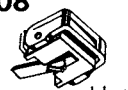

MK-11 213 							
--	--	--	--	--	--	--	--

Tonar replacement types for: **TEAC**



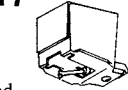

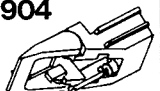



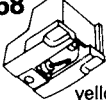

866  black	909  black	601  brown	PC-707 ; N-707 991  grey MM	PC-313 877  red	PCS-708 PC-708 6049  black	898  yellow	758  yellow
P-75 6259  MM red	PX-550 865  orange						

Tonar replacement types for: **TECHNICS, See: NATIONAL**

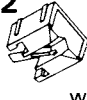

Tonar replacement types for: **TELEFUNKEN**

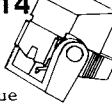
2 TS 258 	3 TS 165 	8 TS 200 	A 20/1; T 20/1 217 	A 20/2; T 20/2 218 	A 23/1 311 	A 23/2; T 23/2 A 25/2; T 25/2 299 	A 200; T 200 219 
TTSA 216 	STYLUS-12 LMA-12 1318 	STYLUS-5 LMA-5 1319 	TM-500 608  blue	TM-600 A-600 D 781 DE  l.brown	ATN-72 895  brown	ATN-3410 898  yellow	917  red
STYLUS 10 NEW OMB-10 1276  black	TM-400 526  blue	904  black	916  black	6242  yellow			

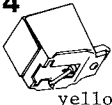







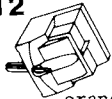

Tonar replacement types for: **TELETON**

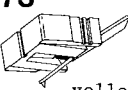
CMS-500/400/ 300	DST-17/S-100 G; CS-400/401	ATN-71	MST-31	MPC-7		MST-5	MST-6
452 	571  white	758  yellow	712  orange	822  white	801 	661  grey	822  white
N-1520	MM-321 B						
6014  blue	945  tr.green	673  red	974  yellow				



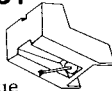

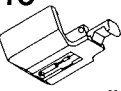
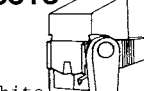
Tonar replacement types for: **TENOREL**

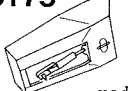
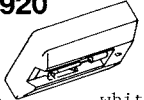
T-2001	T-2001 ED	T-2001 SD					
622  white	622 DE  black	622 ES 					

Tonar replacement types for: **TENSAI**

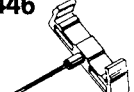

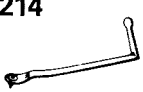

			Jelco 9 A				
831  yellow	712  orange	637  red	573  yellow	813  red	898  yellow	934  black	877  orange
L-3		L-4				MC-390	MC-3750
1251  blue	974  yellow	6042  blue	910  red	6015  white	917  red	801 	6175  red
compo 15 compo 25							
920  white							

Tonar replacement types for: **TEPPAZ**



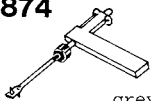
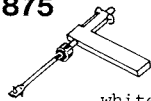

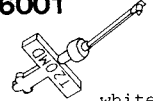

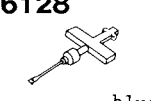
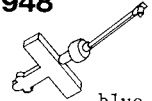



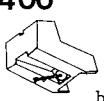
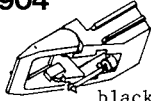

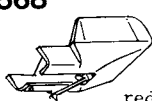
ECO 60/423; 26	MT-30	STEREO	VISSEAU	JUPITER			
292 	446 	215 	214 	557 			

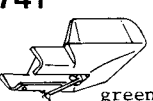
Tonar replacement types for: **TESLA, See: SUPRAPHON**

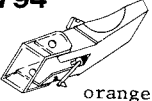
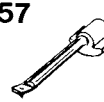

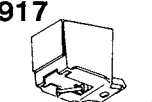
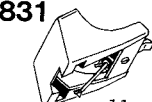
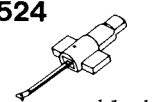
Tonar replacement types for: **TETRAD**

T-5 H	T-2 MS T-2 MD	T-3 MS T-3 MD	T-12 MS T-12 MD	T-20 MS T-20 MD	T-50 HS	T Z-1 S T Z-1 D	T-30 MS T-30 MD
874  grey	875  white	6002  blue	6007  red	6001  white	6038  grey	6128  blue	948  blue





Tonar replacement types for: **THOMPSON**

L-4	T-H 5 S	T-H 5 E	AT-10	ATS-11	ATS-11 E	ATN-12 XE	ATN-13 Ea
1400  blue	904  black	904  black	568  red	677  yellow	741  green	781  brown	794  orange
STC-100 D	STC-1000 D		ATN-3721			DN-105	M-22
157  black	157  black	917  red	831  yellow	524  black	935  black	1529  black	6242  yellow











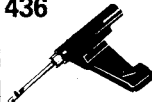
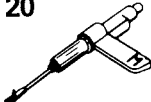
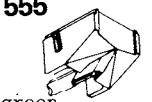

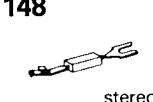
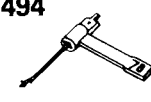



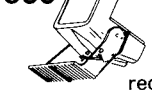

Tonar replacement types for: **THORENS**

M-200 E D-200 E	LMB-12						
1320  black	1318  black						

Tonar replacement types for: **TONACORD**

TM-1000	TM-1000 S	TM-511	TMC-100				
815  5mV yellow	550 ES  white	664  red	2521  black				

Tonar replacement types for: **TONAR**

5-POLE	5-POLE-2	JT-311	JT-322	NC 100; 202; 203 NC 505; 400; 400H	NC 202; 203; 400 NC 400H	NC-700	NC-770
436  black	20  white	555  green	550  white 4-channel	27  black	148  stereo	494  black	270  black
NM-11-A	NM-22	NM-33	NM-33-A	NM-66	NR-1	CDS-650	511
222  gold	263  white	296  white	453  blue	447  grey	363  black	614  black	960  red
511 BE	555	611	611 BE	711 MC	BAKTRAK	DIABOLIC E	BANANA
960  yellow	DE 960  black	6176  white	6177  DE yellow	2521  black	1811  yellow	1953  red	1812  yellow

Tonar replacement types for: TETRAD

IMPORTANT POINTS ON TETRAD NEEDLES — All TETRAD needle models are very similar in construction. The shank portions vary only in the length of the metal vane and the position of the rubber coupler, or bumper. The scale drawings in the middle left side of each illustration block are exact size.

Although the major difference shown in each scale drawing is the length of the handle, there are many vital, significant differences. Engineering specifications such as the rubber flexibility, length and thickness of the tube and material composition are all factors in reproducing the full frequency cycle range, smooth response characteristics and good tonal qualities of sound reproduction.

To determine needle group needed, we suggest placing the old needle directly on the scale drawings until a match is found where shank, bumper, vane and lever-arm drawing agree with actual needle. There may be a slight variation in length of a few thousandths of an inch, which does not affect playback performance.

Lever arm lengths are indicated by the letters A, B, C, D and E in the illustrations. Match the old needle lever arm to determine the arm length needed (A, B, C, D or E). If in doubt, it is advisable to purchase the "E" length and cut off a portion of the lever arm to fit.

PLEASE NOTE: All ALL-PLASTIC needles may be replaced by HIGH-COMPLIANCE METAL NEEDLES. The second column of TONAR numbers under the ALL-PLASTIC needle section gives you immediately the TONAR number of the HIGH-COMPLIANCE needle replacing the ALL-PLASTIC needle concerned.

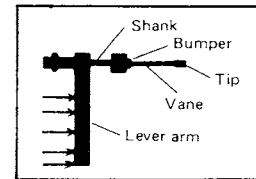

HIGH COMPLIANCE NEEDLES				TONAR NO.		TURNOVER-ARM LENGTH	
NEW	OLD	TETRAD NRS.	ILLUSTRATIONS	NEW	OLD	TETRAD NRS.	ILLUSTRATIONS
281	—	A 50: 60 A-0: B-0: C-0*		330	—	A 70 80 90	
327	332	B 51 61 A-1*: B-1: C-1*		335	—	B 71 81	
328	333	C 53 63 A-3*: B-3: C-3*		337	—	C 73 83 93	
266	294	D 52 62 A-2*: B-2: C-2*		336	—	D 72 82: 92	
329	334	E 54 64 A-4: B-4: C-4		338	—	E 74 84 94	
* ALL PLASTIC NEEDLES							
				TONAR NO.		TURNOVER-ARM LENGTH	
NEW	OLD	TETRAD NRS.	ILLUSTRATIONS	All Plastic	H.C.*	TETRAD NO.	ILLUSTRATIONS
319	324	A 20 40 E-0: G-0		481	327	A A-1	
221	317 282	B 21 41 121 E-1*: G-1*		483	328	B A-3	
293	325	C 23 43 E-3*: G-3*		482	266	C A-2	
283	320	D 22 42 E-2*: G-2*		471	281	A C-0	
321	326	E 24 44 E-4: G-4		484	327	B C-1	
295	322	A 10 30		486	328	C C-3	
220	220	B 11 31: 111		485	266	D C-2	
265	291	C 13 33		487	221	A E-1	
264	316	D 12 32		489	293	B E-3	
318	323	E 14 34		488	283	C E-2	
				490	221	A G-1	
				492	293	B G-3	
				491	283	C G-2	

* Also available as All Plastic type.

* High Compliance replacement for All Plastic needle.

Tonar replacement types for: **TOSHIBA**

TP-102;106; TP-114 27 	TP-102;106 TP-114 148  stereo	N-2 C 148 	N-3 C C-03 C;C-10C 578  black	N-4 CS C-07 296  white	N-04 C C-04 C 508 	N-6 C 148 	N-6 L C-6 L 1474  tr. green
N-6 Z C-6 Z 1476  tr. purple	N-11 C SM-280;290 456  white	N-12 C C-26 M 398  grey IM	N-13 C C-27 M 542  white	N-14 D 571  white	N-20 C 920  white	N-21 D 910  red	N-33 C C-911 876  black
N-34 C;N-35 D C-34 M;C-35 M 887  red	N-40 C 934  black	N-44 6115  blue IM	N-45 C C-45 M 962  orange IM	N-50 C C-50 M 972  red MM	N-51 C 972  red MM	N-52 DY 677  yellow	N-53 DY 568  red
N-55 DY 768  green	N-56 DY 915  grey	N-57 DY 768 DE  green	N-58 C C-58 M 804  tr. violet	N-59 DY 748 DE  blue	N-60 DY 925  tr. purple	N-62 C;N-63 D C-62 M;C-63 M 950  red MM	N-64 C C-64 M 963  red IM
N-66 C;N-67 D C-66 M;C-67 M 950  red MM	N-68 887  red	N-69 D C-69 M 6131  red IM	N-70 C 925  tr. violet	N-71 D C-71 M 832  red	N-72 D C-72 M 935  black	N-80 D C-80 MC 1373  red	N-88 D C-88 MC 1407  green black
N-160 C C-160 M 862  orange	N-210 C C-210 M 826  red	N-220 ME/X C-220 M 6116 ES  red	N-230 C C-230 M 826  red	N-250 C C-250 M 6047  smoke	N-260 C C-260 M 816  red	N-280 C C-280 M 6101  white MM	N-290 D 6052  black MM
N-292 973  white	N-300 C C-300 F 570 	N-301 C C-301 F 508 	N-310 C C-310 M 944  orange	N-320 D C-320 M 914  tr. green	N-330 D C-330 M 914  tr. green	N-400 N-403 S-C 1339 	N-404 C-EX 1348 
N-500 C C-500 6129  tr. green	N-550 C C-550 M 373  tr. blue	N-402 S-D 851  white	C-30 M 6183  red	C-32 M 6154  red	N-74 C C-74 M 6139  grey IM	N-74 DY 6139  red	N-75 C C-75 M 6138  black MM
N-76 DY 6138  black	N-293 DY 851  white	N-78 D 1572  nickle	TP-116 SD 6190  white	N-16 D 917  red	SR-V-22 673  red	N-36 6084  red	N-37 C 6225  dark blue
N-61 951  white	N-77 C 6207 	N-78 D 393  black	N-15 C 6195  orange MM	N-17 D 6174 	N-73 CY 813  red MM	N-501 C	

Tonar replacement types for: **TRIO**

N-6 AT 296 white	N-11 758 yellow	N-15 0 MK II 803 white	NF-15 0 MK II 802 red	N-20 780 white	N-23 445 grey	N-25 654 1. grey	N-26 771 black
N-30 654 1. grey	N-31 655 black	N-32; N-33 571 white	N-34 541 white	N-35 686 brown/ silver	N-36 656 dark grey	N-37 657 red	N-38 325 scarlet
N-39 326 orange	N-39 MK II 958 black	N-39 MK III 829 black	N-40 323 4-channel	N-41 677 yellow	N-42 323 ES 4-channel	N-43 658 blue	N-44 688 ES 4-channel
N-45 1493 MC	N-46 755 black	N-47 730 white	N-48 758 yellow	N-49 764 orange	N-50 908 black	N-51 E 908 DE DE	N-52 6008 blue
N-53/V-53 876 black	N-54 6021 blue	N-55 1408 MC blue	N-56; N-56 B 935 black	N-57 1407 green/black	N-58 6139 IM black	N-59 6138 MM dark grey	N-77 6353 grey
N-61 6204 MM blue	N-62; V-62 6183 red blue	N-63 6158 blue	N-64 393 black	N-64 C 393 DE black	N-65 6249 green	N-66 6257 MM red	N-67 6258 MM red
N-68 6283 MM blue	N-69 6259 MM red	N-70 1586 grey	N-71 6291 black	N-72 6335 1. blue	N-73 6204 purple/blue	N-74 6334 black	N-75 957 black





 Tonar replacement types for: **TRIO TRACK**

		AC-100	AC-1				
72 red	390 white	239 	239 				















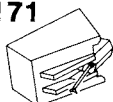
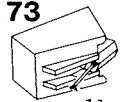
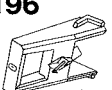
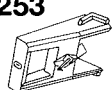
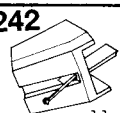
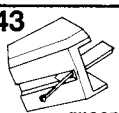
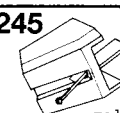

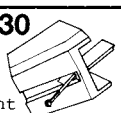
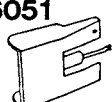
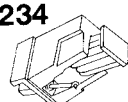
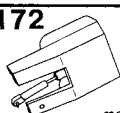
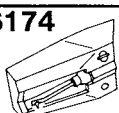
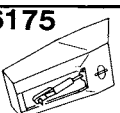
 Tonar replacement types for: **UHER**

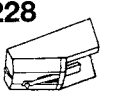
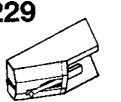
					L-4	Q-4	MMD-345
956 red	832 red	973 white	6016 blue	974 yellow	1251 blue	1401 blue	2474 black

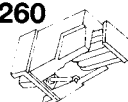
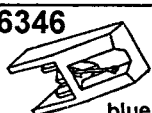

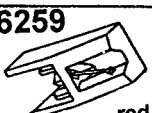
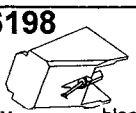

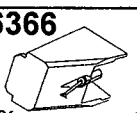

Tonar replacement types for: **UNITRA**

MF-100	MF-102	UF-70		MF-101			
622  white	622  white	6262  red	311  white	622			



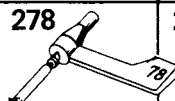
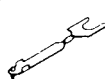

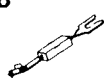
Tonar replacement types for: **U.P.O. 'S**

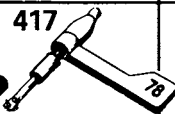
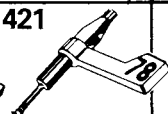
CN-108			KP-20				
6241  IM orange	6239  MM blue	6164  MM red	6133  white	6171  IM	6173  MM yellow	6196  MM black	6253  IM grey
6242  MM yellow	6243  MM green	6245  MM gold	6240  IM violet	6016  light blue	6130  light green	6051  white	6234  IM red
6172  red	6174  red	6175  red	6259  MM red	6228  MM red	6229  IM black	6258  MM red	6260  MM
CN-229	MG-2721	CN-234	CN-111	CN-246; CN-252	CN-254	CN-251	
6346  blue	6353  grey	6259  red	6198  IM black	6353  grey	6366  MM black	6365  yellow	

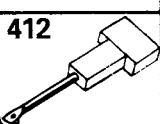

Tonar replacement types for: **VACO/LUXOR**

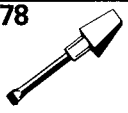
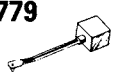
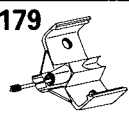
M 50	MS 8; SN 45	S 45	SN-65-75	ST 20/40; ST 100	ST 20/40	STP 2	T 45
226 	227 	224 	278 	27 	223 	148  stereo	225 
TN-02H	TN-04	TN-8					
279 	417 	421 					

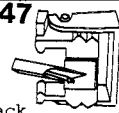

Tonar replacement types for: **VALKONA**

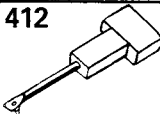
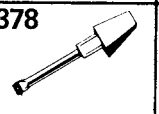
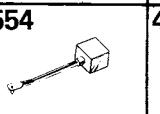
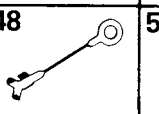
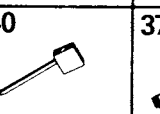
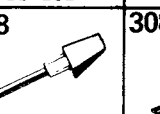
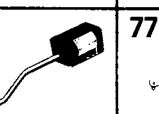
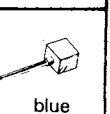
KD-69	CS-21; KS-23	KSS-0162	KSS-0163	CN-24	MS-16	KS-231	MS-27 D
412 	554 	540 	378 	779  blue	1179 	779 	1247  black

Tonar replacement types for: V.E.B.

KD-69 412 	KS-22 378 	CS-21; KS-23 554 	KSMU-0261 448 	KSS-0162 540 	KSS-0163 DS-262 378 	MS-8 308 	CN-24 779  blue
KS-231 779 	MS-27 D 1247  black						

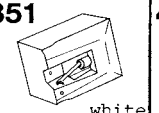
Tonar replacement types for: VISONIK

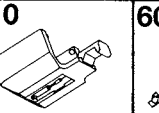
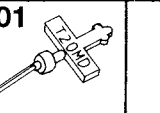
YM-818 6130  green				T-20 MS 851  white			
	456  white	910 	6001 				

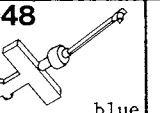

Tonar replacement types for: WALTHAM

T-30 MS 948  blue							
--	--	--	--	--	--	--	--

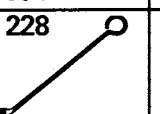
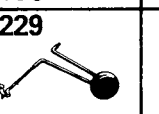
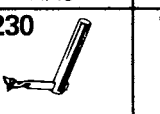
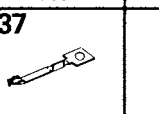
Tonar replacement types for: WEBSTER ELECTRIC

SC 1 228 	SC 3 229 	WE 14/15 230 	WE 57/58 137 				
---	---	---	---	--	--	--	--

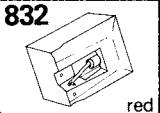
Tonar replacement types for: WEGA

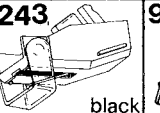
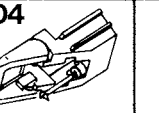
832  red	ATN-70 795  red	MCN-42 1243  black	ND-139 G 904 				
--	--	---	---	--	--	--	--



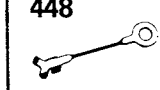



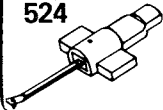
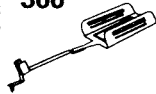

Tonar replacement types for: WEHKAMP

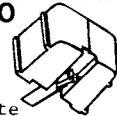
KSMU-0261 448 							
--	--	--	--	--	--	--	--

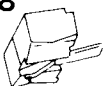

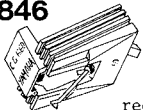
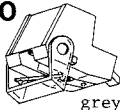
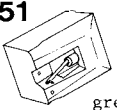
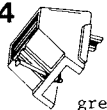

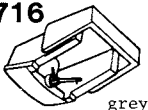
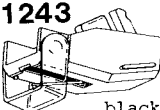
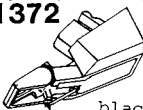
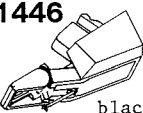
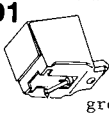
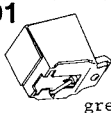
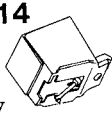
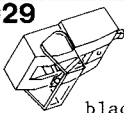
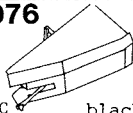
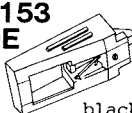
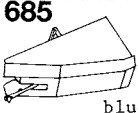
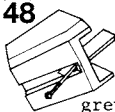
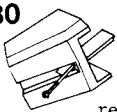
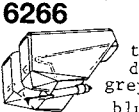

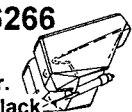
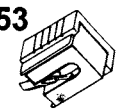



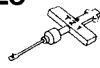

Tonar replacement types for: **WILSON**

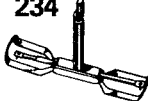
524 	366 						
---	---	--	--	--	--	--	--

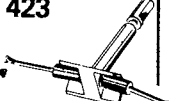
Tonar replacement types for: **YAMAHA**

MC-101	N-3000	N-3500 N-4000	N-4500; N-4500 MK II	N-5000	N-5500	N-6000	N-6500
NO LONGER AVAILABLE	296 	690 	785 	398 	542 	NO LONGER AVAILABLE	571 
MC	MM white	white	black	grey	white	NO LONGER AVAILABLE	white
N-6600	N-6600 S	N-6700	N-6800	N-6900	N-7000	N-7030	N-7050; M-705 MC
846 	850 	851 	864 	6113 	716 	1243 	1372 
red	grey	grey	grey	dark grey	grey	black	black
N-7080; MC-708	CG-7700	N-7800	N-7900	N-8000	N-8010; MC-801	N-8100	N-8200
1446 	991 	991 	6114 DE 	929 	976 	6153 DE 	1685 
black	grey	grey	tr. ruby	black	MC black	black	blue
N-102	N-103	CG-8300 N-8300	N-8400	AL-E 500	N-2500		
6148 	980 	6266 	6289 	6266 	6853 		
grey	red	tr. dk. grey/blue	tr. blue	tr. black			

Tonar replacement types for: **ZENITH**

142-185	142-76/77	142-80	142-90	142-126/128	142-136/141	142-150	142-167
6128 	233 	104 	103 	234 	235 	268 	423 
blue	brown LP/78	blue	red				
S-15222	S-15780	S-11473	14271	14272	14273		
1986 	1988 DA 	1990 DN 	232 DS 	232 DA 	232 DN 		
green	allplay green/red	red 78 rpm	blue	yellow allplay	purple 78 rpm		

IMPORTANT!

On the following pages you will find a listing of the most important crystal, ceramic and magnetic cartridges in our line. Almost all of these cartridges have special attachments and cannot be replaced by other cartridges. Most cartridges with a universal 1/2 inch screw mounting have not been listed as these can economically be replaced by the Tonar models, which are listed in the first part of our catalogue. In the case you require a model, which is not listed on these pages, please contact the importer in your country as in most cases we will be able to supply the one you are looking for.

Tonar replacement types for: A.D.C.

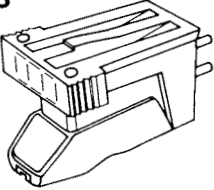
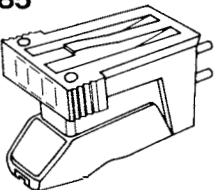
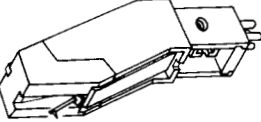
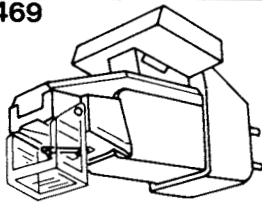
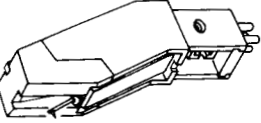
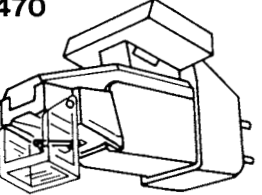
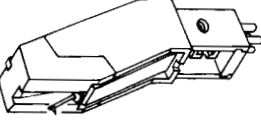
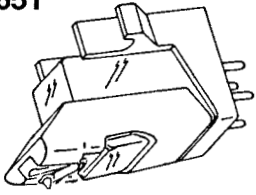
QLM-30 MK III B Slidemount bracket 2453 	QLM-32 MK III B Slidemount bracket 2485 	L-3 2466 	Q-3 2469 
L-4 2467 	Q-4 2470 	L-5 2468 	QLM-30 MK3 2651 

Tonar replacement types for: AUDIO TECHNICA

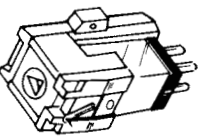
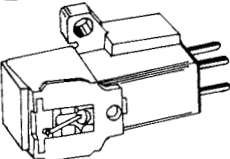
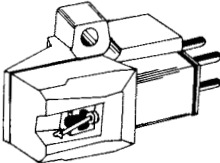
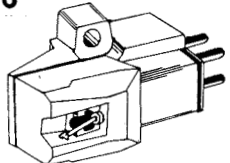
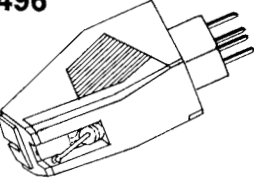
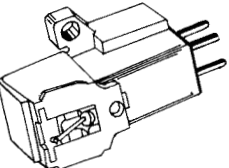
AT-71 2648 	AT-91 2392 	AT-3400 2492 	AT-95E; AT-3451 E 2806 
AT-3482 PB 9496 	AT-3600 L 2491 		

Tonar replacement types for: BANG & OLUFSEN

MMC-1 9355 	MMC-2 9357 	MMC-3 9359 	MMC-4 9334
MMC-5 9334 	MMC-10 E REPLACED BY MMC-20 S 9248 	MMC-20 S 9248 	MMC-20 E 9248
MMC-20 EN 9363 	MMC-20 CL 9365 		

Tonar replacement types for: B.S.R.

X-5 H 2009 	X-5 M 2010 	SC-5 H 2012 	SX-6 M 2014
SX-6 H 2140 	SC-7 M-2 2382 	SC-7 M-4 2153 	TC-8 S 2007
TC-8 H 2008 	SC-11 M 2165 	SC-12 M 2016 	SC-12 H 2271

Tonar replacement types for: **CONER**

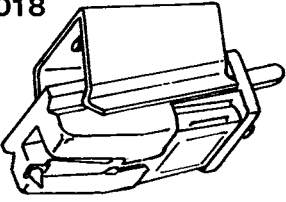
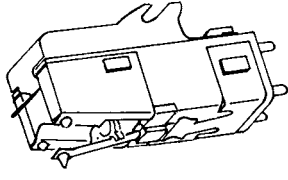
RCQ-mono	RCS-stereo		
2018 	2017 		

 Tonar replacement types for: **COSMO**

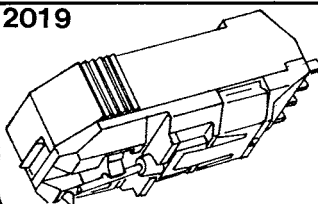
TC-0014			
2019 			



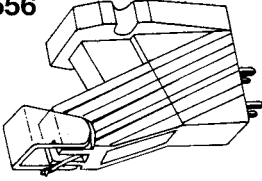
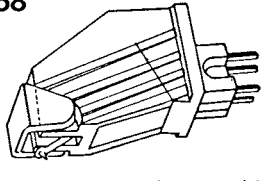
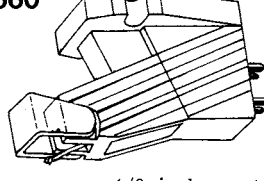
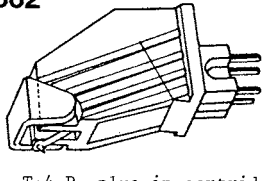

 Tonar replacement types for: **DIGITRACK**

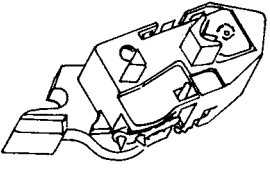
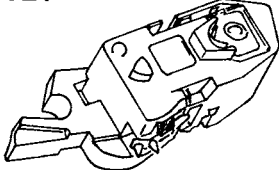
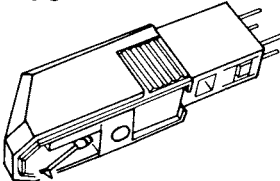
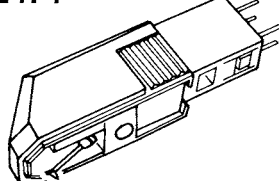
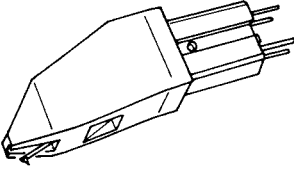
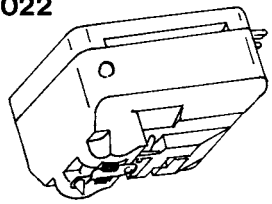
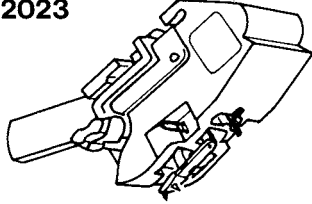
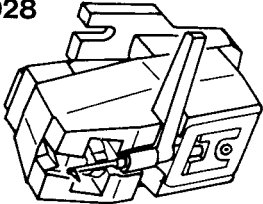
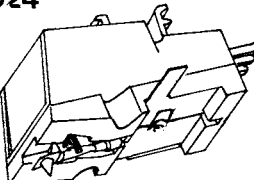
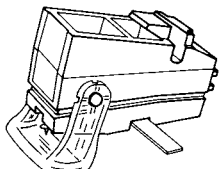
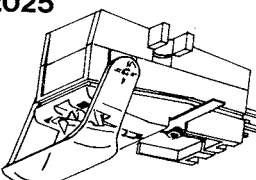
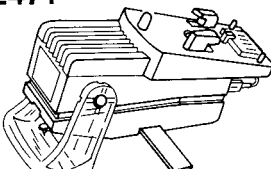
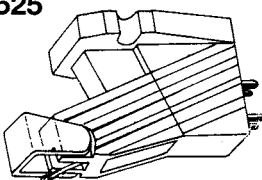
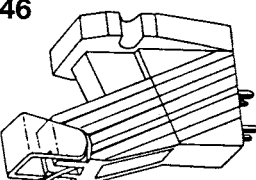
25 S	25 SP	50 E	50 EP
2656  1/2 inch mounting	2658  T-4 P plug-in cartridge	2660  1/2 inch mounting	2662  T-4 P plug-in cartridge

Tonar replacement types for: **DUAL**

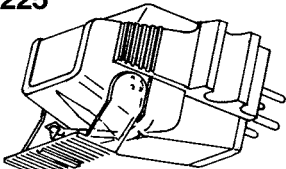
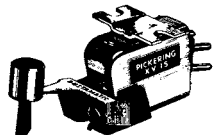
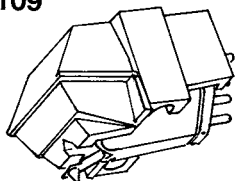
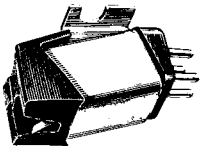
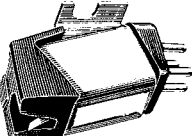
CDS-3/34 2020 	CDS-320/3 2021 	MMD-340 2473 	MMD-345 2474 
MMD-360 E 2475 	CDS-420/43 2022 	CDS-520 2023 	CDS-630 2028 
CDS-660 2024 	CDS-670 2327 	CDS-671 2025 	TKS-670 2471 
DMS-245 2525 	DMS-249 2646 		

 Tonar replacement types for: **DJ CARTRIDGES**

NAGAOKA JT-511 DJ 2225 	PICKERING XV-15 625 DJ 2294 	SHURE SC-35 C 2109 	STANTON 500 AL 2126 
STANTON 500 EL 2695 	STANTON 680 AL 2548 	STANTON 680 EL 2353 	STANTON 680 SL 2347 

Tonar replacement types for: **ELAC**

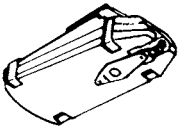
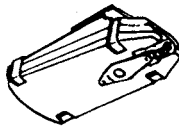
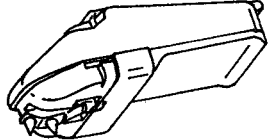
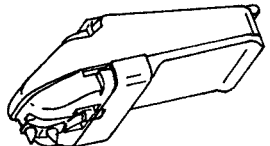
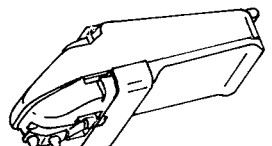
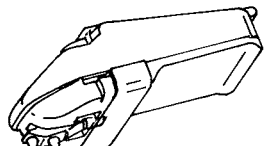
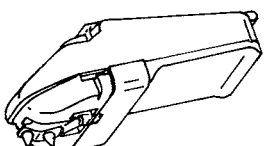
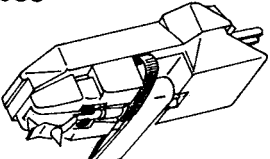
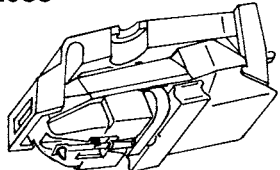
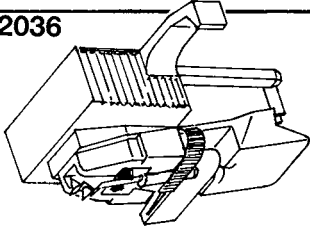
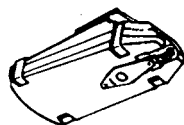
KST-5 2696	KST-9; KST-19 2030 	KST-11 2697 	KST-12 2698 
KST-22 2699 	KST-102 2031 	KST-103 2700 	KST-104 2032 
KST-106 2033 	KST-109 2701	KST-110 D 2035 	KST-112 2036 
KST-115 2610	KST-21 9385 		

Tonar replacement types for: **FONICA**

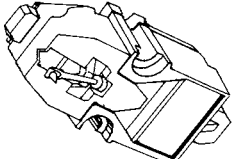
UF-70 2552 			
---	--	--	--

Tonar replacement types for: **GENERAL**

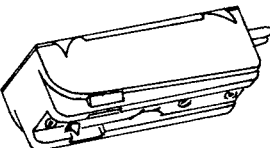
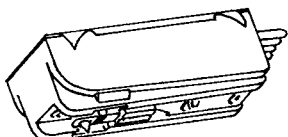
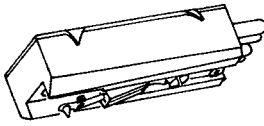
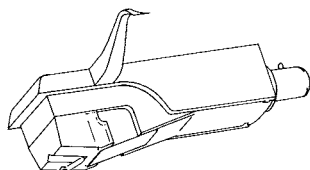
MC-110 2219 	SC-110 2221 	NX-600 2220 	C-712-01 IN SME SHELL 2258 
--	--	---	--

Tonar replacement types for: **JAPAN COLUMBIA**

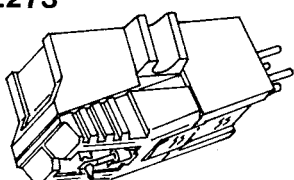
JL-23; JC-23 2273 			
--	--	--	--

Tonar replacement types for: JUKEBOX TYPES (see also SCHUMANN types)

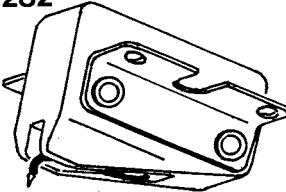
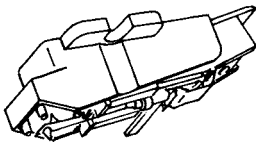
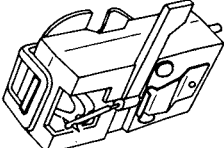
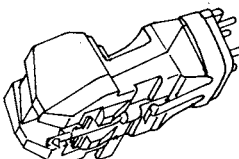
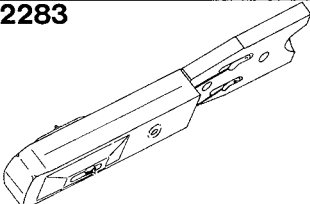
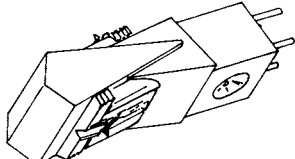
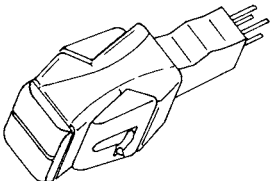
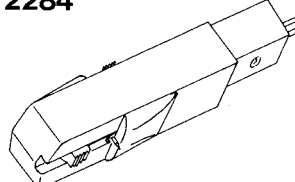
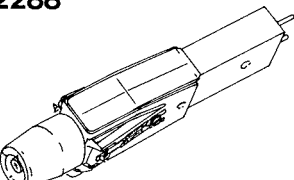
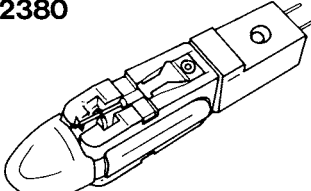
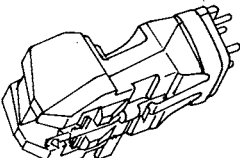
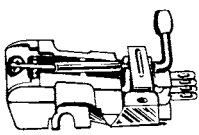
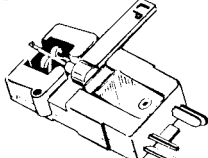
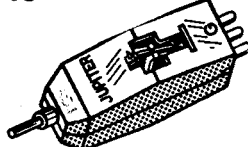
ASTATIC 51-1 M	ASTATIC STEREO	ASTATIC 146 (15 D)	ASTATIC 133 DD (N-51 D)
2282 	2287 	2333 	2346 
Seeburg 631238; A-251620 Pickering black	Seeburg Stereo 249755 Pickering	Seeburg Showcase 253781	Seeburg 246796-(2) Pickering
2283 	2285 	2286 	2284 
Seeburg Conversion Cartridge models "B" through "201"	Seeburg Conversion Cartridge models "B" through "201"	Wurlitzer 138662	ASTATIC/SONOTONE
2288 	2380 	2346 	2620 
	SONOTONE 31 TA	TEPPAZ JUPITER FOR JUPIMATIC JUKEBOX	ZENITH COBRA
2623	2340 	2713 	2624

Tonar replacement types for: LESA

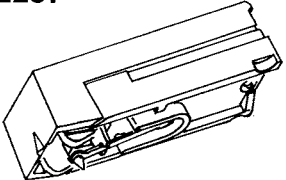
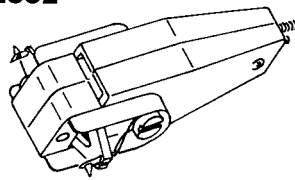
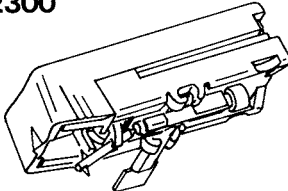
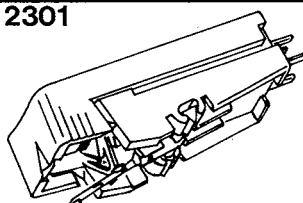
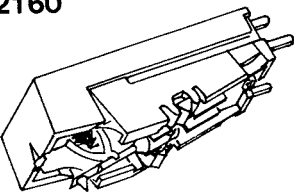
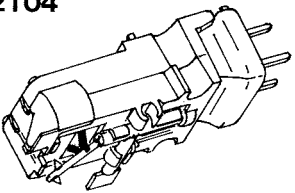
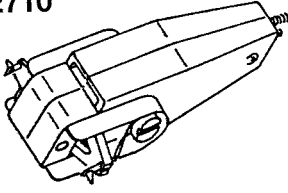
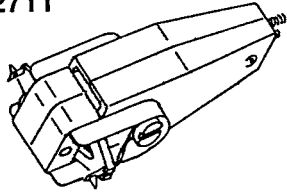
C-1	E-3	F	K-2
2257 	2302 	2300 	2301 
K-3	W	E-2	E-4
2160 	2104 	2710 	2711 

Tonar replacement types for: **NATIONAL**

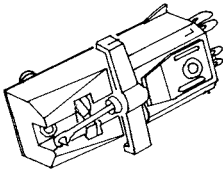
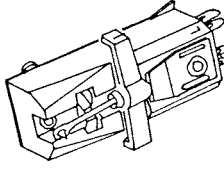
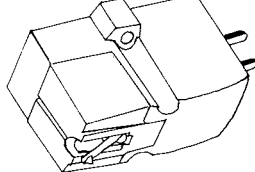
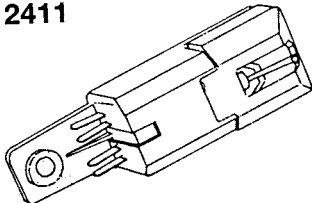
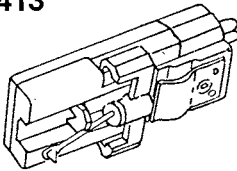
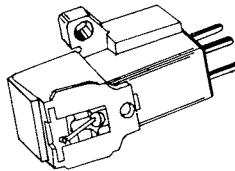
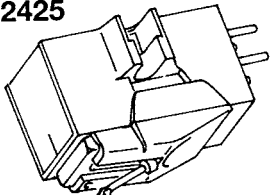
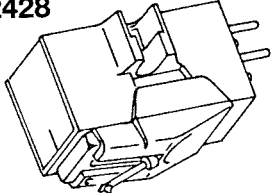
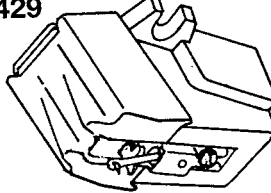
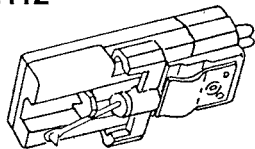
EPC-02 STH	EPC-05 STA	EPC-05 STAD	EPC-09 STAD
2404	2408 	2409 	2410 
EPC-13 STH	EPC-34 TTCD	EPC-34 STCD	EPC-36 SMAD
2411 	2414	2413 	2415 
EPC-36 SMBD	EPC-42 STAD	EPC-69 STLD	EPC-69 STA
2416	2417	2438	2418
EPC- 74 SMAD	EPC-76 SMAD	EPC-77 SMAD	EPC-78 SMAD
2420	2423	2424	2425 
EPC-79 SMAD	EPC-82 SMAD	EPC-95 SSED	EPC-34 STBD
2427	2428 	2429 	2412 
EPC-451 C			
2434			

Tonar replacement types for: **NIVICO**

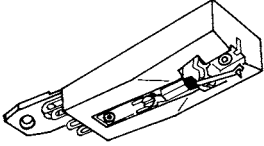
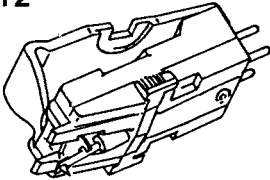
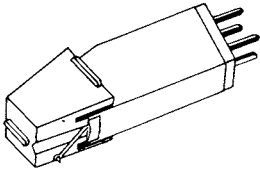
CS-1021 H	DT-51	DT-36	MD-1041 Z
2361 	2512 	2531	2541 

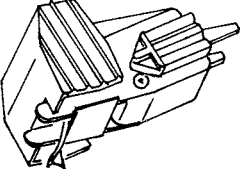
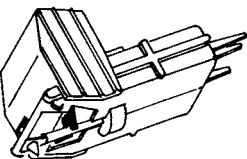
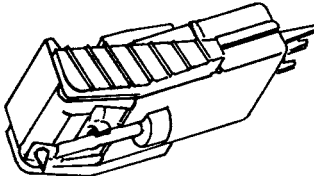
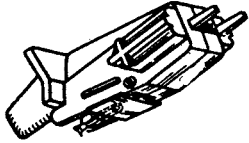
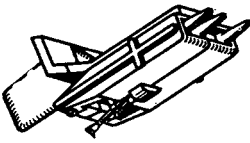
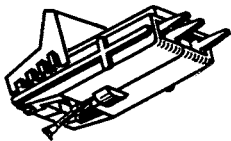

 Tonar replacement types for: **PATHE MARCONI**

MUCS/MCS - MONO	STUCS/STC-S STEREO	STC-41 STEREO	MUCS/MCS - MONO RED GRIP
2052 	2053 	2200 	9492 RED GRIP 
STUCS/STC-S STEREO	STC-10 S STEREO		
9498 RED GRIP 	9325 		

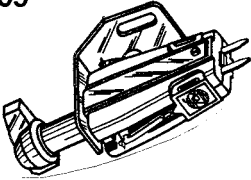
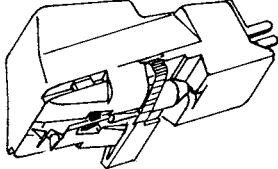
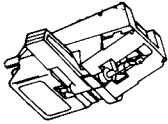
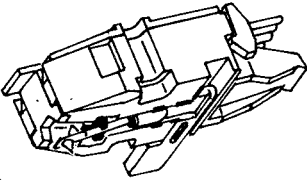
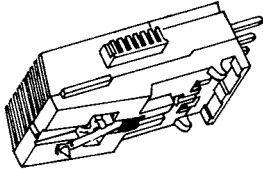
 Tonar replacement types for: **PERPETUUM EBNER**

PE-30	PE-30/2	PE-188	PE-190
2709 	2708	2054 	2055 
PE-192	PE-194	PE-7000	
2095 	2056 	2707	

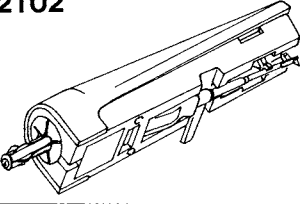
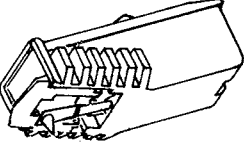
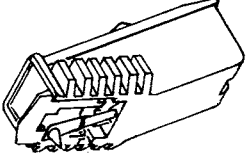
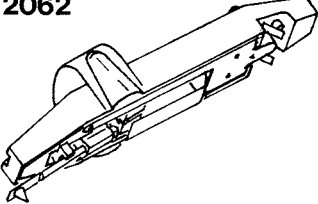
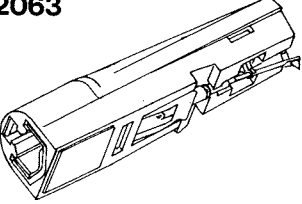
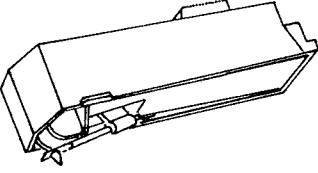
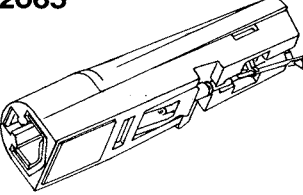
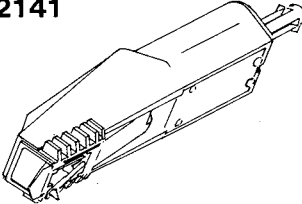
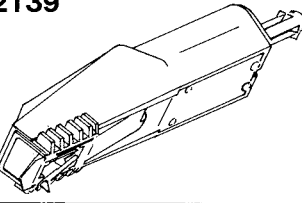
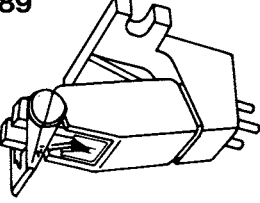
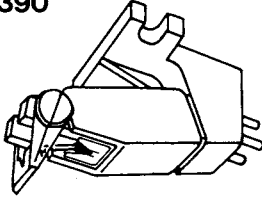
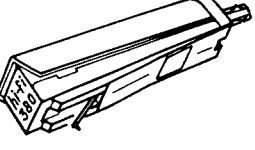
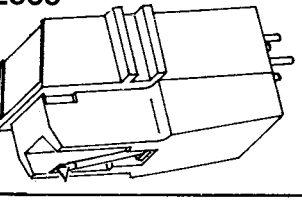
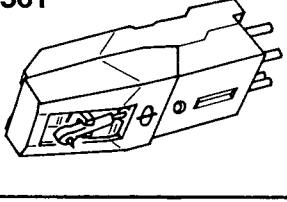
Tonar replacement types for: PHILIPS

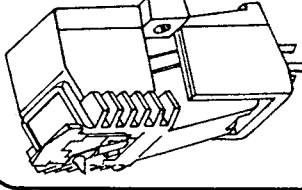
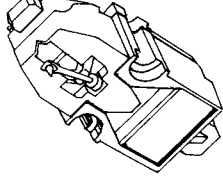
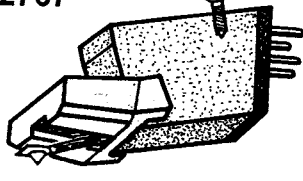
GP-200;GP-300 GP-204;GP-205 2102 	GP-214 2061 	GP-215 2132 	GP-229 2062 
GP-230 2063 	GP-231 2064 	GP-235 2065 	GP-314 2141 
GP-315 2139 	GP-330 2389 	GP-331 2390 	GP-380 2393 
GP-390 2066 	GP-397 MK III 2322	4822 251 30095 2561 	GP-330 integrated 2564 
GP-814 2148 	UF-70 2552 	MG-2510 2767 	4822 251 30112 2795

Tonar replacement types for: RIGONDA

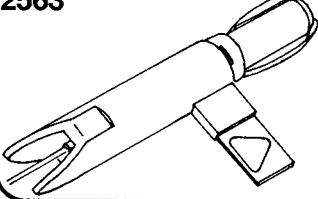
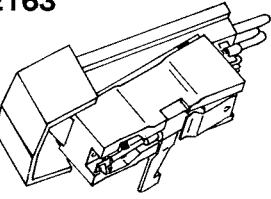
ACCORD MONO 2563 	COMIX 2163 	RIGONDA	
---	---	---------	--

Tonar replacement types for: **RONETTE**

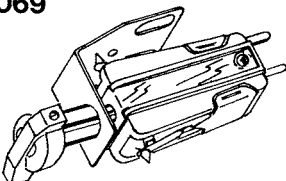
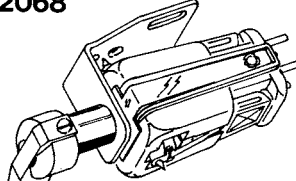
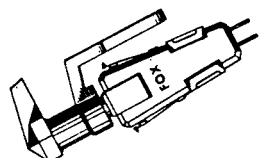
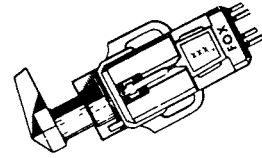
DC-284 OV	ST-105	DC-284 MONO CRYSTAL	ST-105 STEREO CERAMIC
2069 	2068 	9510 	9342 

Tonar replacement types for: **SANYO**

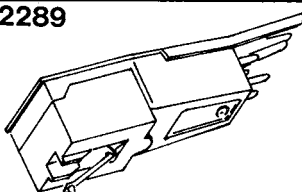
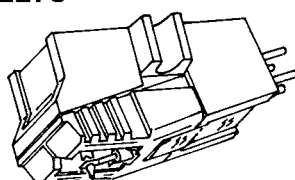
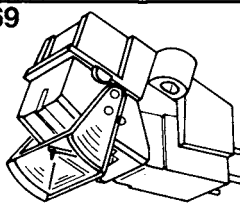
MGT-5	MGT-17	ST-15 J	
2289 	2273 	2369 	

Tonar replacement types for: **SCHUMANN**

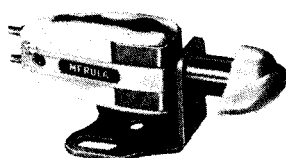
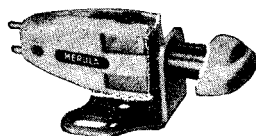
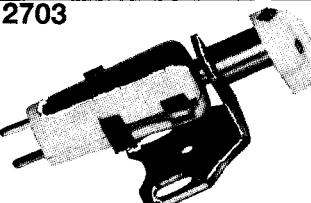
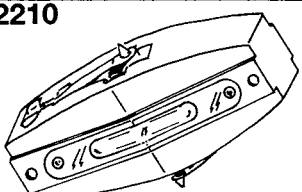
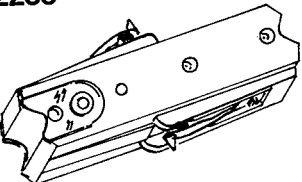
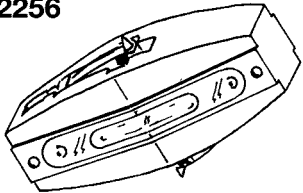
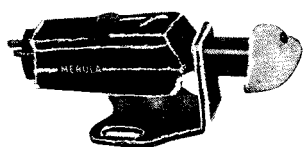
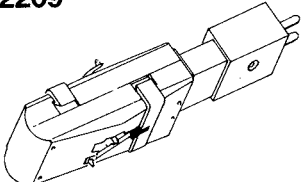
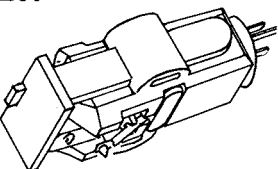
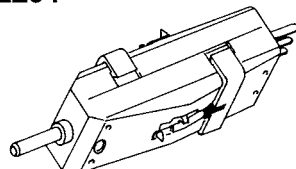
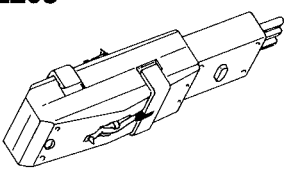
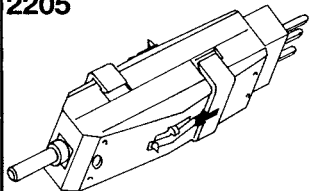
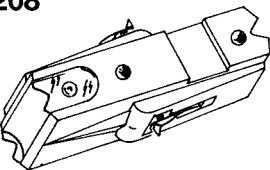
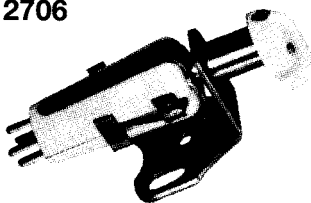
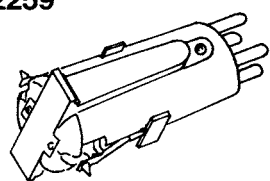
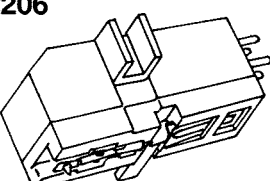
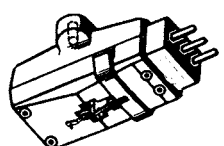
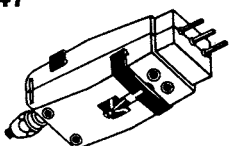
SK-451 A	SK-458 A	SK-459	SK-460
2712 	2702 	2703 	2210 
SK-461	SK-463	SK-474	STC-476
2255 	2256 	2704 	2209 
STC-480/2	STC-485	STC-486	STC-487
2207 	2204 	2203 	2205 
STC-492	SK-495	SK-496	STC-496/1
2208 	2705	2706 	2259 
STC-500		STC-485; STC-487	
2206 	2846 	2847 	

Tonar replacement types for: SHARP

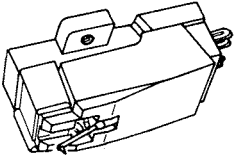
STY-717			
2388 			

Tonar replacement types for: SONOTONE

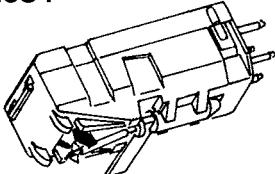
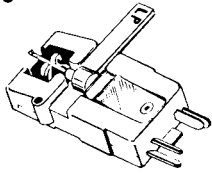
3509	31 TA		
2084 	2340 		

Tonar replacement types for: SONY

XL-200	VX-24 P	VL-30 G	
2650	2617	2615	

Tonar replacement types for: SUPRAPHON

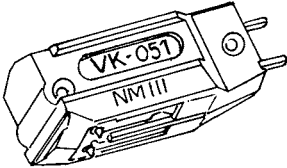
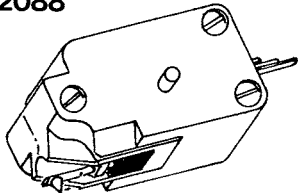
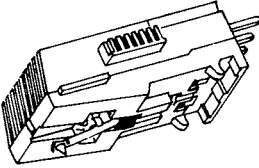
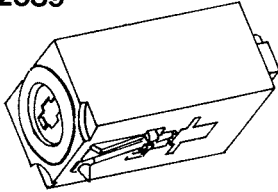
VK-051	VK-311	VM-2101	VM-2102
2090 	2088 	2091	2608
VK-4302	KS-22	VM-2103	VM-2204
2056 	2089 	2774	2775

Tonar replacement types for: TELEFUNKEN

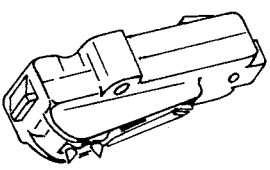
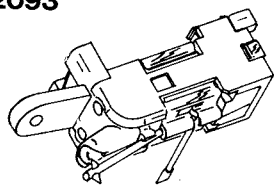
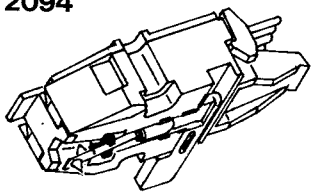
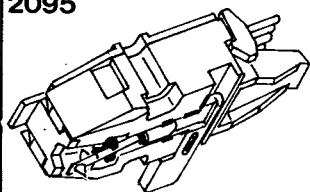
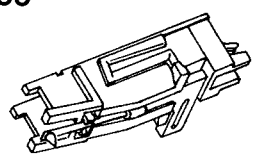
T.T.S.A. 2092 	T-22-2 2093 	T-25-2 2094 	T-25-2 COPY 2095 
T-260/1 E 2096 			

Tonar replacement types for: TEPPAZ

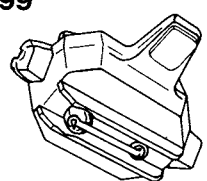
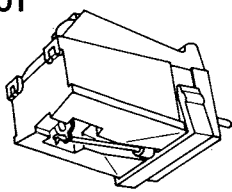
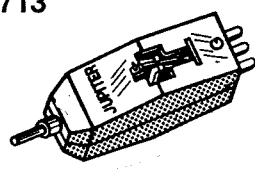
VISSEAU MONO 2099 	STEREO 60 2100	MT-30 2101 	JUPITER 2713 
---	--------------------------	---	--

Tonar replacement types for: TETRAD

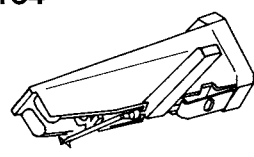
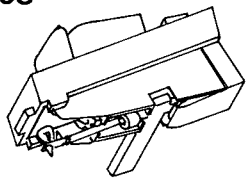
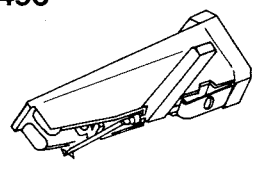
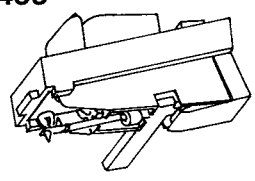
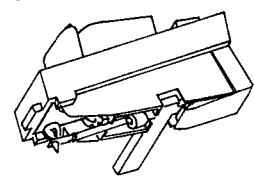
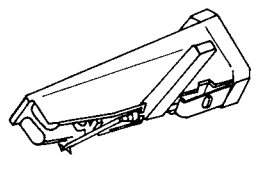
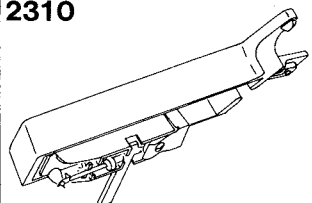
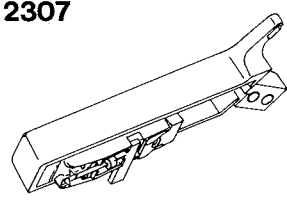
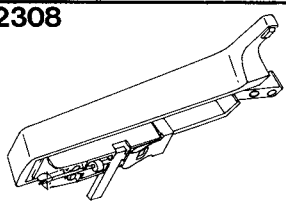
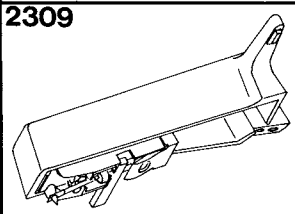
TC-8 HO 2154 	TC-8 HI 2498 	TC-11 MO 2496 	TC-11 MI 2499 
TC-12 MI 2497 	TC-12 MO 2381 	GL-93 2310 	97 2307 
V-122 2308 	V-142 2309 	TC-12 HI 2547	TC-12 HO 2551

Tonar replacement types for: TOSHIBA

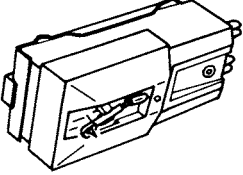
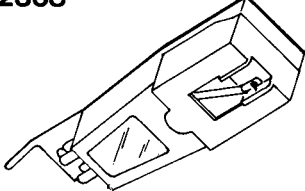
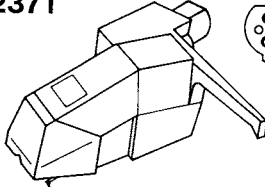
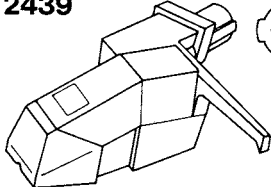
C-20 C	C-22 C	C-62 M	C-63 M
2370 	2368 	2371 	2439 

Tonar replacement types for: U.P.O. 'S

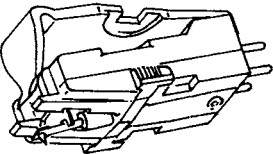
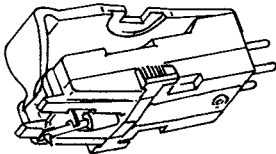
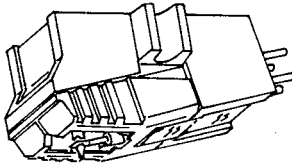
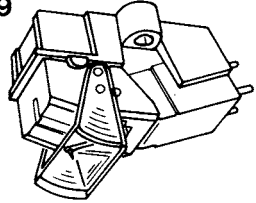
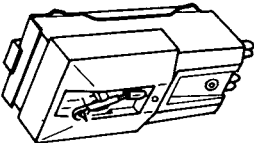
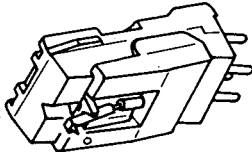
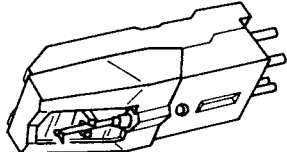
CZ-680-6C	CZ-680-9	CZ-682	CZ-693
2272 	2512 	2273 	2369 
CZ-698-3	CZ-699		
2370 	2514	2513 	2515 

Tonar replacement types for: VALKONA

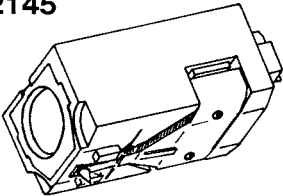
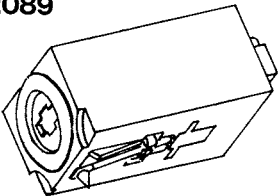
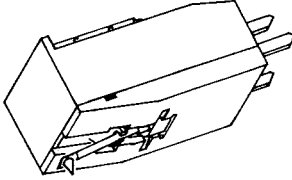
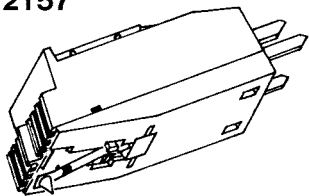
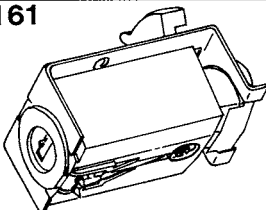
MS-16	KS-22 KSS-0163	KS-23	CS-24
2145 	2089 	2097 	2157 
KSMU-0161	KSMU-0263	CS-24/CS-29	
2162	2161 	2157	

Tonar replacement types for: ZENITH

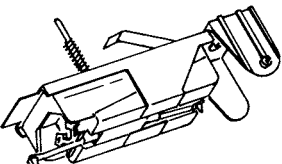
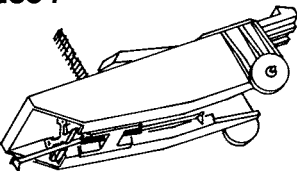
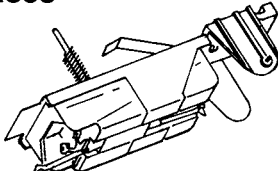
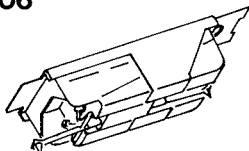
142-166	142-167	142-168	142-182
2303 	2304 	2305 	2306 

Tonar replacement types for: A.D.C.

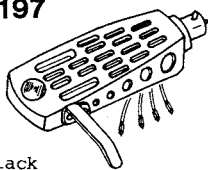
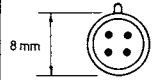
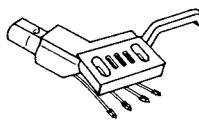
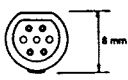
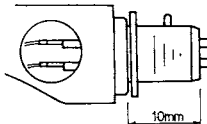
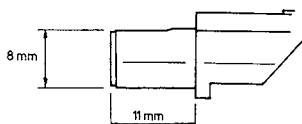
A.D.C. 1500		<u>C-114864</u> for recordplayers: A.D.C. 1600; A.D.C. 1700.			
3197  black	 8 mm back view 1:1	3146 	 8 mm back view 1:1		
 10 mm 8 mm side view 1:1		 8 mm 11 mm side view 1:1			

Tonar replacement types for: BANG & OLUFSEN

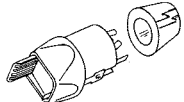
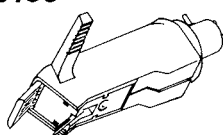
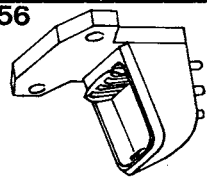
ADAPTER FOR MOUNTING MMC-20 SERIES CARTRIDGES ONTO SP-SERIES TONEARM		ADAPTOR FOR MOUNTING MMC-20 SERIES CARTRIDGES ONTO SME-TYPE TONEARM		ADAPTOR FOR MOUNTING MMC-20 SERIES CARTRIDGES IN UNIVERSAL HEADSHELLS WITH R.E.T.M.A. 1/2 INCH SCREW ATTACHMENTS	
3090 		3150 		3156 	

Tonar replacement types for: B.S.R.

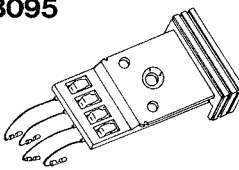
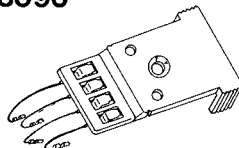
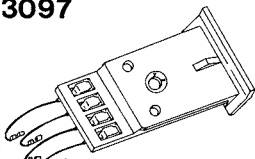
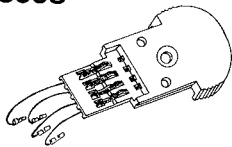
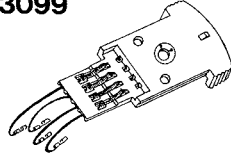
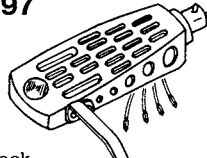
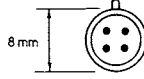
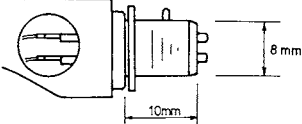

<u>A-108693</u> for recordplayers: MP-60; 510; 610.		<u>A-111497</u> for recordplayers: BDS-80; P-157		<u>A-111875</u> for recordplayers: BDS-90; P-161	
3095 		3096 		3097 	
no longer available niet meer leverbaar				no longer available niet meer leverbaar	
A-112016		A-113696		<u>A-114990</u> (SME) for recordplayers: 500 Quanta; 600 Quanta; 800 Quanta	
3098 		3099 		3197  black	 8 mm back view 1:1
				 10 mm 8 mm side view 1:1	

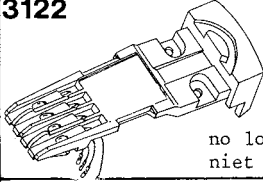
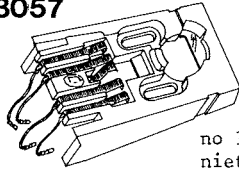
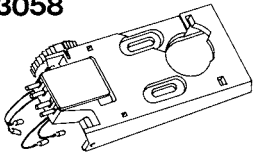
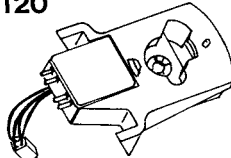
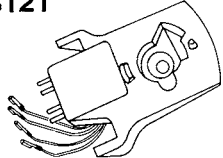
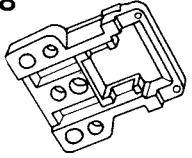
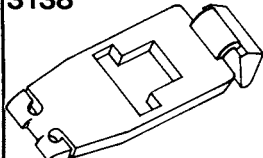
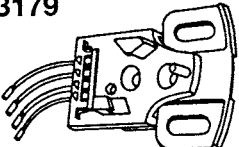
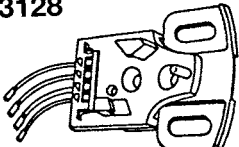
Tonar replacement types for: **DUAL**

0-12 B		TK-12		TK-14; TK-24 for record players: 1209-49; 461; 481; 491, 502; 504; 510; 521; 601; 604; 621; 701; 704; 714; 721; 731.	
3122		no longer available niet meer leverbaar		3057	
				no longer available niet meer leverbaar	
TK-25 for recordplayers: 1209-49; 461; 481; 491; 502; 504; 510; 521; 601; 604; 621; 701; 704; 714; 721; 731.		TK-26 for record players: 714 Q; 731 Q.		TK-27 for recordplayers: 714 Q MC; 731 Q MC.	
3058		3120		3121	
TKS-236;TKS-237 TO: R.E.T.M.A.		HS-421;427;430		K 261865	
3148		3138		3145	
G 262186		TKS-G 266048		TKS 269611	
3178		3179		3128	
CONTINUED					

Tonar replacement types for: DUAL

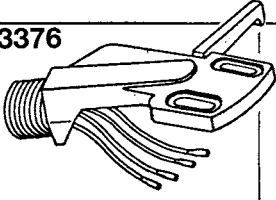
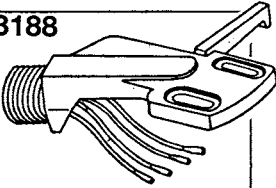
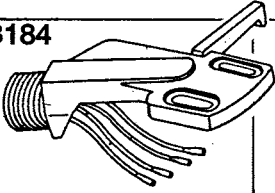
CONTINUED

269654 (TKS-49 S)		275361	277955	
3127		3376 	3188 	
277956		VTA 279606	280112	
3184 	3302 		3301 	

Tonar replacement types for: Lenco

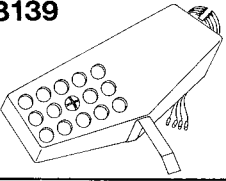
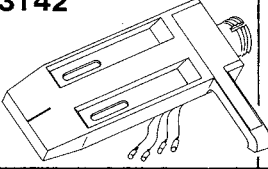
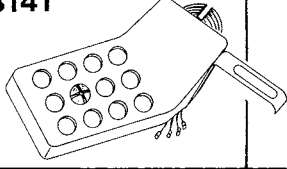
B-52; B-55; L-75; L-78		L-60; L-62; L-65; L-80; L-84; L-130; L-133; L-236; L-247; L-332; L-744	L-85; L-90; L-830; L-833	
3139 	3142 		3141 	

Tonar replacement types for: NATIONAL (PANASONIC, TECHNICS)

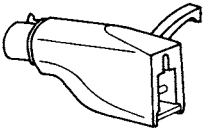
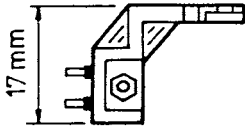
SH-80 S ADAPTOR T-4 P to SME		ADAPTOR T-4 P to: ½ - inch screw-mount			
3163	 back view 1:1	3125	 side view 1:1		

Tonar replacement types for: PERPETUUM EBNER

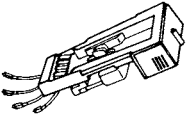
3010; 3012; 3015					
3175					

Tonar replacement types for: PHILIPS

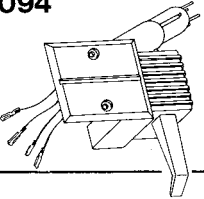
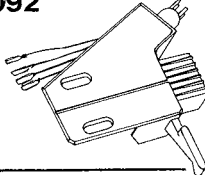
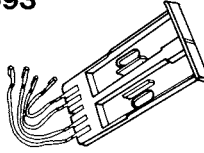
4822 265 30145		4822 402 60627		4822 444 30169	
3094		3092		3093	

Tonar replacement types for: PIONEER

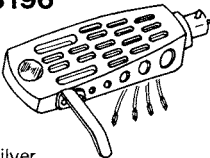
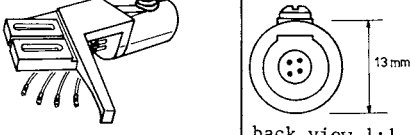
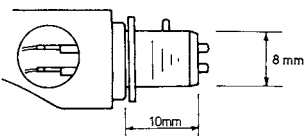
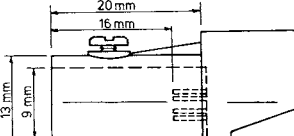
SME-type "S" - arm		PXB-563 straight-arm			
3196	 silver back view 1:1	3129	 back view 1:1		
 side view 1:1	 side view 1:1				

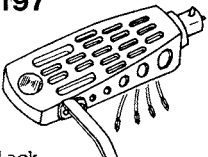
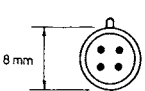
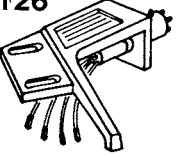
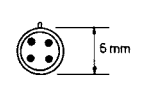
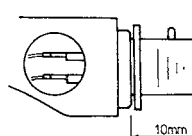
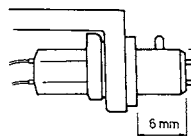

Tonar replacement types for: **SONY**

		SH-151			
3197		8 mm 	3126		6 mm 
black	back view 1:1		back view 1:1		
	8 mm 10 mm side view 1:1		6 mm 6 mm side view 1:1		

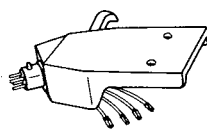
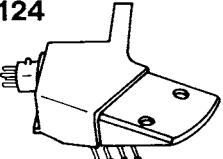
 Tonar replacement types for: **SUPRAPHON**

HC-16; NC-160; NZC-160 SL-160; NZK-160		NC-420; NZC-420; NZC-421; L-452; L-500		HC-43; L-43 CH; NC-430; L-430; NZC-431; NC-435; L-435; NC-450; L-450	
3123		3124		3409	
	8AK 425002.01		8AK 425000		7AK 42530.03
HC-30; NC-300; NZC-300 L-300; SL-301					
3160					
	8AK 425.005.01				

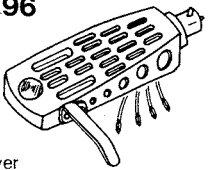
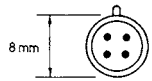
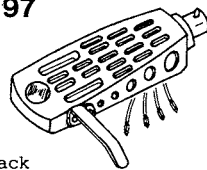
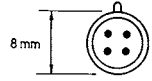
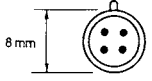
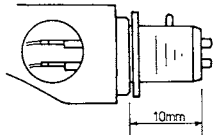
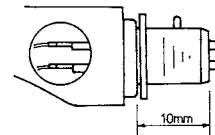
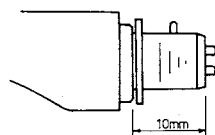
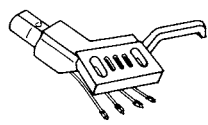
Tonar replacement types for: **TONAR**

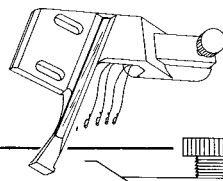
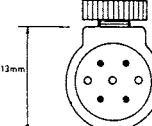
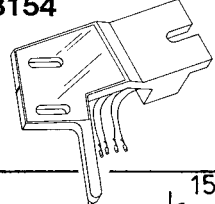
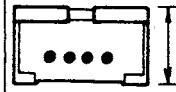
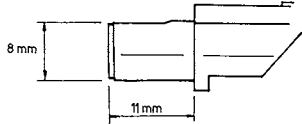
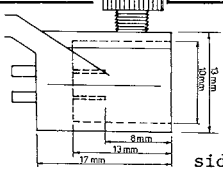
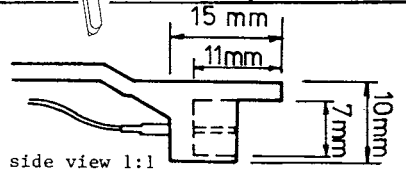
UNIVERSAL SHELL "S" ARM S.M.E. TYPE		UNIVERSAL SHELL "S" ARM S.M.E. TYPE		SLIM-LINE S.M.E. type	
3196  silver	 8 mm back view 1:1	3197  black	 8 mm back view 1:1	3147	 8 mm back view 1:1
 8 mm 10 mm side view 1:1	 8 mm 10 mm side view 1:1	 8 mm 10 mm side view 1:1			
UNIVERSAL SHELL STRAIGHT ARM ADC-type					
3146 	 8 mm back view 1:1	3155 	 13 mm back view 1:1	3154 	 10 mm back view 1:1
 8 mm 11 mm side view 1:1	 8 mm 13 mm 17 mm 37 mm side view 1:1	 15 mm 11 mm 7 mm 10 mm side view 1:1			



TONAR No.	May be used as replacement for:
1	Acos GP-59
2	Acos GP-37
3	Acos GP-29
4	Acos GP-73/1;73/3
5	Acos GP-65; GP-67
6	Acos GP-71/3
7	Acos GP-33
8	Acos GP-19
9	Acos GP-81
10	Admiral 409 B 19-8 Shure PC-42
11	Philips AG-3010; 3012; 3013; 3015; AG-3025; 3026; 3109; 3113; 3114
12	Philips AG-3016; GP-316
13	Philips AG-3001
14	Philips AG-3063; 3066; 3304; 3308 (this needle is used on the stereo side of these cartridges.)
15	Philips AG-3301; 3302; 3304; 3305 (this needle is used on the 78-RPM side of these cartridges.)
16	Philips AG-3020; 3021; 3027; 5012; 5013
17	Philips AG-3052; 5001
18	Philips AG-3201; 3202; 3221; 3222
19	Philips AG-3400; 3410; 3401; 3402
20	Philips AG-3306; 3310; 3224; 3228; AG-3230; AU-1010; 1020; 1030 GP-200; GP-224; 228; 230; 235; 300; 306; 310 Tonar 5-pole (type II)
21	Philips AG-3201 (D)
22	Astatic N-34; Q
23	Astatic N-39; A
24	Astatic N-29; G
25	Astatic N-36; L; T
26	Astatic N-31; K
27	Astatic N-7; Columbia CS-520 Nagaoka NC-100; 202; 203; 500; 400; NC-400 H Piezo MS-2; MST-13 Ronette TO-284-OE Supraphon VK-051 Tonar NC-100; NC-505 This needle is also used on the 78-RPM side of the following cartridges: Tonar NC-202; NC-203; NC-400 NC-40 NC-400H; Vaco/Varco ST-20/40 ST-100 Toshiba TP-102; 106; 114
28	Astatic N-8
29	Astatic N-30; 55; GCD
30	Astatic N-38; 57; GC
31	Astatic N-41; N-42; 17-D
32	Astatic N-50; 51; 133
33	Astatic N-43; 15-D
34	Astatic N-45; 45-D
35	Astatic 13 T
36	Astatic N-37; U
37	Astatic 81-T
38	Astatic N-60
39	Astatic N-52; N-53
40	Astatic N-54; N-55
41	Astatic N-56
42	Bang & Olufsen B & O
43	Bang & Olufsen professional
44	Bang & Olufsen 350 R; 72
45	Bang & Olufsen SP-1; SP-2 Perpetuum Ebner PE-9000 Dual DN-301; 302; SP-1
46	B.S.R. TC-8
47	B.S.R. TC-8 stereo
48	B.S.R. TC-4
49	B.S.R. TC-12
50	B.S.R. ST-3; ST-4 Piezo Y-565; 575; 590 Sanyo ST-3 D
51	B.S.R. ST-5; ST-6; ST-7
52	Collaro PX
53	Collaro studio
54	Columbia SC-1
55	Decca XMS
56	Decca H
57	Dual CDS-1
58	Dual CDS 2/3

TONAR No.	May be used as replacement for:
59	Dual DN-1
60	Dual DN-3
61	Dual DN-4
62	Dual DN-24
63	Dual DN-26; DN-45
64	Dual DN-32
65	Dual DN-34
66	Dual DN-23; DN-43
67	Dual DN-90; DN-95; DN-96
68	Eden old model
69	Eden 59
70	Eden stereo
71	Eden 62
72	Eden clarville Novak clarville Trio Track
73	Elac SNM-9; SMM-9 Perpetuum Ebner PE 8/10
74	Elac SN-12 Perpetuum Ebner PE-5
75	Elac KST-2
76	Elac SNM-100 Perpetuum Ebner PE-180 US
77	Elac SM-101
78	Elac SNM-102 Perpetuum Ebner PE-184 US
79	Elac SM-103
80	Elac SNM-104 Perpetuum Ebner PE-182 US
81	Elac SNM-14
82	Elac SM-107; SM-110
83	Elac STS-210 Perpetuum Ebner PE-8000
84	Elac SNM-106; DMSN-112; SNM-406 Perpetuum Ebner PE-186
85	Elac STS-310
86	Elac SNM-402
87	Elac MST-2
88	Electronic Reproducers ER-60
89	Electronic Reproducers ER 5 MX
90	Electronic Reproducers ER 5 SB
91	Electro Voice 10; 14; 34; 4130
92	Electro Voice 16; 16TT
93	Electro Voice 21
94	Electro Voice 26
95	Electro Voice 31; 2606
96	Electro Voice 57; 2610
97	Electro Voice 58; 2611
98	Electro Voice 37; 72; 2614
99	Electro Voice 117; 131; 148; 2616
100	Electro Voice 122 to 125
101	Electro Voice 132; 141; 149; 2617
102	Electro Voice 147; 2621
103	Electro Voice 51 Zenith 142-90
104	Electro Voice 56 Zenith 142-80
105	Astatic 91-T Electro Voice 76 Webcor A-1919
106	E.M.I. multiplay
107	E.M.I. RS-3
108	Euphonics E-1
109	Euphonics U-1; J-13 HC
110	Euphonics U-8/9
111	Euphonics U-10/11
112	Euphonics U-12/13
113	Garrard GC-2
114	Garrard TOM-1
115	Garrard TOM-2
116	Garrard GC-8
117	Garrard GCS-10
118	Garrard GC-12
119	General Electric RPX-040
120	General Electric RPX-047; 050 (complete)
121	General Electric RPJ-047 plug in
122	General Electric VR-II/G-15 only (complete)
123	General Electric VR-II plug in
124	General Electric GC-7
125	General Electric VR-22

TONAR No.	May be used as replacement for:
126	General Electric C-100
127	General Electric C-200
128	General Electric VR-1000-7
129	General Electric C-500
130	Goldring 500
131	Goldring 200
132	Goldring 580; 600
133	Goldring MX 1/2
134	Goldring CS-90; CS-91 E
135	Goldring CM-60; CS-80
136	Goldring 700
137	Lenco single Lesla D Philco 35-2775 Ronette TO-284 Webster Electric WE-57-58
138	Lenco double
139	Lesla A
140	Lesla B
141	Lesla E
142	Lesla U
143	Lesla U-2
144	Lesla S
145	Luxor 72411
146	Luxor 72786
147	Luxor 74916
148	This needle is used on the stereo side of the following cartridges: Europhon Hitachi DS-ST-2; DS-ST-9 Japan Colombia (Denon) DSN-1; SJN-1 Luxor 65977 Mitsubishi 3D-20 M; ST-15; SP-16 Nagaoka NC-202; 203; 400; 400 H Neat N-100 Piezo SC-503 Tonar NC-202; NC-203; NC-400 H Vaco STP-2 etc., etc.
149	Magnavox 560151; 560133
150	Magnavox 560101
151	Magnavox 560161
152	Merula STK-490 Schumann STK-490
153	Merula SC-474 Schumann SC-474
154	Pathé Marconi 51
155	Pathé Marconi 53
156	Pathé Marconi RC 5/6
157	Pathé Marconi STC-7; STC-S STC-41 Pathé Marconi STC-2000 D Saba Disco Centre STC-10 S Thompson STC-100 D; STC-1000 D
158	Pathé Marconi stereo
159	Perpetuum Ebner PE-12
160	Perpetuum Ebner PE-188
161	Perpetuum Ebner 7000
162	Perpetuum Ebner PE TO 48/51
163	Philco 45-9612
164	Philco 35-2682
165	Philco 325-8214 Sonotone 3-T Telefunken 3 TS
166	Pickering 150 Seeburg R-150
167	Pickering 150 plus spring
168	Pickering stereo Seeburg mark II
169	Piezo SMT-29
170	Piezo MS-8
171	R.C.A. 74068
172	R.C.A. 75497
173	R.C.A. 104; 200; 108800
174	R.C.A. 110020; 110022
175	R.C.A. 115060
176	R.C.A. 115061
177	Radiohm Mono; Stereo
178	Reson 33; 78
179	Reuter N-4; S-1
180	Ronette BF-40 Perpetuum Ebner 30/90 Sonotone 14-T Iskra
181	Ronette TX-88



TONAR No.	May be used as replacement for:
182	Merula Fanfare
	Schumann Fanfare
183	Merula SK-451
	Schumann SK-451
184	Merula SK-452
	Schumann SK-452
185	Merula SK-453
	Schumann SK-453
186	Merula SK-456; STK-494
	Schumann SK-456; STK-494
187	Seeburg stereo
188	Seeburg juke box
189	Shure P-72; W-68
190	Shure PC-9; WC-38
191	Shure PC-6; WC-6
192	Shure ML-44; PC-2
193	Shure PC-12; WC-32
194	Shure M-3-D
195	Shure M-21-D
196	Shure PC-20; WC-20
197	Shure M-77
198	Sonotone 1-P
199	Sonotone 3-P
200	Sonotone 8-T; 8-TA; 8-TA-77
	Telefunken 8-TS
	Magnavox 560247
201	Sonotone 9-T
202	Sonotone 12-T
203	Sonotone 12-T-LA
204	Sonotone 12-T-HR
205	Sonotone 16-T
206	Sonotone 916-T new and improved Universal needle for the following series: 9T; 9TA; 9TAF; 9TAFV; 9TAV; 9TV; 16T; 16TA; 16TAF; 916T; 916TA; 916TAF
207	Sonotone 20-T
208	Sonotone 21-T; 22-T; 23-T
209	Sonotone 26-T; 27-T
210	Stare
211	Electronic Reproducers ER 5 MX 1
	Sanyo STG-3
212	Lesla K-2
213	Tannoy MK II
214	Teppaz Visseau
215	Teppaz Stereo
216	Telefunken TTSA
217	Telefunken A-20-1; T-20-1
218	Telefunken A-20-2; T-20-2; T-22-2
219	Telefunken A-200; T-200
220	Tetrad 11; 31; 111
221	Tetrad 21; 41; 121; E-1; G-1
222	Tonar NM-11-A
	Nagaoka NM-11-A
223	Vaco ST-20/40 (stereo only)
224	Vaco S-45
225	Vaco T-45
226	Vaco M-50
227	Vaco SN-45; MS-8
228	Webster Electric SC-1
229	Webster Electric SC-3
230	Webster Electric WE-14/15
231	Zenith 15780; 15222; 11473
232	Zenith 142-71; 142-72; 142-73; 142-74
233	Zenith 142-76/77
234	Zenith 142-126/128
235	Zenith 142-136/141
236	Dual DN-22
237	Electro Voice 169; 2622
238	Philips AG-3019
239	Schumann/Merula STK-495/1
	Trio Track AC-100
240	Pathé Marconi MUCS; MCS
241	Ronette TA-600
242	Shure M-33-5
243	Shure M-33-7
244	Sonotone 18-T
245	Shure M-7-D
246	Acoss GP-91
247	Philips AG-3306-1 (short handle)
248	Astatic N-64
249	Empire Scientific 88
250	Empire Scientific 108; 108 P

TONAR No.	May be used as replacement for:
251	Empire Scientific 880 P; 880 PE
252	Conver stereo
	COSMO "cosmo"
253	Dual DN-5; 52; 54; 55; 56
	Dual CDS-630/5
254	Electro Voice 194; 2623
255	Electro Voice 198/199; 2624
256	Euphonics U-15/16
257	Lesla W
258	Sonotone 2T
	Philco 325-8210
	Telefunken 2-TS
259	Perpetuum Ebner PE-92
260	R.C.A. 115276; 115302; 115303
261	R.C.A. 100020 A
262	Sonotone 25-T; 28-T
263	Nagaoka NM-22
	Tonar NM-22
264	Tetrad 12; 32
265	Tetrad 13; 33
266	Tetrad 52; 62; A-2; B-2; C-2
267-5	Shure M-44-5
267-7	Shure M-44-7
	Dual DN-305; DN-306; M-44 M-G
268	Zenith 142-150
269	National EPS-05; EPS-05 ST
	N.E.C. LP-5 D; SP-5 S
	Onkyo DN-3 ST
	Sansui ST-3
270	Mastercraft SJN-1
	Tonar/Nagaoka NC-770
	Piezo Y-310; Y-730
271	Sonotone 9-TA (flexible)
272	Singer 484001/5; PU-1300
	Japan Columbia JTS-3
273	R.C.A. 117330/118197
274-DE	Shure M-55-E
275	Pickering V-15-6 mil
	Dual DN-314; 315; V-15 PD/1
276	Jensen 409 C; 64-1
277	Magnavox 560305
278	Vaco SN-65; CN-60/62/67/68
	Mono
	Vaco CN-70; 72/75 (stereo)
279	Vaco TN-02-H
280	Philips AG-3311; GP-311 Philitina
281	Tetrad 50; 60; A-0; B-0; C-0
282	Ortofon N-15 S; N-15 O; F-15 S; F-15
283	Tetrad 22; 42; E-2; G-2
284	Shure M-8-D
285	B.S.R. ST-10
286	B.S.R. ST-9; ST-8
287	Electro Voice 47; 2614; 2615
288	Euphonics U-17/19
289	Astatic N-74
290	Astatic N-76
291-DE	Ortofon N-15 E; F-15 E; N-15 EO; F-15 EO
292	Teppaz Eco 60/432; 26
293	Neufunk
	Tetrad 23; 43; E-3; G-3
294-DE	Hitachi DS-ST 70; DS-ST-72
295	Tetrad 10; 30
296	Audio Technica AT-6
	Hitachi DS-ST-3; MFS-170/171
	Japan Columbia (Denon) DSN-10/13
	Kenwood N-6 AT
	Marlux NM-33
	Nagaoka NM-33
	N.E.C. LP-20 D
	Nivico DT-16
	Onkyo DN-5; DN-13
	Pioneer PL-N6
	Sansui ST-6 D; SN-22
	Sanyo ST-12 D; MG-3
	Sharp N-05 D; N-06 S
	Sony ND-113 P; VM-9 P
	Tonar NH-33
	Toshiba N-4 CS; C-07
	Trio N-6 AT
	Yamaha N-3000
297	R.C.A. 106969; 106770; 106771
298	R.C.A. 115329
299	Telefunken A-23-2; T-23-2; A-25-2
	T-25-2

TONAR No.	May be used as replacement for:
299	Fonica UF-50
300	General Electric C-650
301	Philips AG-3404; 3407; 3408; 3409; GP-404; 407; 408; 409; 410; 411
302	Sonotone 100-T
303	Magnavox 560344/45
304	Sonotone 32-T; 39-T
305	R.C.A. 118199; 118200
306	Allphon 66
307	Acoss GP-79
308	V.E.B. MS-8
309	Lenco M-200
310	Lesla F-5
311	Telefunken A-23/1
312	Astatic N-79
313	Astatic N-81
314	Astatic N-83
315	Bang & Olufsen SP-6/7 Stylus only
315-DE	Bang & Olufsen SP-8/9 Stylus only
316	Sony ND-128 P; VX-24 P
317	Magnavox 560348
318	Tetrad 14; 34
319	Tetrad 20; 40; E-0; G-0
320	C.E.C. MG-8;
	Pioneer PN-15
321	Tetrad 24; 44; E-4; G-4
322	Setton
	Sharp STY-213; STY-703
323-ES	Akai APN-4
	Kenwood N-40; N-42
	Sony ND-130 G
	Trio N-40; N-42
324	Pioneer PN-12; PN-110
325	Kenwood N-38
	Trio N-38
326	Kenwood N-39
	Trio N-39
327	Tetrad 51; 61; A-1; B-1; C-1
328	Tetrad 53; 63; A-3; B-3; C-3
329	Tetrad 54; 64; A-4; B-4; C-4
330	Tetrad 70; 80; 90
331	Empire Scientific 909/X; 999/X
332	Empire Scientific 90EE/X; 909 E/X; 999 E/X
333	Empire Scientific 1000 ZE; 1000 ZE/X
334	Coral 555-5
335	Tetrad 71; 81; 91
336	Tetrad 72; 82; 92
337	Tetrad 73; 83; 93
338	Tetrad 74; 84; 94
339	Acoss Power Point
340	Bang & Olufsen SP-6/7 Complete needle
340-DE	Bang & Olufsen SP-8/9 Complete needle
341	Elac DM-240
342	Electro Voice 5000
343	Electro Voice 37; 38; 47; 72; 2626
	Jensen J-2T
344	Lesla F-3
345	Empire Scientific 888
346-DE	Empire Scientific 999/VE
347	Nivico DTS-1
348	Nivico DTS-2; ST-17
	Sharp N-08 D
349	Japan Columbia JTS-1/5; DTS-1/5
	Singer PU-1357
350	Radiohm CM-71
351	Goldring SX-10
352	Goldring G-800
353	Acoss GP-91-1 SC; 2 SC; 3 SC
354	Astatic N-72
355	Astatic N-85
356	Perpetuum Ebner PE-223/1
357	Perpetuum Ebner PE-192; PE-223/2
358	Connoisseur SCU-1
359	Micro SC-301; New Yorker
360	Shure M-44-C
361	A.D.C. 770
362	Pickering U-38/380 D-3807 AT
363	Nagaoka NR-1
	Tonar NR-1



TONAR No.	May be used as replacement for:
364	Acos GP-93/94
365	Empire Scientific 808
365-DE	Empire Scientific 80 EE; 808 E
366	Coner RCQ mono Wilson
367	Onkyo DN-8 ST; SN-20 ST Piezo Y-640 N.E.C. LP-25 D Sanyo ST-6; ST-6-D; MGT-1 Lesa K-3 new version
368	Neufunk
369	Allphon PC-1
370	Piezo Y-100; Y-510
371	Japan Columbia (Denon) DSN-35
372	National EPS-13; 13 TT; 13 TTSD Henfai Sharp N-09 D Toshiba N-550 C; C-550 M
373	Europhon
374	Intel National EPS-14 ST; 14 STSD Onkyo DN-12 ST
375	Audak R-2/R-6
376	National EPS-37
377	Acos GP-95/96
378	Olympic 1 Supraphon KS-22 Valkona KSS-0163 V.E.B. KSS-0163; KS-22; DS-262
379	Rion NP-01 D
380	Piezo 03-40729
381	Nivico VPF-96 Singer PU-3012
382	Blaupunkt 305 M N.E.C. LP-305 M Sanyo ST-37 D
383	Astatic N-35; "R"
384	Marantz CT-300; TT-320; TT-130; TT-221; CTS-420 Schneider
385-DE	Shure M-75-E
386	Dual DN-320; 323 Shure M-73 M-G; 75 E; 75 M-G
387	Dual DN-325 Luxor 3823 Schneider DN-325 Shure M-75 6; M-75 6 S; M-75 D; Shure M-75 M-G; M-71 MB-D; M-71; Shure M-73 M-G; M-75 M-G
388	Nivico DT-45
388-DE	Nivico DT-45 E
389	Neat VS-700; V-70; VS-90
390	H.M.V. HMV-1 Merula HMV-1 Schumann/HMV-1 short handle; Trio Track
391	H.M.V. HMV-2 Merula HMV-2; STC-481 Schumann STC-481; Schumann/HMV-2
392	Acos GP-104
393	Marantz TT-143; TT-243 Sanyo STP-50J Scott Sharp STY-129; 133; 139;
393-DE	Yamaha N-8100
394	Conver B-60-100 Cosmos G.62.30.M.23
395	Pioneer PL-N9
396	Pioneer PN-10; PN-11
397	National EPS-08; P0; 10 STDD; 12 N.E.C. LP-10 D Onkyo DN-7; DN-10; DN-17 Audio Technica AT-21; AT-66
398	Onkyo DN-15 ST Sharp N-17 D Toshiba N-12 C; C-26 M Yamaha N-5000
399	Coral V-30-D; V-7000 Micro M-207 Mitsubishi 3D-23 M; 3D-24 M Sansui ST-10; SN-23
400	Micro V-3100 Mitsubishi 3D-28 M
401	Dual M-91 MGD; DN-330

TONAR No.	May be used as replacement for:
401	Shure M-91-G
402	National EPS-19 STSD
403	Seeburg "Showcase"
404	Allphon 69-1 single tip
405	Philips AG-3229; GP-229 (spring only)
405-C	As above complete with ceramic element
406	Sanyo ST-51 J Siemens
407	Electro Voice 2630; 5015
408	Electro Voice 2634; 5051
409	Euphonics U-8 RB/U-9 RB
410	Euphonics U-10 RB/U-11 RB
411	Euphonics U-15/2
412	K.D.-69, also for K.S.M.U., V.E.B. & Valkona
413	R.C.A. 120695; 122057
414	Schumann/Merula STC-485/486 Jupimatic jukebox Sonotone 21/24-TA
415	Sonotone 60-T
416	Vaco TN-04
417	Electro Voice 2632; 5018
418	R.C.A. 126566/7
419	Schumann/Merula STC-480
420	Vaco TN-08
421	A.D.C. 220; A.D.C. R-20
422	Zenith 142-167
423	B.S.R. ST-12/14/15
424	Schneider ST-12/14/15
425	Allphon Jeunesse
426	Hitachi HN-ST-20; CFS-280 Mitsubishi ST-11; 3D-32 M National EPS-22 Nivico DT-20
427	Elac STS-244-C; D-244 C
428	Elac STS-244-17; D-244-17
429	Elac STS-344; D-344
430	Elac STS-444; D-444
431	Electro Voice 2637; 5076
432	Electro Voice 2638; 5081
433	Electro Voice 2639; 5082
434	Electro Voice 2640; 5078
435	Garrard GCM-31; GCS-1; 35; 36 Sonotone 2109; 2509; 2539
436	Garrard GCM-21-22; GKM-22 Goldring HC-2 Rigonda 2163 Tonar 5-pole
437	Garrard GCS-23; GKS-25/26 Goldring HC-3
438	Garrard GCM-21 T/22 T GCS-23 T; TS-1/2/3
439	Perpetuum Ebner PE-190
440	Ronette SC-107; SC-109
441	Ronette CMT-102
442	B.S.R. ST-16/17 Fidelity Schneider ST-16/17
443	Dual CDS-650; 651; 660; 661 Dual CDS-670; CDS-671 Dual DN-6; 8; 62; 63; 64; 65; 85 Perpetuum Ebner PE-3000; CDS-650; CDS-651
444	Clean CM-500 Hape Piezo Y-930; YM-101
445	Kenwood N-23 Trio N-23
446	Teppaz MT-30
447	Nagaoka/Tonar NM-66
448	K.S.M.U.-0261, also for Wehkamp & V.E.B. Piezo stereo
449	Supraphon VK-311; 68317
450	National EPS-24 STSD
451	Hitachi HN-ST-19
452	Mitsubishi SJN-16 Teleton CMS-500/400/300 Japan Columbia DSN-16; SJN-16 Nagaoka/Tonar NM-33 A
453	Contra SN-20
454	Acos GP-104 transcription
455	Audio Sonic
456	

TONAR No.	May be used as replacement for:
456	N.E.C. LP-40 D Sanyo ST-14 D; MGT-5 Sharp STY-704 Toshiba N-11 C; SN-280; 290 Visonik
457	Lustre L-1
458-DE	Sony ND-70 X; XL-70
459	Electro Voice 2636; 5080
460	Electro Voice 2641; 5083
461	General Electric C-660
462	Garrard KS-40 A Schneider KS-40 A Sonotone 3509
463	Goldring G-850 Lenco M-95
463-DE	Goldring G-850 E
464	Perpetuum Ebner PE-194 Supraphon VK-4302
465	Dual DN-311; V-15 D/AC Luxor 3200 Pickering V-15/D-1507 AT; V-15 P/AT
465-DE	Pickering V-15/D-1500 ATE; V-15 P/ATE
466	R.C.A. 131779/131780
467	R.C.A. 131781/131788 (single tip)
468	Grado B-series ceramic
469-DE	Shure M-91-E
470	Astatic N-89; 205
471	Tetrad C-0
472	Shure M-92-G
473	Nivico DTZ LIS
474-DE	Shure M-92-E (old)
475	Japan Columbia (Denon) DSN-55
476	Goldring G-800 H
477	Ortofon D-15 E Super
478	Ortofon D-15 Super
479	Astatic N-17; 207
480	Astatic N-19; 223
481	Tetrad A-1
482	Tetrad A-2
483	Tetrad A-3
484	Tetrad C-1
485	Tetrad C-2
486	Tetrad C-3
487	Tetrad E-1
488	Tetrad E-2
489	Tetrad E-3
490	Tetrad G-1
491	Tetrad G-2
492	Tetrad G-3
493	Schumann/Merula STC 487
494	Nagaoka/Tonar NC-700
495	Astatic N-14; 215
496	Sony ND-126 G; VM-26 GH
497	Sony VX-17-P; VX-18-P; ND-119-P; ND-120-P
498	Sony ND-117-P; VM-15 P
499	Japan Columbia DSN-24; GN-20 Onkyo DN-18 ST Sony ND-124-P; ND-125-G; VM-21-G; VM-21-P
500-DE	Shure M-93-E
501	Pickering V-15/D-1507 AC; V-15 P/AC
501-DE	Pickering V-15/D-1500 ACE; V-15 P/ACE
502	Grace F-8; F-21 series
503	Philips GP-370
504	Dual DN-70; CDS-700
505	Sony ND-121 P; VM-19 P
506	Osaka Onkyo DN-21; OC-21 M Piezo Y-995
507	Osaka Onkyo DN-22; OC 22 M
508	Toshiba N-301-C; C-301-F; N-04 C; C-04 C
509-DE	Nivico DT-33 S
509-ES	Hitachi F-11; MT-11 F Nivico 4 DT-1X; 4 DT-5X; 4 DT-10X
510	Nivico DT-11; SS-11
511	Philips GP-400; GP-500
511-DE	Philips GP-401
512	Lesa C-1 Vaiani VA-62



TONAR No.	May be used as replacement for:
513	Sansui SN-10; SN-10 A
514	Sanyo MG-2; ST-5 D
515	National 28-100 ST
516	National EPS-25; 25 STSD
517-DE	Shure N-75-EJ type II
518	Shure N-75-B type II
519	Shure N-75-G type II
520-DE	Shure N-75-ED type II
521	Ortofon D-20 S
522	Ortofon D-20 E
523	B.S.R. ST-19; ST-22
524	Audio Sonic Coner RCS Continental Edison Europhon Lenco RCS; Pop Stereo Lesla Nordmende Saba RPC-1000 Thompson Wilson
525	Electro Voice 2647 Magnavox 560347-1
526	Excel ES-70-S Lenco M-100 blue Luxor 3831; 3833; 36200 Neat VS-80 Sanyo ST-25 D; MG-25 Telefunken TM-400
527	Excel ES-70-F (O.E.M.) Lenco M-100 Marlux
528-DE	Excel ES-70-E
529-DE	Excel ES-70-EX
530-ES	Excel ES-70-EX-4
531	Sony ND-114P; VM-10P
532	Aimor Electro Voice 2649; 5600 D Sony ND-127; VX-23 P
533	Jelco SMC-101 Mastercraft SMC-101 Neat
534	Grundig GP-500 MK II Philips GP-400 MK II; GP-500 MK II Radiola GP-500 MK II
534-DE	Philips GP-412; GP-413; GP-421 GP-401 MK II; GP-406 MK II; GP-412 MK II; GP-501 MK II Radiola GP-501 Mark II
534-ES	Philips GP-422; 422 Mark II
535	Osaka Onkyo DN23; OC-23M; SN-19 ST
536	Sanyo ST-10 D; MGT-3
537-DE	Dual DN-380 E; TKS-380 E
538	Sansui MCI-5; SN-25 Mastercraft MCI-5 Jelco MCI-5
539	Pickering V-15/D-1507 AM; V-15 P/AM
539-DE	Pickering V-15/D-1500 AME V-15 P/AME
540	V.E.B. KSS-0162
541	Kenwood N-34 Trio N-34
542	Audio Technica AT-55 Sanyo ST-25 J Toshiba N-13 C; C-27 M Yamaha N-5500
543	Philips GP-204; GP-205
544	Sharp N-03 D
545	Nivico DT-33 H
546	Pickering XV-15/350; D-350
546-DE	Pickering XV-15/400 E; D-400
547	Pickering V-15 series with brush
547-DE	Pickering V-15 E series with brush
548	Stanton 681 A; D-6807 A
548-DE	Stanton 681 E; 681 EE; D-6800 E; D-6800 EE
549	Stanton 500 A; D-5107 A; 500 AA; D-5107 AA
549-DE	Stanton 500 E; D-5100 E; 500 EE; D-5100 EE
550-ES	Expert Quadro Nagaoka Tonacord TM-1000 S Tonar JT-322

TONAR No.	May be used as replacement for:
551	A.K.G. X2R; PU-2R; X3E; PU-3E Grado F-series
552	Nivico DT-25H
553	Philips GP-212; GP-213
554	Valkona/V.E.B. KS-23
555	Expert expert; popular Nagaoka Supraphon JT-311 Tonar JT-311
555-DE	Expert Ellipse
556	B.S.R. ST-20/21 Onkyo DN-31 ST Sony ND-ST 21
557	Teppaz Jupiter
558	Pickering U-38/380-D-3807 C
559	Pickering U-38/380-D-3807 A
560	A.D.C. 220-X; R-20-X
561	Elac DM-410
562	Ronette SM-500/7
563	Cosmo G.62-30 M-23 (short tube)
564-DE	A.D.C. 220-XE; R-20-XE
565	Goldring G-820 Lenco M-150
566	Mitsubishi 3D-25
567-DE	Shure VN-15 E
568	Audio Technica AT-10 National EPS-35 STSD N.E.C. LP-7000 D Sanyo ST-36 VD Thompson AT-10 Toshiba N-53 DY
569	Elac SN-11
570	Toshiba N-300-C; C-300 F
571	Akai APN-2 Audio Technica MG-35 V Audio Technica VM-8-7 D Electro Voice 2660 Fisher ATS-10 L; ST-35 VD Magnwood N-32; N-33 Magnavox 560356 Mitsubishi 3 D-40 M National EPS-31 Nivico DT-31 Onkyo DN-27; DN-32 Sanyo MG-35 V; ST-35 VD Sharp N-20 D; STY-202 Sony ND-129-G; VM-25 G Toshiba N-14 D Trio N-32; N-33 Teleton DST-17/S-100 G; CS-400/401 Yamaha N-6500
572	Audio Technica AT-VM-35 Electro Voice 2671 D; 6012 D Magnavox 560398
573	Cybernet Jelco MC-9 Rotel 2RC-3 Sanyo ST-15; MG-15; ST-15 GD; LD Sansui SN-26 Silver System 110; 1500 Tensai Jelco 9A Pioneer PN-35 Sanyo ST-8; 42 K; MGT-2 C.E.C. MC-5 C.E.C. MC-7 N.E.C. LP-55 D Sanyo STG-1 Sharp STY-707 Toshiba N-3 C; C-03 C; C-10 C
579-DE	A.D.C.-XLM
580	A.D.C.-VLM
581	Audio Technica AT-3472 P Hitachi DS-ST 12; DS-ST-14 National EPS-91 SMAD N.E.C. AT-3472 P Sony ND-145 Sherwood ATN-3472 EP
581-DE	Mitsubishi 3D-33 M
582	Philips GP-371
583	Pickering V-15 Micro IV AC, AT, AM series
583-DE	Pickering V-15 Micro IV ACE, ATE, AME series
584-DE	Dual DN-352; V-15 III L-M Shure V-15 III L-M

TONAR No.	May be used as replacement for:
584-DE	Shure VN-35-E (V-15 type III)
585	Garrard KS-41 B Sonotone 3539
586	Garrard KS-41 C Sonotone 3559
587	Garrard GCS-38; GSS-2 Sonotone 2529
588	Pioneer PN-16; PN-330
589	Onkyo DN-24
590	Sansui SN-31; ST-3200; V-3030
591	Pioneer PN-30
592	Lesla K-3
593-DE	Goldring G-800 Super E
594-DE	Goldring G-800 E
595	Nivico DT-29
596	Hitachi DS-ST-5 Nivico DT-27
597	Pioneer PN-50
598	Micro V-2100
599	National EPS-52 National EPS-290 SD National EPS-440 QD
599-ES	National EPS-28
600	Hitachi DS-ST-40; MT-10
601	Roelofs RD-121 Silver System 90 Teac Sonovox SN-300
602	Pickering PD-07 T; V-15 P/DT
603	Pickering PDE
604-DE	N.S.M./Wurlitzer N-17 CM
605	Shure Jukebox N-17 CM National EPS-19 single tip Hitachi DS-ST-101 Piezo YM-114
606	Excel QD-700 CR Sanyo ST-27 D; MG-27 Telefunken TM-500
607	Excel QD-700 ER Excel QD-700 XR Ortofon M-20 E
608	Sony ND-132 G; VM-22 G; VM-26 G Sony ND-133 G; VL-30 G Tonar CDS-650 repl. cartr. Shure N-91 GD Dual DM 101 M-G; DN-340 Pioneer PN-20 Schneider M-74 CS; SBD-71 Shure M-81 MC Shure M-75 C jukebox National EPS-18 ST; EPS-18 STSD
609-DE	Audio Technica AT-14 S
610-ES	Nivico 4 DT-20X
611	Audio Technica AT-12 S
612	Nivico 4DT-30 X; 4DT-35 X
613	National EPS-46 STQD
614	Tenorel T-2001
615	Unitra MF-100; MF-102
616	Tenorel T-2001/ED
617	Tenorel T-2001/SD Shure N-91 ED Dual DM-103 ME; DN-345
618	A.D.C. K series
619-ES	A.D.C. Q series Fidelity
620-ES	Empire 66/X Empire 66 E/X
621-ES	National EPS-451 QD
622	National EPS-36 STSD
622-DE	National EPS-45 STQD
623-DE	A.D.C. 660
624	Acos M-6 Excel ME-35
625	Sanyo ST-30 D; MG-30
626	Acos M-6 E
627	Acos M-6 EX
628-ES	Sony ND-131 G; VM-1200 G
629	Micro V-3200
630-ES	Micro V-3200 E; V-3200 XE
631	C.E.C. MC-20
632	Jelco D; MC-14 Mission 773 MM N.E.C. LP-8300 D Tensai
633	Shure M-95 ED
633-DE	
634-ES	
635	
636	
636-DE	
637	
638-DE	



TONAR No.	May be used as replacement for:
639	Victor DT-26
640	Victor DT-33-G
641	N.E.C. LP-45 D Sharp STY-706
642	B.S.R. ST-23 sapphire
643	Electro Voice 5078 new execution; old execution: Tonar nr. 434
644	Japan Columbia DSN-14
645	Hitachi DS-ST-25
646	Mitsubishi 3D-31 M Piezo Y-670
647	Mitsubishi 3D-30 M
648	National EPS-11; EPS-11 STSD Onkyo DN-14 ST
649	Mitsubishi MD-2; 3D-37 M
649-DE	Mitsubishi MD-1
650	National EPS-46 STSD
651	Audio Sonic Blaupunkt P-60 N.E.C. LP-5100 D Onkyo DN-1005 ST Sansui SN-28 Schneider Sharp STY-104
652	Sanyo ST-36 D; MG-36
653	N.E.C. LP-35 D Sharp N-14 D; N-16 D; STY-450
654	Kenwood N-25; N-30 Trio N-25; N-30
655	Trio N-31 Kenwood N-31
656	Trio N-36 Kenwood N-36
657	Trio N-37 Kenwood N-37
658	Trio N-43 Kenwood N-43
659	Nivico DT-23
660	Aiwa M-32 Nivico DT-32 Sharp STY-701
661	Marlux NM-106 Teleton MST-5
662	Sony ND-134; VL-32 G
662-DE	Sony ND-134 G; VL-34 G
663	Sanyo ST-28 D; MG-28
664	Nagaoka JT-511 Supraphon JT-511 Tonacord TM-511
665	C.E.C. MC-11 Piezo YM-118
666	Marlux MC-500
667-DE	Empire 2000 E/III
668-DE	Empire 4000 D/III
669-DE	Stanton 681 EEE; D-6800 EEE
670	Excel QD-700 FR
671	Audio Technica AT-VM3
672	Lenco M-94
673	N.E.C. Sansui SN-80; SC-80 Silver Teleton
674	Hitachi Mitsubishi 3D-34 M
675	Pioneer PN-14
676	Audio Technica CN-933; CN-936 Garrard ATN-936 Schneider CN-933
677	Akai APN-5 Audio Technica AT-11; CN-2398 Hitachi DS-ST-26 Japan Columbia DSN-28 Luxman ATS-11 National EPS-30 STSD Thompson ATS-11 Toshiba N-52 DY Trio N-41 Kenwood N-41
678	Shure M-95 G; M-95 G-LM Dual DN-360
679	Sony ND-111 E; 112 E; VC-8 E
680	Excel ES-70 H
681	Hitachi HN-ST-7

TONAR No.	May be used as replacement for:
681	Sharp STY-717
682-DE	Goldring G-820 E
683-ES	Nagaoka JT-333
684-ES	Expert Super Nagaoka JT-555
685	Schumann/Merula STC-488
686	Trio N-35 Kenwood N-35
687	Marantz TT-520
688-ES	Kenwood N-44 Sanyo ST-45 DX Trio N-44
689	Sansui SN-27
690	Yamaha N-3500; N-4000
691	Aiwa AN-87-43 Sanyo ST-26 D; MG-26
692	Denon DSN-61 Japan Columbia (Denon) DSN-61
693	Sony ND-115 G; VM-11 G
694-ES	Sanyo ST-40 DX; MG-40 X
695	Hitachi DS-ST-55; MT-55
696	Sharp STY-705
697	Sharp STY-752
698	Onkyo DN-25 ST
699	Jelco MC-12
700	Jelco MC-15
701-ES	Jelco 4 C-1X
702	Sharp STY-102
703-ES	Nivico 4 DT-2X
704	Nagaoka NR-2
705	Japan Columbia DSN-34 Sharp STY-555
706	Mitsubishi 3D-38 M
707-ES	Shure M-24 H
708	Onkyo DN-57 ST
709-DE	Audio Technica AT-15 XE
710	Pioneer PN K-85 Sansui SN-37; SC-37 Sharp STY-114 Silver system 200; SS-250
711	Glanz MG-55 R Hitachi DS-ST-102 N.E.C. LP-50 D Sharp STY-100; STY-750
712	Sansui SN-41 Sharp STY-103 Silver System 100; 300 Teleton MST-31
713	Tensai
714	Sansui SN-42
715	Nivico DT-50
716	Pioneer PN-131
717	Yamaha N-7000
718	Nagaoka OS-100 MP
719-DE	Nivico DT-Z 1 S
720	Nagaoka OS-200 MP
721-DE	Nivico DT-34 S
722-ES	Nagaoka OS-300 MP
723-ES	Sharp STY-751
724	Hitachi F-22 EX; MT-22
725	B.S.R. Electronic Reproducers 450 M Hape MD-4 Lesa
726	Sonic S-10 C N.E.C. LP-6100 D; LP-6300
726-ES	Onkyo DN-29 ST
727	Onkyo DN-28 ST
728	Sony ND-100 G; VL-100 G Expert Disco Nagaoka JT-511 DJ
729	Audio Technica AT-7
730	Glanz MG-50 R Kenwood N-47 N.E.C. LP-65 D Sharp STY-101 Trio N-47
731	Sony ND-15 G; ND-15 GA; XL-15 A XL-15; VL-15 G
732	Dual DMS-210; DN-211 Schneider DN-211; DMS-210
733	Pioneer PN-135
734	Akai PC-100; RS-100 Audio Sonic

TONAR No.	May be used as replacement for:
734	Europhon Hitachi DS-ST-103 Magnavox 560418 Piezo YM-308
734-DE	Akai RS-120; PC-120 Eagle P-750 E
735	Micro V-3300/7
736	78 R.P.M. needle for: Nagaoka JT-511 series; JT-555 Expert Disco; Super
737	78 R.P.M. needle for: Nagaoka JT-311; JT-322 Expert Popular; Ellipse;
738	Quadro Expert Sanyo ST-20 D; MG-2; ST-27 DL; MG-27 L Tensai
739-ES	Nivico DT-Z 1
740-ES	Nivico DT-X 1 MK II
741	National EPS-31 SPSD N.E.C. LP-8000 D
741-DE	Audio Technica AT-11 E Denon DSN-54 Japan Columbia (Denon) DSN-54 Thompson ATS-11 E
742	Sony ND-50 G; VX-50 G
743	Shure M-70 B
744-DE	Shure M-70 EJ
745	Elac STS 144-17; D 144-17
746-DE	Nagaoka JT-511 BE
747	A.D.C. P-series
748	National EPS-34 STSD
748-DE	Audio Technica AT-12 E Hitachi DS-ST-104 National EPS-34 STSD; EPS-35 STED Saba AT-12 E; (PSP-244) Toshiba N-59 DY
749	National EPS-56
750	Elac STS 155-17; D 155-17 Schneider D-155-17
751	Elac STS 255-17; D 255-17
752	Elac STS 355-17; D 355-17
753	Aiwa AN-87-45 Akai RS-38 Barco C.E.C. MC-16 Piezo YM-121 Silver SL-5050
754-ES	Sony ND-45 X; XL-45
755	Kenwood N-46 Trio N-46
756	Acos M-7 Eurofunk EF-85; EF-404
756-DE	Acos M-7 E
757	Aiwa AN-6 National EPS-270 SD Blaupunkt EM-240
757-DE	National EPS-270 ED
758	Audio Technica ATN-71 Brandt Continental Edison Grundig I.T.T. AT-71 Japan Columbia (Denon) DSN-39 Kenwood N-11; N-48 Luxor Marantz 500 National EPS-74 STSD N.E.C. LP-735 D Onkyo DN-35 ST Rotel 2RC-5 Scott Sharp STY-115 Siemens Teac Teleton ATN-71 Trio N-11; N-48
759-DE	National EPS-50; 51; 54; 205 ED
759-ES	National EPS-405 QD
760	Fisher MG-63; ST-63 D N.E.C. LP-6000 D Sharp STY-105
760-DE	Siemens Audio Technica ATN-72 E



TONAR No.	May be used as replacement for:
760-DE	National EPS-74 STED Sanyo ST-63 D
761	Supraphon JT-411
762-DE	Dual D-105 ED; DN-362
763	Hitachi DS-ST-24; MT-24
764	Audio Technica ATN-952 Kenwood N-49 Trio N-49
765-DE	Sony ND-45 E; XL-45 E
766-DE	National EPS-205 EX; National EPS-205 ED III
767	Hitachi SJN-18 Japan Columbia (Denon) DSN-38 Mitsubishi SJN-18 Sanyo ST-17 D; MGT-17
768	Toshiba N-55 DY
768-DE	Audio Technica ATN-71 E Grundig Luxman ATN-71 E Radio Shack ATN-71 E Toshiba N-57 DY
769	Handic V-307 Micro V-307; V-7000
770	Denon DSN-34 Glanz MG-70 R Hitachi DS-ST-23
771	Audio Technica ATN-952 Kenwood N-26 Mitsubishi 3D-44 M Nordmende ST-10 J Onkyo DN-40 ST Pathé Marconi ST-10 J Sanyo ST-10 J; MG-10; MG-10 J; ST-11 D; ST-43; ST-43 D Trio N-26
772	Japan Columbia DSN-41
773	Sony ND-14 G; VL-14 GS
774	Pioneer PN-330 MK II
775	Micro VP-1; V-8; V-10; V-70
776	Micro V-5
776-DE	Braun MAG 1 E
777	Micro V-20
778	Audio Technica ATN-936 Onkyo DN-33 ST Sony ND-135 G; VM-27 G
779	Rigonda 123 Schneider KS-231 Valkona CN-24; KS-231 V.E.B. CN-24; KS-231
780	Audio Technica AT-3 Kenwood N-20 Trio N-20
781-DE	Audio Technica AT-12 XE Continental Edison I.T.T. AT-12 XE Sanyo STA-3 D Telefunken TM-600 Thompson ATN-12 XE
782-ES	Audio Technica AT-12 Sa
783-DE	Audio Technica AT-13 E
784	Hitachi DS-ST-20
785	Audio Technica ATN-936 Yamaha N-4500; N-4500 MK II
786	Japan Columbia DSN-22 N.E.C. LP-30 D
787	Sanyo ST-4 D
788	Sanyo ST-50 D; MG-50
789	A+R/Cambridge P-77 Marlux
789-ES	A+R/Cambridge P-78
790	Sonovox 50 S
791	Sonovox N-11 S
792	Eurofunk EF-505 Marlux SX-50 S Sonica SK-58 C Sonovox S-101 C
792-DE	Eurofunk EF-606 Sonovox S-101 E
792-ES	Eurofunk EF-707 Sonovox S-101 SH
793-DE	Empire 2000 Z
794-DE	Audio Technica AT-13 Ea I.T.T. AT-13 E Saba AT-13 EaV; (PSP-248) Siemens 555

TONAR No.	May be used as replacement for:
794-DE	Thompson ATN-13 Ea
795	I.T.T. AT-70; ATN-70 Magnavox 560369 Saba AT-71 (CSP-300) Schneider ATN-70 Sharp CN-2423 Sony ND-136 G; VL-33 G Wega ATN-70
796-ES	Audio Technica AT-14 Sa
797	Pioneer PN-110 MK II
798-DE	Shure VN-45 HE; V-15 type IV
799	Pioneer PN-400
800	Pioneer PN-600
801	Crown Fidelity Hitachi SJN-45 Japan Columbia DSN-45 Magnavox 560 4370033 Nikko Nivico DT-51 Sanyo STG-5; STG-6; MGT-45; ST-170; GXT-170 Schneider SP-60 N; SP-61 M Silver SS-3850 Teleton Tensai
802	Brandt FF-15 O MK II Kenwood NF-15 O MK II Luxor 8000 Ortofon FF-15 MK II Trio NF-15 O MK II
802-DE	Onkyo DN-60 STE
803	Kenwood N-15 O MK II Ortofon F-15 MK II Trio N-15 O MK II Toshiba N-58-C; C-58 M
804	Stanton 881 S; D-81
805-DE	Audio Technica AT-13 Ea/X
806-DE	Sony ND-60 G; VX-60 G
807	Nagaoka C-711-01; C-711
808	Philips GP-397 MK III
809	Excel ME-45 I.T.T. ME-45-77
810	Onkyo DN-16 ST
811	N/A
812	N/A
813	Aiwa AN-35 Crown Fisher ST-34 D N.E.C. LP-75 D Nivico DT-36 Rotel System 400 Samsung 4237 Sanyo STG-8 Schneider SP-62 M Siemens Silver System 70; System 75 Silver SS-85; SS-170; SS-270 Tensai
814	Ortofon FF-15 X MK II
814-DE	Ortofon FF-15 XE MK II
815	Tonacord TM-1000
816	Sony ND-108; VM-108 GS Toshiba N-260 C; C-260 M Onkyo DN-39 ST
817	C.E.C. MC-10
818	Sony ND-137 G; VL-37 G
819	Dual DMS-220; DN-221
820	Schneider DN-221; DMS-220 Dual DMS-240 E; DN-241 Dual DMS-242 E; DN-242 Schneider DN-242; DMS-242 E
821-DE	Aiwa AN-36
822	Cybernet Mitsubishi 3D-48 M N.E.C. LP-60 D Samsung 150; 350 Sanyo ST-107; STG-2D; ST-48 D Sharp STY-117 Teleton MPC-7; MST-6
823	Japan Columbia (Denon) DSN-44 Sansui SN-44 Sansui SN-45
824	Sansui SN-45
825	Sansui SN-50
826	Sanyo STG-7

TONAR No.	May be used as replacement for:
826	Toshiba N-210; C-210 M; N-230 C; C-230 M
827	Bellex BX-50
827-DE	Bellex BX-50 E
828	Audio Technica ATN-771 Hitachi DS-ST-30 Japan Columbia (Denon) ATN-771 Rex (Zanussi) Sansui SN-101; SV-101
829	Kenwood N-39 MK III Trio N-39 MK III
830	Garrard GMC-50 C
831	Aiwa AN-7 Akai PC-90; RS-90 Audio Technica ATN-3711; ATN-3721 CN-2701; Garrard GA-150 National EPS-76 STSD Tensai Thompson ATN-3721
832	Aiwa AN-5; RN-5 Audio Technica ATN-3400; ATN-3450 Blaupunkt CN-5431 Continental Edison Cybernet Grundig Hitachi DS-ST-35; DS-ST-36 Inkel PD-40 I.T.T. Japan Columbia ATN-3400 K.L.H. Marantz ATN-3400; CT-5 S National EPS-75 STSD; EPS-77 ST N.E.C. LP-355 D Onkyo DN-52 ST Saba CN-5431 (C-3000); AT-3400 (PSP-240); AT-3400 (PSP-100) Sanyo ST-55 D Schneider Sony ND-138 G; VL-38 GS Toshiba N-71 C; C-71 M Uher Wega
833	Sanyo ST-31 J
834	Japan Columbia DSN-50 N.E.C. LP-70 D Crown Piezo YM-123 Piezo YM-310
835	N/A
836	Excel ME-55
837	Pioneer PN-150
838	Fisher ST-44 D
839	Sanyo ST-44 D Silver system 70 Fisher MC-100 S Sanyo ST-100 SD
841	National EPS-207 C
841-DE	National EPS-207 ED
842	National EPS-27; EPS-275;
843	Bang & Olufsen SP-10
844-DE	Bang & Olufsen SP-12
845	Bang & Olufsen SP-14
846	Yamaha N-6600
847	Audio Technica ATX-11
847-DE	Saba ATX-11 E
848	Onkyo DN-201 ST Sony ND-5 G; VL-5
848-DE	Audio Technica ATN-3712 E Onkyo DN-202 STE Sony ND-7 E
849	Audio Technica ATN-3712 Fisher MG-53; ST-53 D Sanyo ST-53 D; ST-53 ZD; MG-53 Z
850	Audio Technica ATN-770 L National EPS-39 STSD Rotel 2RN-5 Yamaha N-6600 S
851	Audio Technica ATN-3401; ATN-3450 L Magnavox 560429 National EPS-75 STC/SD; EPS-76 STED; EPS-77 ST Nikko Pioneer PN-220



TONAR No.	May be used as replacement for:
851	Sanyo ST-35 D; ST-41 J Sharp STY-118 Toshiba N-293 DY Visonik Yamaha N-6700
852	Micro V-40
853	Nivico DT-30 S
854-DE	Sony ND-25 E; XL-25; XL-25 A
855	Sony ND-35 E; XL-35
856	Empire Scientific 2000
857-DE	Empire Scientific 2000 E Schneider SPP-30
858-DE	Empire Scientific 4000 D/II
859-DE	Empire Scientific 2000 E/II
860-DE	Empire Scientific 2000 E/II
861-DE	Empire Scientific 4000 D/II
862	Glanz MG-20 R Onkyo DN-51 ST Rotel 2RC-1 Sharp STY-116 Toshiba N-160 C; C-160 M Sony ND-220 G; VL-20
863	Audio Technica ATN-750
864	Yamaha N-6800
865	Audio Technica ATN-750 Fisher ST-41 D Inkel JB-2000 Sanyo ST-41 D; ATN-750
866	Audio Technica ATN-750 C.E.C. ATN-750 Teac
867	Audio Technica ATN-105
868-DE	Audio Technica ATN-110 E Rotel ATN-110 E
869-DE	Audio Technica ATN-120 E
870-ES	Audio Technica ATN-125 LC
871	Audio Technica AT-103 Sound Burger Hitachi DS-ST-17
871-DE	Audio Technica ATN-130 E
872-ES	Audio Technica ATN-140 LC
873-ES	Audio Technica ATN-155 LC
874	Tetrad T-5 H
875	Tetrad T-2 MS; T-2 MD
876	Kenwood N-53/V-53 Toshiba N-33 C; C-911 Trio N-53/V-53
877	Sansui SN-60; SC-60 Teac PC-313 Tensai
878	A.D.C. QLM-series Brandt QLM-30 MK III Radio Shack QLM-30 MK III Schneider QLM-30 MK III Siemens QLM-30 MK III
879	Audio Technica ATN-3710 Inkel Luxman ATN-3710 Scott 21 SC Sony ND-250 G; XL-250 G
880	Sony XL-20; ND-200 E
880-DE	Sony XL-30; ND-30 E
881-DE	Piezo YM-122
882	Silver SL-5030 Piezo YM-124
883	Nivico DT-Z-4 S
884	Nivico DT-Z-3 ED
884-DE	Continental Edison Pathé Marconi National EPS-202 C; 202 ED EPC-202 CK; P-23; EPS-23 CS; EPS-23 ES; H-23; P-22
885-DE	National EPS-22 ES; EPS-23 ES; EPS-202 ED
886	National EPS-206 C
886-DE	National EPS-206 ED
887	Toshiba N-34 C; N-35 D; C-34 M; C-35 M; N-68
888	Glanz MG-30R Rotel 2RC-4
889	Akai RS-3 J
890	Piezo YM-125
891	Electronic Reproducers ER-312 X Piezo YM-320
892	Denon DL-8 A; DSN-42 Japan Columbia DSN-42

TONAR No.	May be used as replacement for:
893-DE	Saba ATN-12 ES (PSP-250)
894	Audio Technica ATN-11 S Onkyo DN-37 ST
894-DE	Hitachi DS-ST-26 E
895	Audio Technica ATN-72 Inkel Telefunken ATN-72
896-DE	Akai RS-95; PC-95 Audio Technica ATN-3721
897	Akai RS-83 Audio Technica ATN-3412 Mitsubishi 3D-47 M
898	Audio Technica ATN-93; ATN-3410 ATN-3451 Marantz ATN-3400 National EPS-75 TFSD Nivico DT-38 Sansui SN-202 Sanyo ST-42 D Sherwood Siemens RW-150 Teac Telefunken ATN-3410 Tensai
899-DE	Akai PC-150; RS-150
900	Audio Technica ATN-3721
901	Shure N-97 B
901-DE	Radio Shack RXT-4 Rotel RXT-4 Shure N-97 ED Shure N-97 HE
901-ES	Sony ND-150 (not ND-150 G)
902	Audio Technica ATN-750
903	Sanyo ST-41 ZD
904	Audio Technica ATN-51; 52; 53 Garrard GS-22 Inkel PD-607 I.T.T. ATN-50 Nordmende Saba Sanyo ST-51 D Sherwood Sony ND-139 G Telefunken Thompson T-H 5 S Wega ND-139 G
904-DE	Audio Technica AT-51 E; AT-52 E; AT-53 E; AT-55XE; AT-57 XE; 59 XE Brandt Garrard GS-22 E Rotel AT-51 E; ST-51 D Saba Thompson T-H 5E Sharp STY-121
905	Nivico DT-37; MD-1034
906	Sony ND-150 G; XL-150
907	Jelco D
908	Kenwood N-50 Trio N-50;
908-DE	Kenwood N-51 E Trio N-51 E
909	C.E.C. MC-17 Teac
910	Grundig Magnavox 560434 Schneider Sears Sharp Siemens RS-226. Tensai Toshiba N-21 D
911	Dual DN-140 S; ULM-40 S
912	Pioneer PN-230
913	Mitsubishi 3D-50M Sharp STY-128
914	Nagaoka C-320 M Toshiba N-320; C-320 M; N-330 D; C-330 M
915	Audio Technica ATN-70 L Sanyo ST-26 J Toshiba N-56 DY
916	Audio Technica ATN-3601 Magnavox 25130071 Philips Sharp STY-123

TONAR No.	May be used as replacement for:
916-DE	Onkyo DN-63 STE
917	Audio Technica ATN-3600; ATN-3650 Brandt National ATN-3600 Nordmende Pathé Marconi Saba Sherwood Telefunken Tensai Thompson
918-DE	Micro LF-7
919	Sony XL-20 G/ ND-200 G
920	C.E.C. MC-6 S Cobra 250; 520 Schneider Toshiba N-20 C
921	Excel ME-65
922-DE	Audio Technica ATN-3711 E Marantz ATN-3711 E; CT-6 S
923-DE	Nivico DT-39; LF-71 Onkyo DN-55 ST; DN-59 ST
924-DE	Empire 2000 X
925	Audio Technica Toshiba N-60 DY; N-70 C
926	Akai RS-84
927	Audio Technica AT-102 P Grundig ATN-102 Inkel ATN-102 P National EPS-90 SMBD; 90 STGD N.E.C
928	Audio Technica AT-892 Sanyo ST-38 D; ATN-892
929	Yamaha N-8000
930	Nivico DT-41; LE-500; LE-600
931-DE	Denon DL-60 Japan Columbia DSN-60
932-DE	Nivico DT-Z 1 EB
933	Akai RS-85; PC-85 Audio Technica ATN-3401 Philips 499 Sharp STY-130 CX-680 6C (801 DS plastic cant.) Rex (Zanussi) Sharp STY-132 Silver S-8300 Tensai Toshiba N-40 C
934	Aiwa AN-70 Akai RS-77 Audio Technica ATN-3851 Brandt Continental Edison Kenwood N-56; N-56 B Marantz TT-333; TT-433; TT-443; TT-553 Mitsubishi 3D-54 M Sansui SN-303 Thompson Toshiba N-72 D; C-72 M Trio N-56; N-56 B
935	Audio Technica ATN-70 Mitsubishi 3D-42 M; 3D-45 M Denon DSN-47 N.E.C. LP-310 D Japan Columbia DSN-47 Denon DSN-48 Japan Columbia DSN-48
936	Hitachi DS-ST-15 Grundig P-24 National EPS-24 CS Schneider P-24
937	National EPS-24 ES Sharp STY-120
938	Audio Technica ATN-3710 L Nagaoka C-721 Nagaoka MP-05 Toshiba N-310 C; C-310 M
939	Nagaoka MM-321 B Teleton MM-321B
940	Philips GP-400 MK III Philips GP-401 MK III Empire 2000 T Amstrad T-30 MS; T-30 MD Schneider T-30 MS
940-DE	
941	
942	
943	
944	
945	
946	
946-DE	
947-DE	
948	



TONAR No.	May be used as replacement for:
948	Tetrad T-30 MS; T-30 MD Waltham T-30 MS
949	Japan Columbia DSN-51 Onkyo DN-54 ST Piezo YM-127
950	Toshiba N-62 C; C-62 M; N-66 C; C-66 M; N-67 C; N-67 M
951	National EPS-41 STSD; EPS-41 ST Sanyo ST-03; ST-50 D
952	C.E.C. MC-45 Jelco MC-45 D
953	Aiwa AN-60 Osawa OS-1001 Pioneer PN-K-65
953-DE	Osawa OS-2001 Osawa OS-3001
954	Sanyo ST-20 J
955	Onkyo DN-56 ST
956	Inkel JB-4000; JB-5000 Marantz N.E.C. Nikko Rotel Samsung LP-4 Scott 20 SC Sharp SG-20 music centre; STY-127 Silver SLU-30 Uher
957	Aiwa AN-50 Audio Technica ATN-3830; ATN-3831 Denon DSN-63 Hitachi DS-ST-16 Japan Columbia (Denon) DSN-63 Mitsubishi 3D-51 M Nivico DT-56 Sharp STY-124
958	Kenwood N-39 MK II Trio N-39 MK II
959	National EPS-27 CS; EPS-28 CS
960	Tonar 511
960-DE	Tonar 511 BE
960-ES	Tonar 555
961	Nordmende Sansui SN-505
962	Toshiba N-45 C; C-45 M
963	Hitachi DS-ST-32 Toshiba N-64 C; C-64 M (IM)
964	Stanton 600 A; D-6071 A
964-DE	Stanton 600 E; D-6004 E; 600 EE; D-6003 EE
965	C.E.C. RS-3 Marantz Scott 21 A SC
966	Shure SC-35 C; SS-35 C
968	Empire Scientific 100 S
968-DE	Empire Scientific 200 E
969	Dual DN-237; TKS-237
970	Dual DN-145 S; ULM-45 S
970-DE	Dual DN-145 E; ULM/TKS-45 E Schneider DN-145 E
971	Sanyo ST-15 J
972	Sanyo ST-29 D; ST-55 D Toshiba N-50 C; N-51 C
973	Marantz CS-500 Nikko Sanyo STG-11 Schneider SFP-26 Toshiba N-292 Uher
974	Audio Technica AT-91; ATN-91; ATN-3601; ATN-3651 Blaupunkt Europhon Luxman Nivico DT-55 Pioneer PN-320 Saba Sanyo Sony ND-142 G; VL-42 G Teleton Tensai
975	Sanyo ST-101 SD
976	Audio Technica ATN-3230 Yamaha N-8010; MC-801
977	Sony ND-143 G; VL-43 G

TONAR No.	May be used as replacement for:
978	Hitachi HT-20 S
979	Hitachi DS-ST-33
979-DE	Audio Technica ATN-112 EP Sherwood AT-112 EP
980	Amstrad Denon DSN-57 Japan Columbia (Denon) DSN-57 Sanyo STG-9; MG-17-10 Sherwood MC-1710
981	Audio Technica ATN-2005; ATN-3600 L; ATN-3650 L Dual DN-235; DMS-235; DN-239; DMS-239 Grundig DN-235; DN-239 Rotel Schneider DN-239 Siemens DN-239
982	Akai RS-7; PC-7
982-DE	Hitachi DS-ST-33 E
983	Japan Columbia (Denon) DSN-62 Denon DSN-62 Supex SM-38
984	Supex SM-38 E
984-DE	Supex SM-38 E
985	Mitsubishi 3D-52 M Sansui SN-707
986-DE	Audio Technica AT-102 EP Grundig ATN-102 EP Hitachi DS-ST-13; MT-13 National EPS-90 SMAD; 90 STGED
987	Nivico DT-55 MK II Sharp RP-23; RP-35; STY-140
988	Nivico DT-201
989	Sanyo STM-11; MG-M 11 Sharp STY-131
990	Akai RS-82 Audio Technica ATN-2004
991	Audio Technica ATN-3600 C; ATN-3650 C National EPS-43 STSD; 75 STHSD Sharp STY-141; STY-142 Teac PC-707; N-707 Yamaha CG-7700; N-7800
992	Sharp STY-122
993	Marantz CT-100
994	Magnavox 25130079 Philips GP-330 Radiola GP-330
994-DE	Magnavox 25130081 Philips GP-331 Radiola GP-331
999	Steel needles in box of 200 pcs
6001	Hitachi HN-ST-6 Tetrad T-20 MS; T-20 MD
6002	Tetrad T-3 MS; T-3 MD
6003-ES	Nagaoka JN-110
6004	Garrard GC-11
6005-DE	Coral 666 EX
6006	Decca Deram
6007	Tetrad T-12 MD; T-12 MS
6008	Kenwood N-52 Trio N-52
6008-DE	Audio Technica ATN-3452 E
6009	Mitsubishi 3D-46 M
6010	Sansui SN-70; SC-37 A
6011	Audio Technica ATN-3472 P Sanyo ST-26 DL
6011-DE	Audio Technica ATN-3472 EP
6012	Sanyo ST-34 D
6013	Micro 307 IM
6014	Aiwa AN-30 Sharp STY-137; RP-255 Teleton N-1520
6015	Sharp STY-136; RP-155 Tensai
6016	Denon DSN-66 Japan Columbia DSN-66 Sanyo STG-10; GXT-210; GXT-410 Sherwood
6017	Sanyo ST-37 LD
6018	Shure M-97 LT
6019	Shure SDS-1
6020	Shure M-44 C with guard
6021	Kenwood N-54 Trio N-54

TONAR No.	May be used as replacement for:
6022	Sony ND-MM 1 G; XL-MM 1
6022-DE	Sony ND-MM 2 E; XL-MM 2
6022-ES	Sony ND-MM 3 X; XL-MM 3
6023	National EPS-25 CS
6024	National EPS-23 CS
6025	C.E.C. ST-630
6025-DE	Excel ESP-300 E
6025-ES	Excel ESP-300 X
6026	Excel ESP-300 C Marantz TT-530 Denon DSN-65 Japan Columbia (Denon) DSN-65 Jelco MC-12
6028	Ortofon VMS-20 E
6029	Dual DN-149 S; TKS-49 S
6030	Dual DN-152 E; TKS-52 E
6030-DE	National EPS-30 CS
6031	National EPS-33 ES
6032	Dual DN-155 E; ULM/TKS 55E
6033-DE	Dual DN-160 E; ULM/TKS-60E
6034-DE	General Electric VR-II/G-16 only
6035	Onkyo DN-62 ST
6036	Sanyo ST-102 S; ST-102 SD Sharp STY-138
6037	Fidelity T-50 HS
6038	Schneider T-50 HS Tetrad T-50 HS A.D.C. L-3 A.D.C. Q-3
6039	Elac ESG-792 E; DN-792 E
6040	A.D.C. L-4
6041-DE	Mitsubishi L-4
6042	Tensai A.D.C. Q-4
6043	Dual DN-236
6044	Dual DN-390
6045	Sharp STY-107
6046	Toshiba N-250 C; C-250 M
6047	Audio Technica ATN-2001 Onkyo DN-61 ST
6048	Onkyo DN-61 STE Akai RS-33; PC-33; RS-35; PC-35 C.E.C. N-103 Dual DN-450; MMP-450 Grundig Pioneer PN-250 T; PN-305 T Sansui SN-P 313; SN-P 515 Teac PCS-708; PC-708 DS-ST 18 R
6048-DE	Hitachi DS-ST 18
6049	Sanyo ST-L 5 D C.E.C. U.P.O.'s white
6049-DE	Toshiba N-290 D
6050	Ortofon M-20 E Super
6051	Ortofon Stylus STD
6052	Ortofon LM-10
6053	E.E.I. 300H
6054	E.E.I. 400
6055	E.E.I. 500
6056	E.E.I. 700
6056-DE	Shure V-15 type 5
6057-ES	Sharp STY-135; RP-P8
6058	Sansui SN-909
6059	Sansui SN-29
6060	Radio Shack RT-1500
6061	Realistic RT-1500
6062	Marantz TT-140; TT-240; TT-340; TT-440
6063	Sanyo ST-44 J National EPS-75 SMLD Sanyo Sharp Sony ND-147
6064	Sansui ST-2 D Sharp N-15 D Sansui ST-9 D; SN-24
6065	Sanyo all plastic
6066	Coner Testina RC-1
6067	Onkyo DN-38 ST
6068	Empire Scientific 150 C
6069	Empire Scientific 250 E
6070	Japan Columbia (Denon) DSN-3
6071	
6072	
6072-DE	
6073	



TONAR No.	May be used as replacement for:
6074	Japan Columbia (Denon) DTS-4
6075	Japan Columbia (Denon) DSN-4
6076	Japan Columbia (Denon) DSN-5
6077	Japan Columbia (Denon) DSN-6
6078	Japan Columbia (Denon) DSN-7/DSN-8
6079	Japan Columbia (Denon) DSN-32
6080	Japan Columbia (Denon) DSN-40
6081	Onkyo DN-34 ST
6082	Onkyo DN-36 ST
6083	Sharp STY-550
6084	
6085	B.S.R. S-1; SN-1 Sharp RP-50
6086	Nuway NS-88
6087	Japan Columbia (Denon) DSN-11
6088	Mitsubishi 3D-29 M
6089	Nivico DT-12
6090	Nivico DT-13
6091	Nivico ST-19
6092	Nivico DT-22
6093	Nivico DT-15
6094	Nivico DT-18
6095-DE	Sony ND-50X; XL-50
6096-DE	Sony STA-1D
6097-DE	Shure M-92 E (new)
6098-DE	Shure M-99 E
6099-DE	Shure M-104 E
6100-ES	Shure M-110 HE
6101	Toshiba N-280 C; C-280 M
6102	Pioneer PN-200
6103	Pioneer PN-800
6104-ES	Pioneer PN-21
6105-DE	Pioneer PN-330 E
6106-DE	Pioneer PN-550 E
6107-ES	Pioneer PN-770 EX; PN-1000C
6108-DE	Nivico DT-21
6109-DE	Audio Technica AT-122 EP Inkel ATN-122 P
6110-ES	Audio Technica AT-122 LP
6111	Nivico DT-57
6111-DE	Audio Technica AT-3472 EP
6112	Sansui SN-43
6113	Yamaha N-6900
6114-DE	Yamaha N-7900
6115	Toshiba N-44
6116-ES	Toshiba N-220 ME/X; C-220 M
6117	National EPS-51 CS
6118	National EPS-P 53 CS
6119-DE	National EPS-53
6120-DE	Audio Technica AT-115 E
6121	Mitsubishi 3D-MM 1
6122	Nivico DT-55 W
6123	National EPS-02
6124-DE	Pioneer PN-550 E MK II
6125	Pioneer PN-1000 MK II
6126	Audio Technica ATN-101 P N.E.C. Scott ATN-3482 P
6127-DE	Audio Technica ATN-95 E; ATN-3451 E Sherwood
6128	Tetrad TZ-1 S; TZ-1 D Zenith 142-185
6129	Toshiba N-500 C; C-500
6130	Piezo YM-818 Visonik YM-818
6131	Toshiba N-69 D; C-69 M
6132	
6133	U.P.O.'s KP-20
6134	A.D.C. PSX-10
6135	A.D.C. PSX-20
6136	A.D.C. PSX-30
6137	A.D.C. PSX-40
6138	Kenwood N-59 Toshiba N-75 C; C-75 M; N-76 DY Trio N-59
6139	Toshiba N-74 C; C-74 M; N-74 DY
6140-DE	Pickering DTL-1; TL-1
6141	
6142-DE	Akai RS-180; PC-180
6143	Sony ND-300 G; XL-300
6144	Dual DN-450
6145	Sony ND-10 G; XL-10
6146-DE	C.E.C. MC-20 ES
6147	Sony ND-250 E; XL-250 E

TONAR No.	May be used as replacement for:
6148	Sharp STY-143
6149	Sanyo ST-40 D
6150	A.D.C. PSX-5; PSX-5 E
6151	Nagaoka JN-120
6152	Akai RS-50
	Mitsubishi RS-50
6152-DE	Akai RS-50 E
6153-DE	Yamaha N-8100
6154	Toshiba C-32 M
6155	Sony ND-142 GP
6155-DE	Sony ND-142 EP
6156	Aiwa AN-2
6157	
6158	Kenwood N-63 Trio N-63
6159	Marantz TT-430
6160	Pioneer PN-290 T
6160-DE	Pioneer PN-300 T
6161	Akai RS-10; PC-10
6162-ES	E.E.I. 800
6163	Marantz TT-551
6164	Sanyo ST-66 D
6165	Sony ND-144 G
6166	Nivico DT-55 B
6167	Pioneer PN-295 T
6168	Nivico DT-Z 5 P; Z-5 P
6169	Nivico DT-35
6170	Sony ND-301 P
6171	U.P.O.'s blue
6172	U.P.O.'s red
6173	U.P.O.'s yellow
6174	U.P.O.'s red
6175	Tensai MC-3750 U.P.O.'s red
6176	Tonar 611
6177-DE	Tonar 611 BE
6178	Audio Technica ATN-2002
6178-DE	Audio Technica ATN-3652 E
6179-DE	Audio Technica ATN-3651 E
6180	Audio Technica ATN-3492 P
6180-DE	Audio Technica ATN-3492 EP
6181	Audio Technica ATN-770
6182	Audio Technica ATN-90
6183	Kenwood N-62; V-62 Trio N-62; V-62
6184	Excel S-75 ER; ME-75
6185	Excel S-700 DR; ES-700 D
6186	Audio Technica ATN-3400 C; ATN-3450 C
6187	Audio Technica ATN-3652
6188	Audio Technica ATN-2003
6189-DE	Audio Technica ATN-101 EP
6190	Toshiba TP-116 SD
6191	Coner R-608 RCS
6192	Japan Columbia DSN-9
6193	Onkyo DN-65 ST
6194	Ronette 107 double
6195	Sanyo ST-55 D
6196	Sharp STY-144
6197	Pioneer PN-291
6198	Sanyo ST-67 D
6199	Sanyo ST-47 D
6200	Sanyo ST-57 D
6201	Acutex M-106
6202-DE	Acutex M-110 E
6203	Audio Technica ATN-3660 YL
6204	Trio N-61 Kenwood N-61
6205	Electronic Reprod. ERC-900
6206	Marantz TT-153
6207	Toshiba N-77 C
6208	Sanyo STG-12
6209-DE	Sonus Clear E
6210-DE	Sonus Black E
6211-DE	Sonus Smoke E
6212-ES	Sonus Black Bonded LC
6213-ES	Sonus Black Naked LC
6214	Supex SMM-5
6221	Empire S-111
6222	Empire S-333
6223	N.S.M. (ORTOFON)
6224	Pioneer PN-250 T
6225	Toshiba N-37 C
6226	Sansui SN-757
6227	Sharp STY-146

TONAR No.	May be used as replacement for:
6228	Sanyo ST-07 D
6229	Sanyo ST-08 D
6230	Nivico DT-59
6231-ES	Excel ME-65 X
6232-ES	Excel S-75 QL
6233	Japan Columbia DSN-67
6234	Sansui SNP-212
6235-DE	Dual DN-150 E
6236	Audio Technica AT-4-7 D black
6237	Onkyo DN-68 ST Sharp STY-155 Sony ND-155 G
6238	
6239	U.P.O.'s
6240	U.P.O.'s
6241	U.P.O.'s
6242	U.P.O.'s
6243	U.P.O.'s
6244	Onkyo DN-106 ST
6245	U.P.O.'s
6246	Nivico DT-55 MK 2
6247	Sansui SV-111
6248	Onkyo DN-107 ST
6249	Trio N-65 Kenwood N-65 Nivico DT-Z 1 E
6250-DE	Pioneer PNK-75
6251	Sharp STY-145
6252	
6254	
6255	Jelco MC-29
6256	Amstrad 900 D
6257	Trio N-66 Kenwood N-66
6258	Trio N-67 Kenwood N-67
6259	Sanyo ST-09 D Trio N-69 Kenwood N-69 Marantz CT-551
6260	Sanyo
6261	Fonica UF-70
6262	Aiwa AN-11
6263	Nivico DT-58 B
6264	Nivico DT-60
6265	Yamaha N-8300
6266	Nivico ATN-1059
6267	Mission Solitaire
6268	Japan Columbia DSN-25
6269	Andante P-38
6270	Audio Technica AT-3-5 D
6271	Andante P-76
6272-DE	Sanyo blue
6273	Jelco MC-50 D
6274	Excel ES-750 L
6275	Pioneer PN-350
6276	Fisher Price power point
6277	Tetrad T-1 LD
6278	Sansui SN-1112
6279	Audio Technica AT-4-7 D orange
6280	Sansui SN-36 orange
6281	Sanyo STG-10 (tracks 3.5-6 gr)
6282	Trio N-68 Kenwood N-68
6283	National EPS-55 CS
6284	Shure Ne-97 HE (Encore)
6285-ES	Onkyo DN-70 ST
6286	Pioneer PN-240
6287	Sharp STY-112
6288	Nivico DT-62
6289	Pioneer PN-19
6290	Kenwood N-71
6291	Trio N-71
6292	Azden YM-10 C
6293	Azden YM-10 E
6294-DE	Azden YM-10 VE
6295	Azden YM-P 50 C
6296	Toshiba N-73 CY
6297	Empire S-3 D
6298	Empire S-40
6299-DE	Empire S-45 E
6300-DE	Empire S-105
6301	Empire S-205
6302	Empire 140 C
6303-DE	Empire 245 E
6304	Empire 195 LT
6305	Empire 295 LT



TONAR No.	May be used as replacement for:
6306	EMPIRE S-395 LT
6307	EMPIRE S-485 LT
6308	EMPIRE S-1085 LT
6309	EMPIRE 300 ELT
6310	EMPIRE 500 PEX
6311	EMPIRE 15 C
6312	EMPIRE 25 E
6313	EMPIRE 150 KC
6314	EMPIRE 250 KE
6315	AUDIO TECHNICA ATN-3663
6316	AUDIO TECHNICA ATN-771 E
6317	EDISON T FOR AMBEROLA CILINDER
6318	AZDEN YMP-50 E
6319	AZDEN YMP-50 VL
6320	SHURE NV-30 HE
6321	SHURE N-11 (SPS-series)
6322	SHURE N-12 (SPS-series)
6323	SHURE N-13 (SPS-series)
6324	SHURE N-14 (SPS-series)
6325	SHURE N-15 (SPS-series)
6326	SHURE N-75 HE
6326	SHURE N-75 HE TYPE II
6327	SHURE NDC-HE (SDS-3)
6328	PIEZO YM-130 BLOCK-ELLIPTICAL
6329	A.E.U. CERAMIC RED ALL PLASTIC
6329	AEU CERAMIC RED ALL PLAST DIA
6330	A.E.U. CERAMIC ALLU CANT.
6331	SHARP STY-152
6332	SHARP STY-154 BROWN
6333	DUAL DN-150 E
6334	TRIO/KENW. N-74; N-75
6335	TRIO N-72
6336	PIONEER PN-260
6337	EPS-510 NML VVD: 6031 DS
6338	EPS-520 ES NML, VVD: 6031 DE
6339	SHURE N-75-3 NML, VVD: 386 DN
6340	NATIONAL EPS-530 ES
6341	NATIONAL EPS-540 ES
6342	NATIONAL EPS-550 ES
6343	PIEZO YM-305
6344	AIWA AN-5080
6345	AUDIO TECHNICA ATN-3609 YL
6346	PHILIPS MG-2510; SANYO ST-59 U
6347	SHARP STY-146 RED PLASTIC DIAM
6348	HITACHI DS-ST-8; HT-300
6348	HITACHI DS-ST-8 (HT-300)
6349	JAPAN COLUMBIA DSN-36
6350	PHILIPS GP-406 MK III
6351	JAPAN COLUMBIA DSN-46
6352	TRIO/KENWOOD N-77
6353	AKAI APM-70 GREY (5110.6)
6354	PHILIPS NLD 4822 251 30112
6355	ORTOFON STYLUS PRO -COPY-
6356	ORTOFON STYLUS 10 NEW
6357	ORTOFON STYLUS 5 NEW
6358	ORTOFON STYLUS 5-E NEW
6359	PICKERING DLC
6360	AKAI PL-305
6361	SHURE N-44 G DARK GREY
6362	ORTOFON STYLUS 30 COPY
6363	PHILIPS 4822 251 40143
6364	STANTON D-5100 AL - DJ STYLUS

TONAR No.	May be used as replacement for:
6365	U.P.O.S. CN-251 (CART MG-2831)
6366	AKAI CN-254 BLACK
6367	A.K.G. X 8 E
6368	ORTOFON STYLUS 5 * NEW *
6369	ONBEKEND ARTIKEL (FAH383)
6369	ORTOFON ALL-ROUND F/FF I/II
6369	ORTOFON ALL ROUND F/FF I/II
6370	ELAC D-795 E
6371	ORTOFON STYLUS 20 (NEW)
6372	SHURE N-105 ED
6373	STYLUS FOR 2283/2288/2380
6373	78 RPM FOR 2283, 2288, 2380
6374	A.K.G. X-6 R
6374	A.K.G. X-6 E
6375	ELAC D-791
6376	ORTOFON ALLROUND FF-SERIES
6376	ORTOFON ALLROUND FF-E SER.
6377	VERVALLEN
6377	ELAC D-793 E
6378	AUDIO TECHNICA ATN-91 78-RPM
6379	DUAL DN-34 TBV MMD-340/345
6380	PHILIPS GP-350
6381	PHILIPS GP-351
6382	STANTON D-71 EE (L-720 EE)
6383	ELAC D-355-17
6383	ELAC D-355 E
6384	ELAC D-455-12
6384	ELAC D-455-E
6385	ELAC D-555-12
6385	ELAC D-555 E
6386	ELAC D-655 D-4
6387	PHILIPS GP-406 III
6388	PHILIPS GP-412 III
6389	PHILIPS GP-420 III
6390	STANTON D-6800 EL
6391	AUDIO TECHNICA ATN-10 G
6392	SHURE N-70 BX
6393	AUDIO TECHNICA ATN-13 E
6394	AUDIO TECHNICA ATN-360 YELLOW
6395	AUDIO TECHNICA ATN-361 GREEN
6396	AUDIO TECHNICA ATN-362 BLUE
6397	AUDIO TECHNICA ATN-14 EA
6398	AUDIO TECHNICA ATN-102 P
6399	ORTOFON STYLUS 15 NEW
6400	NIVICO DT-55 ELIP. BLUE/GUARD
6400	NIVICO DT-55 SHIBATA TIP
6401	SHURE N-97 LT HYP.ELLIPT. RED
6402	ASTATIC N4-2S 78RPM
6403	AUDIO TECHNICA ATN-3600L - DJ
6404	AUDIO TECHN. ATN-3472LC SHIBAT
6405	CONER RCS/RONETTE SC109
6406	NAALD VOOR PFAN P-132D
6407	SHURE VN-35 MR - SAS TIP
6408	AUDIO TECHN. ATN-3600 SHIBATA
6409	SHURE VN-45 MR - SAS TIP
6410	AUDIO TECHNICA ATN-95 HE BLUE
6411	ELAC D-793 SH - SAS TIP
6412	NATIONAL EPS-22 - SHIBATA
6413	PIONEER PNQ-1 - SHIBATA
6414	STANTON D-680 SHIBATA TYPE
6415	EMPIRE S-200 - SHIBATA STYLUS
6416	SHURE VN-15 (V-15 TII)-SAS TIP

TONAR No.	May be used as replacement for:
6417	EMPIRE S-2000-SHIBATA W/GUARD
6418	AUDIO TECHNICA ATN-95 SHIBATA
6419	ELAC DN-796 H - SHIBATA TIP
6420	SHURE V-15 TYPE V - MR
6421	ELAC D-796H - HYPER ELLIPTICAL
6422	SHURE N-91 HE - HYPER ELLIPT.
6423	AUDIO TECHNICA ATN-3492P
6424	SHURE N-75 ED II - SAS TIP
6425	SHURE V-15 TYPE V/MR - SAS
6426	SHURE N-91 ED - SAS TIP
6427	NATIONAL EPS-270 ED - SAS TIP
6428	SHURE N-95 ED - SAS TIP
6429	NATIONAL EPS-30 ES - SAS TIP
6430	SHURE V-15 TYPE V-X/MR
6431	AUDIO TECHNICA ATN-3482 P
6432	NATIONAL EPS-205CEX - SAS TIP
6433	AUDIO TECHNICA ATN-3472 EP
6434	NATIONAL EPS-205ED - SAS TIP
6435	SHURE V-15 TYPE V/xMR - SAS
6436	AUDIO TECHNICA ATN-3472 -78RPM
6437	AUDIO TECHNICA ATN-20 SS
6438	NATIONAL EPS-202 ED - SAS TIP
6439	AUDIO TECHNICA ATN-95 78 RPM
6440	AUDIO TECHNICA ATN-3472 SEP
6441	SHURE N-97 XE - SAS TIP
6442	SHURE N-110 MR - SHIBATA GR.CC
6443	STANTON D-72 E, D-73 E, L-727E
6444	COIN MACHINE
6445	SHURE VN-45 HE - HYPER ELLIPT.
6446	SIGNET TKN-22 STYLUS ELLIPT.
6447	STANTON 881-S SHIBATA TIP
6448	STANTON 881-S - D-SAS TIP
6449	NATIONAL EPS-270 HYPER ELL.
6450	SHURE VN-45 MR - SHIBATA TIP
6451	NATIONAL EPS-24 CS HYPER ELL.
6452	STANTON 681 EEE - HYPER ELLIPT
6453	SHURE V-15 III VN-35 HYPER ELL
6454	SHURE N-110 D-SAS TIP
6455	STANTON 881-S MK II - SHIBATA
6456	AUDIO TECHNICA ATN-3472 P
6457	AUDIO TECH. ATN-3600L-NO LOGO
6458	GOLDRING G-920 HYPEL
6459	TONAR STEEL NEEDLE V.SOFT TONE
6460	TONAR STEEL NEEDLES SOFT TONE
6461	TONAR STEEL NEEDLES MED-LOUD
6462	TONAR STEEL NEEDLES LOUD TONE
6463	TONAR STEEL NEEDLES VERY LOUD
6464	ASTATIC POWERPOINT 81T 89T
6465	ASTATIC POWERPOINT 81T; 89T
6466	PHILIPS GP-406 MK III
6467	DENON DL-107 STYLUS
6468	PHILIPS GP-412 MK III
6469	ORTOFON OM-SERIES SHIBATA
6470	AUDIO TECHNICA ATN-3472 HYPEL
6471	A.D.C. RS-Q 30 ELLIPT.
6472	SHURE N-97 HE SHIBATA
6473	A.D.C. XLM - SHIBATA
6474	SHURE VN-5 MR - HYPER ELLIPT.
6475	AUDIO TECHNICA ATN-14 SA-SHIBA
6476	ORTOFON D-30 E MKII SHIBATA
6479	SHURE VN-5 X/MR HYPER ELLIPT

tonar

specialist in styli, cartridges and accessories for vinyl

www.tonar.eu



styli & cartridges



sound enhancement



turntable essentials



cleaning accessories



tonar

specialist in styli, cartridges and accessories for vinyl
www.tonar.eu

Since 1954, Tonar has become the specialist for phonograph styli, cartridges and accessories for your turntable and vinyl collection. Whether you belong to the new generation of vinyl lovers, or are already an experienced analogue High End HiFi enthusiast, our aim is to provide you with all essential tools necessary to fully enjoy your record collection.

While the concept of the record player is old, the means to enjoy analogue audio stay up-to-date. As we speak, new innovations are developed to improve every aspect of the turntable as well as the quality of vinyl records. Yet, with our longstanding experience, we are also committed to keep vintage parts and technologies available.

Originally, Tonar was founded as an O.E.M supplier, specializing in the field of synthetic sapphire products, such as bearings for watches, gas meters and other instruments. These parts were sold to industrial users. Soon a phonograph cartridge manufacturer contacted us to purchase sapphire tips for their phonograph needles. This was the first step into what is currently our core business – replacement styli and cartridges for record players.

Tonar now boasts a huge collection of phonograph replacement needles, original needles, phonograph cartridges and accessories for vinyl. Our current line consists of more than 3000 replacement needles and original needles, as well as more than 1500 different types of phonograph cartridges. We offer special shape cartridges for old record players where only one cartridge model will fit, as well as standard 1/2 inch mount cartridges, T4P-plug-in cartridges, crystal, ceramic, moving magnet, induced magnet, moving iron and moving coil type cartridges. Our cartridges and styli are not only used in hi-fi record players but also in 78 RPM Pathe-phone's, vintage record players and juke boxes.

As we share a passion for analogue sound reproduction, Tonar tries to keep supplying you with every item you may require to bring or keep your HiFi record player up and running, whether it be a stylus, a cartridge, a new turntable belt or even many other original or replacement parts that you require in order to enjoy listening to your vinyl records. You will find many examples of these products in this leaflet which only barely touches the surface of our complete assortment.

*More than
3000 different
phonograph styli
available!*

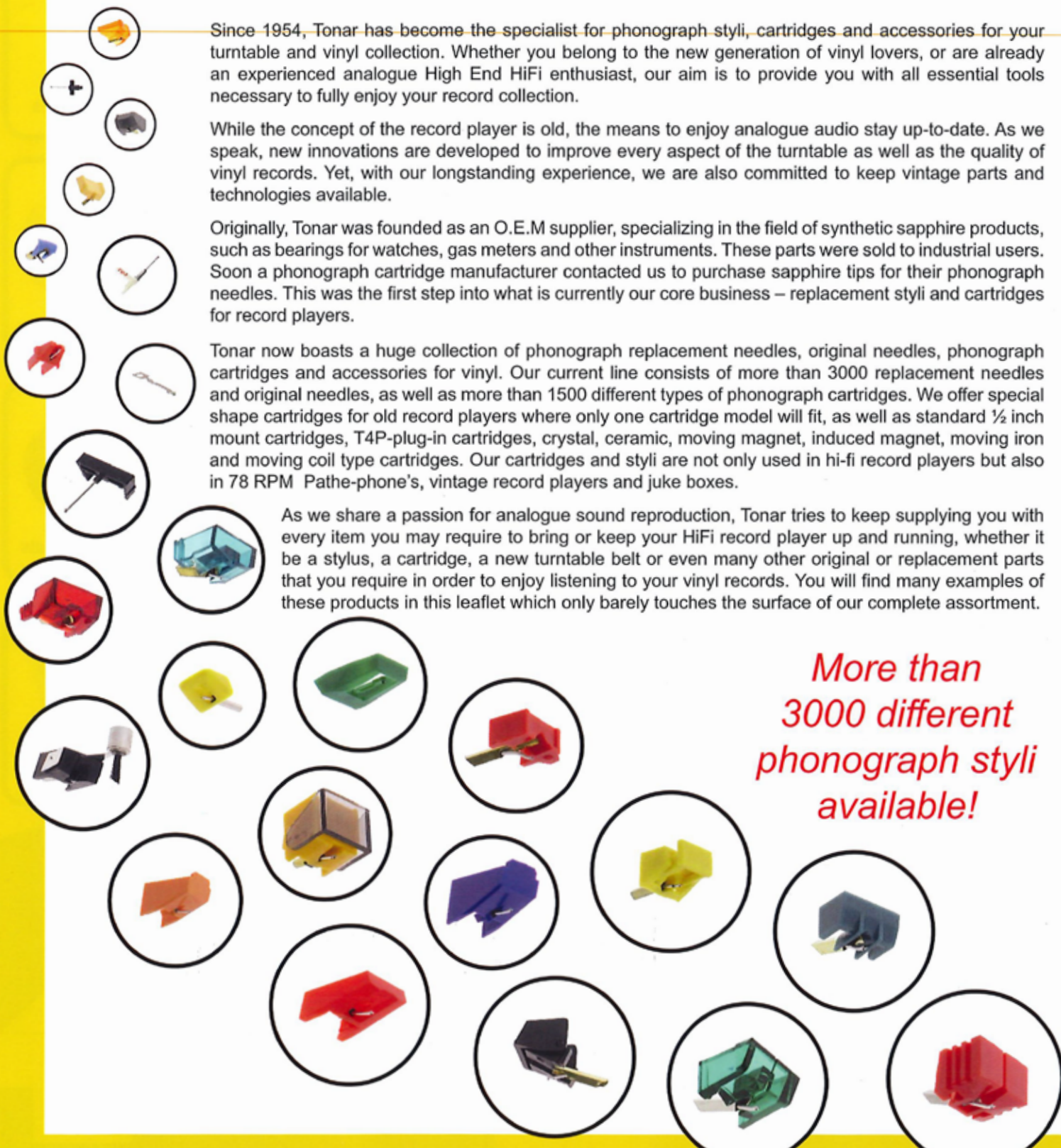

tonar

Vinyl Cleaning Essentials

When playing a record or even when taking the record out of its sleeve, it becomes static. This is because the surface of a vinyl record is not conductive and any static charge that develops remains. A static record attracts lots of dust and (pet) hairs, which not only affects the sound quality, but ultimately degrades the life of your vinyl collection, or damages the stylus of your record player. Tonar offers various easy-to-use tools to keep your valuable vinyl collection dust free, extending the life of your favorite recordings.

3180 – Tonar Nostatic Brush (carbon fibres)



The Tonar Nostatic Brush contains more than one million ultra fine carbon fibre bristles. The cross section of these bristles is so small that they can easily get into all the nooks and crannies of the record groove. Because the carbon fibre conducts electricity, it takes away all the static to earth via the metal handle when holding the brush. After the dust lies loose in the groove, the next set of bristles can easily pick them up and remove them from the groove.

3434 – Tonar Classic Brush (velvet)



The Tonar Classic Brush is manufactured using a very soft long fibre velvet, especially selected for this purpose. The velvet reaches deep into the grooves and removes even the finest dust particles. The brush itself can easily be cleaned using the two foam rubber scrapers located on both sides of the plastic brush base.

4365 – Tonar Dustaway (velvet + carbon fibres)



This state-of-the-art Hi-Fi record cleaning brush combines the properties of the Tonar Classic brush and the Nostatic brush into one brush! The center part of the brush is made of ultra-fine pole high quality velvet. This velvet is flanked on both sides by a thick layer of very fine carbon fibres. The carbon fibres remove the static from the record so the dust comes loose and can be easily picked up by the velvet centre brush even from deep in the grooves. A small tooth-brush is included to easily clean the dust off the velvet after use.

5973 – Tonar Tacky Cleaner (rolling cleaner)



The Tonar Tacky Cleaner is a record cleaner featuring a roll made out of silicone rubber. The property of this rubber is that it is sticky. When rolling the cleaner over the record while applying a little pressure, the rubber will take the shape of the groove and all dust particles in the groove will stick to the rolling cleaner and be removed in that way. When the roll has become dusty simply wash it under tap water using a little hand soap. The dust will easily be rinsed off. After drying the roll with lint free paper, it will become just as sticky as when it was new. There is no danger that you will damage the label when rolling over the label.

4475 – Tonar Nostatic Arm



The Nostatic Arm is the modern version of the formerly well known "Dust Bug" by Cecil Watts. The Nostatic arm incorporates a carbon fibre brush that removes the static charge from the record during playback, and at the same time picks up the loose dust before the stylus reaches that part of the record. The Nostatic arm has an earth wire which is connected to the earth of the record player or the amplifier. The height can easily be adjusted to suit most record players. It also has a sliding weight in order to adjust the "dusting force" of the brush.

4272 – Tonar Dust Jockey (velvet + carbon fibres)



The Tonar Dust Jockey combines the very best ultra-fine pole velvet available on the market with two rows of carbon fibres on both sides of the velvet. The carbon fibres remove the static charge and then the velvet can easily pick up the loose dust from the record. A small tooth-brush is included to easily clean the dust off the velvet after use. This ultimate brush is simply a must for serious vinyl fans and DJs.



tonar

Vinyl Washing Essentials

Records do not only gather dust. Air pollution from the traffic outside, cooking fat, grease and tobacco smoke causes a tough film to form on the surface of the record. Sometimes even molds and fungi are present if the records have been stored for a prolonged period in a humid environment. The stylus tracking the record will scrape part of this dirt off the groove and this causes a thick build-up of grime on the stylus. Ultimately, this will result in complete miss tracking or groove skipping with permanent damage to your stylus and records. Tonar offers effective solutions to keep your precious record collection impeccable.

5938 – Tonar Wetgoat



When cleaning records with fluid, a special fluid resistant brush is required. The Tonar Wetgoat is made of the finest natural goat hair which has the perfect shape to enter deep into the grooves and clean them thoroughly. Goats hair is known for its ultra-soft qualities, and demonstrable anti-static properties.

5379 – Tonar Woodgoat



The Tonar Woodgoat is a premium record brush that features two rows of real goats hair. Goat hair is used as it is fine, soft and perfect for use when wet, making this brush ideal for any fluid based cleaning liquid you use on your records. The anti-static property of goats hair makes this brush also perfect to clean dusty records without liquid.

5553 – Tonar Top Tip stylus cleaning kit



The Tonar Top Tip is a powerful cleaning solution that will detach all the dirt and tough grime that your stylus collects from the record during playback. The kit contains the Tonar Top Tip cleaning and lubricating liquid and a Tonar Clean-Tip carbon fibre stylus cleaning brush.

4250 – Tonar Clean-Tip (carbon fibre stylus brush only)

QS-Tonar Vinyl Cleaning Fluid

QS-TONAR vinyl cleaning fluid can be used in all record cleaning machines that are currently on the market and is only suitable for vinyl records. Important: do not use with old 78 RPM shellac records as the liquid may do irreparable damage. Now what is so special about the QS-TONAR vinyl cleaner compared to similar looking competing products on the market?

QS-TONAR liquid has an extremely low surface tension

Only because of this reason QS-TONAR liquid can penetrate right to the bottom of the groove. Other fluids

while they seem to penetrate, actually just lie on top of the record surface. Only QS-TONAR liquid cleaner soaks the dust, dirt, air pollution, residue from previously used cleaners, fatty deposits remaining from the original record pressing process, even fungi and moulds caused by records having been stored in humid conditions etc. QS-TONAR liquid detaches all of the before mentioned dirt from the walls of the groove after which the brushes in the machine can easily wipe the groove completely clean. The amount of residue remaining in the groove is negligible – this contrary to other

liquids currently on the market. QS-TONAR liquid is much more volatile than other liquids reducing the drying time of the record to a minimum. QS-TONAR liquid also has another additive causing the dirt to remain floating in the liquid rather than settling back at the bottom of the groove. QS-TONAR liquid is available in three formats: as a 0.5 litre pump spray flask for spraying onto records for small cleaning jobs, as a 1 litre bottle and as a 5 litre tank for big users with washing machines of all types



3514 – QS-Tonar Vinyl cleaner
0.5 Litre pump-spray flask



3503 – QS-Tonar Vinyl cleaner
1 Litre bottle



4262 – QS-Tonar Vinyl cleaner
5 Litre tank

tonar

Tonar *Knosti* Disco-Antistat Vinyl Washing Machines

No matter how much you spend on the complete set-up of your analogue sound system, it is ultimately the vinyl itself that is the source of the sound that you hear from your speakers. Therefore, effective and proper cleaning of your records is vital. The Tonar *Knosti* Disco-Antistat is a unique manual vinyl washing system that cleans even the dirtiest records and prevents static charges. Every groove of your precious records will be cleaned thoroughly. The Disco-Antistat is easy-to-use and doesn't cost a fortune by comparison with noisy vacuum record cleaning machines.

5412 – Tonar *Knosti* Disco-Antistat Generation II



The Tonar *Knosti* Disco-Antistat Generation II is the new and improved manual vinyl washing machine. What are the new features?

NEW: The washing cabinet has practical arms to lock the axis in place. This avoids spilling of the cleaning liquid while rotating the record.

NEW: The included rubber seal in the protective record clamps prevents liquid to reach the label.

NEW: Using the crank-arm, you can easily rotate the record, without getting the cleaning liquid on your hands.



How the Disco-Antistat works:

The Tonar *Knosti* Disco-Antistat makes it fun and easy to clean your record collection. Each set includes a rectangular washing cabinet, a clamp to protect the label, 1 litre of special vinyl cleaning fluid, a drying rack and a funnel to put the fluid back into the bottle after use.

The washing tub is filled with vinyl cleaning fluid up to the top of the goats hair brushes that are pre-mounted inside.

Next, a dirty record is placed between the two halves of the record clamp and screwed tight. A rubber seal inside the clamp prevents moisture from reaching the label. Protruding from the outer sides of the clamp are two pegs, which sit in slots atop the Tonar *Knosti* machine. The new Generation II Disco-Antistat includes two arms to lock the record in the slots.

The vinyl is then rotated by hand, or by using the spindle that is included in the Generation II Disco-Antistat. It's recommended to rotate the record 5 to 10 times through the bath in both directions.

As the record passes through the washing tub, two sets of brushes clean each side of the record. The brushes are made using the finest natural goats hair, which has the unique property to enter deep into the grooves and the hair is not attacked by the fluid.

Once you're happy with the result, simply remove the record from the protective clamps, and place your clean record on the rack to dry. When cleaning is complete, pour your used cleaning fluid from the washing tub back into your cleaning fluid bottle for re-use using the funnel and filter provided.

A regular washing of your records at least once a year can increase your listening pleasure dramatically.

3508 – Tonar *Knosti* Disco-Antistat



The Tonar *Knosti* Disco-Antistat is the classic manual vinyl washing machine as successfully produced since 1978.

The Disco-Antistat set includes:

- Washing cabinet with integrated brushes made out of goats hair.
- Label protecting clamshell with axis for 12 inch LPs, 10 inch Long Play records and 7 inch 45 RPM Singles and EP records.
- A funnel with filters is provided to allow re-use of your cleaning fluid if desired.
- Drip-dry rack with catch basin for up to 15 records of any size.
- 1 liter *Knosti* anti-static cleaning fluid

New records as well as old ones from the attic..

The Disco-Antistat makes them clean and anti-static!



tonar

Record Sleeves

Protect your fragile vinyl records and record albums from dust, air pollution, tobacco smoke, fungi and other contaminants with Tonar anti-static record sleeves



record sleeves



tonar

Record Sleeves

Dust and air pollution are the biggest enemies of your fragile vinyl records and your record album covers. Pollution from cooking grease, smoking and outside pollution (like exhaust fumes from cars) causes a sticky aggressive film to build up on your records. This sticky film attracts and grabs even more dust and spoils the sound on playback. It is very important to protect your vinyl and keep your records clean. Good quality anti-static dust free record inner sleeves and sturdy outer sleeves will protect your records and albums from these influences.

Tonar Inner Sleeves



The Tonar Nostatic Inner Sleeves are made of 2 layers 40 micron thick HDPE super anti-static plastic. The Nostatic sleeves are available in three sizes: 12 inch, 10 inch and 7 inch. So there is a Tonar Nostatic sleeve available for every format whether 12 inch LP, 10 inch Long play and 78 RPM Shellac and 7 inch 45 RPM and EP records.

available sizes



12 inch

5961 – Tonar Nostatic sleeves for 12 inch (30cm) LP records (50 sleeves per package).



10 inch

5315 – Tonar Nostatic sleeves for 10 inch Long Play records as well as 78 RPM shellac records. Contains 50 sleeves per package.



7 inch

5983 – Tonar Nostatic sleeves for 7 inch (17.8 cm) 45 RPM records. Contains 50 sleeves per package.

Tonar Plastipap

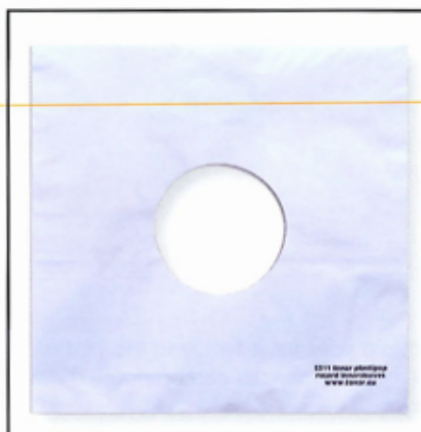

Tonar's best solution is the already world famous 'Plastipap inner sleeve'. This very strong sleeve consists of 4 layers with 40 micron thick HDPE super anti-static plastic and two layers of 100% sealed paper reinforcements in between. This product is currently only available for 12 inch LP records.



5311 – Tonar Plastipap inner sleeves Contains 25 pieces per package.

Tonar Outer Sleeves



Your valuable record albums will easily get soiled due to air pollution and handling with (greasy) fingers. Use the Tonar heavy duty outer sleeves made from Crystal Clear 125 micron thick PP plastic. The Tonar outer sleeves are also available in three sizes for 12 inch LP, 10 inch Long play or 78 RPM Shellac and 7 inch 45 RPM or EP records.

available sizes

5979 – Tonar 12 inch heavy duty outer sleeves for LP records. Contains 25 sleeves per package.



5313 – Tonar 10 inch heavy duty outer sleeves for LP records as well as 78 RPM shellac records. Contains 25 sleeves per package.



5317 – Tonar 7 inch heavy duty outer sleeves for 45 RPM records. Contains 50 sleeves per package.



The best solution to store and preserve your record collection

visit our website: www.tonar.eu



tonar

Record Weights and Clamps

There are two distinct advantages to using a record clamp or weight on your turntable. First, they help to temporarily flatten warped records during playback. Many of the older records are either warped from the time they were pressed or have become warped in time due to bad storage. A warped record causes enormous problems for the cartridge and stylus to track the groove properly. Secondly, vinyl records vibrate along with the music as the stylus traces the groove. This can cause internal resonances. By using a record clamp or a weight, warped records will be flattened and the sound quality will be improved.

5464 – Tonar misty clear clamp



5290 – Tonar misty yellow clamp



5470 – Tonar misty black clamp



The aesthetically designed Tonar clamps couple your vinyl tightly to the platter. This will help to temporarily flatten out any warps during play-back and assures that internal resonances can be drained away from the stylus. The clamps are available in different colors, to match every record player.

5478 – Tonar misty green clamp



5475 – Tonar misty red clamp



5467 – Tonar misty blue clamp



*The Tonar clamps are available in different colors,
to match every record player*

4611 – Tonar Record Weight
Black (760 grams)



Tonar Record Weights

By using a Tonar record weight, the record will be pressed flat against the turntable platter causing it to become temporarily less warped during playback and making good contact with the platter. The weights are either nickle colour or covered with black enamel and a felt cushion on the base to protect the label of the record against scratching. Dimensions: 78 mm diameter x 25 mm. Caution: Please ensure that the platter bearing of your turntable is able to accept the additional weight of 760 grams. If in any doubt please consult your record player instructions or your dealer.

5964 – Tonar Record Weight
Nickle (760 grams)



Turntable Mats

Acoustic feedback is one of the big problems when playing records. It occurs when sound vibrations from your loud speakers are picked up by your turntable, amplified, and then sent out to the speakers again. The same information is reproduced by the cartridge with a very slight time difference. This results in a big loss of detail and clarity and makes the sound 'muddy'. Tonar has developed turntable mats that reduce acoustic feedback, thus maintaining separation and detail. The mats isolate the record from the turntable platter and absorb unwanted vibrations. That is why using turntable mats really matters!

Tonar Turntable Mats

5391 – Tonar Crystal Mat

Turntable Mats Matter!

The Tonar turntable mats have been developed through experiments with different materials. Apart from absorbing and dampening unwanted vibrations, the mats have their own effect to enhance the sound. Some audiophiles even combine different materials as a 'sandwich' to create even better results.

Tonar offers a large selection of commercially manufactured mats made from various materials for you to be able to experiment yourself and to find the best mat for the different recordings in your collection. All Tonar mats (except the Nostatic Mat and the Leather Mat) have a depressed centre section, allowing space for the thicker record label so the vinyl record can lay perfectly flat on the mat. All mats have a diameter of 295 mm, except for the Rubber Mat (diameter: 298 mm). Now start testing your own combination of mats to fit your musical taste and improve the quality of the sound!

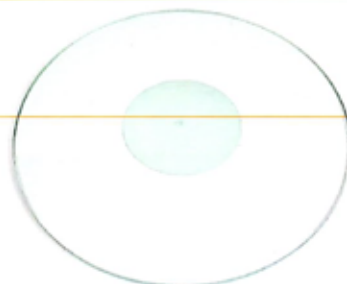

This luxury mat is made of pure glass and enhances the detail of the various instruments or vocals on your records. It is lighter and harder than aluminium and produces a crystal clear sound.

5972 – Tonar Pure Cork turntable mat

5312 – Tonar Nostatic Mat II Improved

5974 – Tonar Cork & Rubber mixture turntable mat



Cork material is known to dampen and absorb unwanted vibrations. The Tonar cork mat works very well on most turntables, due to its non-resonant properties.

The Tonar Nostatic mat is a mat made of industrial felt mixed with carbon fibres. The carbon fibres release the static charge from the record and conduct it to earth using the metal spindle of the record player.

Both cork and rubber are known to dampen and absorb unwanted vibrations. The Tonar composite cork/rubber mat works very well on many turntables, particularly on steel and lightweight turntable platters, due to its highly non-resonant properties.

5978 – Tonar Black Natural leather turntable mat

5976 – Tonar Pure White Perspex mat

5988 – Tonar Rubber turntable mat



The Tonar Black Leather Platter Mat is a premium mat made from real leather/suede. With its luxury look, this leather mat dampens and absorbs unwanted vibrations.

Perspex is a kind of acrylic. The mat enhances in particular the higher frequencies. Also in terms of aesthetics, this white coloured mat can perfectly match your modern turntable.

Sometimes, the original rubber mat on the turntable has become dirty or even has chemically decomposed. Tonar offers a fresh new rubber turntable mat to replace the old one.



tonar

Turntable Essentials

Everyone who puts on a vinyl record, will soon realize that a turntable is actually an engineering work of art and a musical instrument itself. Perhaps it is the beauty of analogue audio, that as a user, you have almost every possibility to fully fine-tune your equipment. Tonar offers various affordable tools that are not only effective, but also easy-to-use and will benefit your listening pleasure.

5944 – The Q UP automatic tonearm lifter



Using the Q UP tonearm lifter, extends the life of your stylus

The Q UP is a high precision device that safely lifts your tonearm at the end of the record. This will extend the life of your stylus significantly. The Q UP can be installed in minutes, without tools, and is designed to fit on most manual turntables. The Q UP can be configured for a variety of tonearm heights, thicknesses and shapes. This unique automatic tonearm lifter only interacts with the tonearm at the end of record and does not adversely effect the tonal quality of your system in any way. Thanks to the Q UP, you don't need to worry about getting distracted or falling asleep while you play your records.



5462 – Tonar Ecolevel Yellow



Tonar Turntable Levels

For the best sound reproduction your turntable has to be installed precisely horizontal. These simple but effective levels from Tonar will tell you if your turntable is mounted on a flat surface for optimal performance.

5469 – Tonar Luxlevel Black



4189 – Tonar Vinyline MC/MM Pre-Amplifier



The Tonar Vinyline phono MM/MC Pre-Amplifier is a very affordable solution to connect High End phonograph cartridges whether moving magnet (MM) or moving coil (MC) to the AUX port of your amplifier. A switch on the back switches it from high output MM to low output MC mode.

Specifications:

Input (MM):	47 K Ω / 100 p.Farad
Input (MC):	100 Ω / 100 p.Farad
Output MM:	200 mV/1 KHz at 5mV/1KHz MM
Output MC:	200 mV/1 KHz at 0.45 mV/1KHz MC
Gain:	MM: 32 dB / MC: 53 dB
Noise floor:	MM: -88 dB / MC: -79 dB
THD:	0.005%
RIAA curve acc.:	20 – 20.000 Hz / max: 0.5 dB
Power supply:	16V/200 mA AC



Turntable Essentials

Tonar Trackurate digital stylus force gauge



4293 – Tonar Trackurate (yellow)



3583 – Tonar Professional alignment protractor



This Protractor is a unique alignment gauge which allows you to check the tone arm geometry and to install the cartridge ideally aligned to keep distortion to a minimum. It offers every essential information in order to install and align your cartridge professionally. English and German instructions included. A must for the very serious Hi-Fi enthusiast.

3193 – Tonar No Rumble Pads



These pads, supplied in sets of 8 pieces, isolate your audio equipment from vibrations in the room. For turntables, speakers, and any other delicate systems. The No Rumble Pads are an effective solution for reducing rumble and vibration at the source before it passes through your system.

Getting the most out of any turntable requires an accurate vertical tracking force setting. Every cartridge on the market has a preferred tracking force range recommended by the manufacturer. Depending on the arm used you may have to be lower in the range or higher in the range. The Tonar Trackurate helps you adjust the tracking force very accurately. The easy to use Tonar Trackurate is the one case where digital makes more sense when it comes to fine-tuning your analog.

The Tonar Trackurate includes a soft case, batteries (AG12 button cell) and a weight to calibrate.



4367 – Tonar Trackurate (black)

Specifications:

Capacity: 0 - 5 grams
Accuracy: 0.01 grams
Weighing modes: g; oz; ozt; TL; ct

4208 – Tonar simple alignment protractor



A proper alignment of your cartridge will help you to enjoy the best possible sound. The Tonar Simple Alignment Protractor is an inexpensive device that allows you to properly mount and adjust your cartridge stylus for optimal groove tracking and music retrieval. The mirror makes it easy to check the azimuth of the cantilever.

5953 – Tonar 45 RPM adapter aluminum



The Tonar 45-rpm adapter is made of solid aluminum and is perfectly centered so you can optimally enjoy your favorite singles. It fits all modern turntables and can also be used on older turntables.

4614 – Tonar Anti-Skate Weight



Using an Anti-Skate Weight helps to bring a perfect amount of counter-drag on the tonearm, reducing the inclination for the arm to 'skip' or 'skate' across the record.

Tonar Turntable Belts



Worn and stretched belts are the largest contributor to turntable speed fluctuations which destroy your sound-stage. Tonar can supply replacement belts for almost any brand and model turntable.



tonar

Stroboscope Discs

Records over the years have been cut at many different speeds. Originally they were cut at '78 RPM' or speeds around that value. Later the industry decided to cut all records at 33 1/3 or 45 RPM. For speech recordings even slower speeds were used in order to increase the amount of time recorded on each side of the record: 16 2/3 and 8 1/3 RPM. Of course you want to enjoy a recording at the correct tempo, but sometimes record players do not play at the proper speed and need adjusting. For that purpose Tonar now offers a total of three different Stroboscope Discs.

The detailed and easy-to-use Tonar Stroboscope Discs are created in three versions to measure different ranges of speed:

- A simple Tonar part 5468 Aluminium stroboscope disc of 10 cm diameter with the speeds 8 1/3, 16 2/3, 33 1/3, 45 and 78 RPM.
- For more accurate use we also offer Tonar part 5463 12 inch yellow acrylic stroboscope also with the speeds 8 1/3, 16 2/3, 33 1/3, 45 and 78 RPM.
- Finally for the 78 RPM shellac record collector we offer a very special Tonar part 5466 – 12 inch yellow acrylic Stroboscope disc offering all speeds: 8 1/3; 16 2/3; 33 1/3; 45; 70; 72; 73; 75; 76; 78; 80; 81; 83; 85; 87; 90 RPM. The reason for this is that in the beginning of the record industry every record manufacturer recorded at their own speed. This is apparent from the old Pathé phones which even had a speed control. As modern players offer a strict 78 RPM speed many of the really old shellac records sound odd because they are playing at either a too slow speed (tones are too low) or a too fast speed (tones are too high).

Enjoy your records at the proper speed

How to use the Tonar Stroboscope Discs

If you have a record player with pitch (speed) control like a DJ-record player you can adjust the speed. Put the record on the player at 78 RPM and listen, then adjust the speed up or down until the record sounds normal. Then replace the record with the Stroboscope and read the speed that you selected and make a note of this on the album. Next time you want to play the record, first put the stroboscope to adjust to the proper speed setting and then play the record immediately at the proper speed.

5463 – Stroboscope 30 cm diameter Deluxe

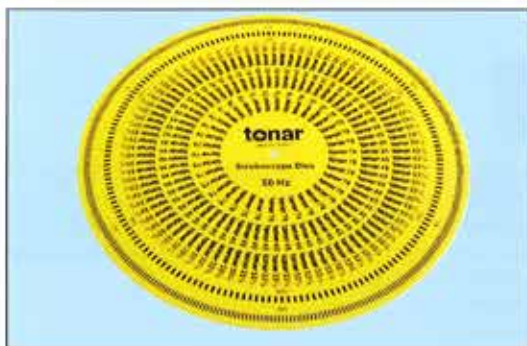

Speeds: 8 1/3; 16 2/3; 33 1/3; 45; 78 RPM.

5466 – 12 inch Yellow Acrylic Stroboscope Disc for all speeds

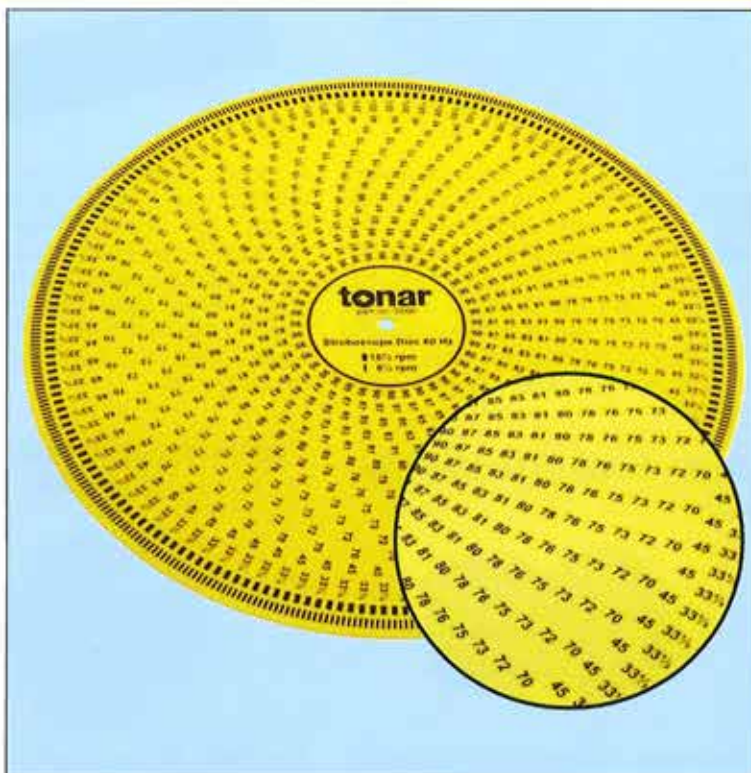

This Tonar Stroboscope Disc offers all speeds: 8 1/3; 16 2/3; 33 1/3; 45; 70; 72; 73; 75; 76; 78; 80; 81; 83; 85; 87; 90 RPM.
The ultimate stroboscope disc for the 78 RPM shellac record collector!

5468 – Aluminium Stroboscope 10 cm diameter Standard



Speeds: 8 1/3; 16 2/3; 33 1/3; 45; 78 RPM.

Tonar Stroboscopes, a must for every record collector!

tonar

High End Head Shells and Wiring

Most turntables are supplied with a standard entry level head shell. The sound quality can be strongly improved by using a so-called "high end shell". Some shells have the possibility to adjust the pitch of the shell axial wise, as compared to the tone arm. This allows an exact vertical mounting of the cartridge and stylus tip onto the record. Further improvements can be made by using high quality head shell lead wires.

Tonar TopQ High End head shells

Tonar TopQ High End head shells come in two versions, one with a removable arm lifter and one with a fixed arm lifter. Both models have the possibility to adjust the pitch of the shell axial wise, as compared to the tone arm. This allows an exact vertical mounting of the cartridge and stylus tip onto the record. The finest quality OFC (Oxygen Free Copper) lead wires are used in the Tonar TopQ head shells. Both models are available in black or in silver/bronze. All Tonar TopQ models have a SME type connector for use on S-shaped tone arms.



4420 – Tonar TopQ head shell (black) removable arm lifter



5330 – Tonar TopQ head shell (black) fixed arm lifter



5907 – Tonar TopQ head shell (silver/bronze) removable arm lifter



5386 – Tonar TopQ head shell (silver/bronze) fixed arm lifter

Tonar SME type High End head shells

Light weight entry level shells suitable for most tone arms with SME type connector.



3197 – Tonar SME type shell (black)



3196 – Tonar SME type shell (silver)

5405 – Tonar Cherry Wood head shell



The Tonar head shell made of cherry wood, is a high quality audiophile head shell and provides an elegant solution with a variety of cartridges. It has a SME style locking collar (as found on most tone arms with removable head shells). The connectors are gold plated and the included head shell leads are silver plated.

Lenco Head Shell 5407 (silver) – 5408 (black)

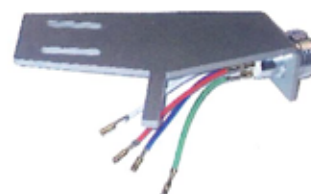

There are many vintage Lenco record players on the market that only require a head shell. The original shell is no longer available, but now there is a high quality Tonar replacement model. Fits Lenco players B52; B55; L72; L75, L76 and L78. Includes a set of mounting plates.



4612 – Tonar High End Tone arm wires sets



The Tonar tone arm wire sets are made of 99.99% Oxygen free copper and are available in a length of 53 cm with gold plated terminal pin lugs on one side.

5970 – Tonar Shell wire CU-litz (OFC copper)



Our finest Oxygen Free Copper (OFC) head shell wires with gold plated clips as used in the Tonar TopQ shells.

4613 – Tonar Gold Plate terminal pins for cartridges



The gold plated pins enhance a low resistance electrical connection with the wires, because they cannot oxidize.

high end head shells and wiring

tonar

HiFi Cartridges 1/2 Inch Mounting

Tonar Flip Series Cartridges 1/2 Inch Mounting

The cartridge is perhaps the most important component of your whole audio system. The cartridge converts the vibrations of the stylus into audio signals, which are amplified in the rest of your system. Hence, the cartridge determines largely the quality of the sound that you hear. What doesn't go in, doesn't come out. For that matter, selecting a cartridge is vital for your listening pleasure.

In order to provide excellent sound reproduction at a modest price, Tonar has launched the Tonar Flip-series of cartridges with high end models available to suit all budgets. The Tonar 1/2 inch standard mount Flip cartridges are now also available with a hyper-elliptical or with a Shibata stylus tip. These cartridges offer excellent sound reproduction in the higher frequency ranges. The use of the Shibata tip also reduces record and stylus wear to the absolute minimum.

9511 – Tonar C - Flip Spherical tip



Output 3.5 mV at 1 KHz 5.0 cm/sec
Channel balance within 2.5 dB at 1 KHz
Channel separation more than 18 dB at 1 KHz
Load impedance 47 KΩ
Load capacitance 100 pF
Static compliance 12 x 10⁻⁶ cm/dyne
Dynamic compliance 5 x 10⁻⁶ cm/dyne
Tracking force 1.5 – 2.5 gram (opt. 2.0 gr.)
Stylus tip radius 0.6 mil spherical
Stylus tip material bonded diamond
Tip diameter 0.3 mm
Cantilever carbon fibre
Cartridge weight 5.0 grams ± 0.5 gr.
Frequency response 20 – 20.000 Hz. ± 3 dB

9513 – Tonar E - Flip Elliptical tip



Output 3.5 mV at 1 KHz 5.0 cm/sec
Channel balance within 2.5 dB at 1 KHz
Channel separation more than 18 dB at 1 KHz
Load impedance 47 KΩ
Load capacitance 100 pF
Static compliance 12 x 10⁻⁶ cm/dyne
Dynamic compliance 5 x 10⁻⁶ cm/dyne
Tracking force 1.5 – 2.5 gram (opt. 2.0 gr.)
Stylus tip radius 0.3 x 0.7 mil elliptical
Stylus tip material bonded diamond
Tip diameter 0.3 mm
Cantilever aluminium
Cartridge weight 5.0 grams ± 0.5 gr.
Frequency response 20 – 20.000 Hz. ± 3 dB

9583 – Tonar H - Flip Hyper Elliptical tip



Output 3.5 mV at 1 KHz 5.0 cm/sec
Channel balance within 1.5 dB at 1 KHz
Channel separation more than 22 dB at 1 KHz
Load impedance 47 KΩ
Load capacitance 100 pF
Static compliance 12 x 10⁻⁶ cm/dyne
Dynamic compliance 5 x 10⁻⁶ cm/dyne
Tracking force 1.5 – 2.0 gram (opt. 1.75 gr.)
Stylus tip radius 0.2 x 0.7 mil hyper elliptical
Stylus tip material bonded diamond
Tip diameter 0.25 mm
Cantilever aluminium pipe
Cartridge weight 5.0 grams ± 0.5 gr.
Frequency response 15 – 25.000 Hz. ± 2.5 dB

9586 – Tonar S - Flip Shibata tip



Output 3.5 mV at 1 KHz 5.0 cm/sec
Channel balance within 1.5 dB at 1 KHz
Channel separation more than 28 dB at 1 KHz
Load impedance 47 KΩ
Load capacitance 100 pF
Static compliance 12 x 10⁻⁶ cm/dyne
Dynamic compliance 5 x 10⁻⁶ cm/dyne
Tracking force 1.5 – 2.0 gram (opt. 1.50 gr.)
Stylus tip radius shibata - line contact
Stylus tip material bonded diamond
Tip diameter 0.25 mm
Cantilever aluminium pipe
Cartridge weight 5.0 grams ± 0.5 gr.
Frequency response 15 – 30.000 Hz. ± 2.5 dB

HiFi Cartridges T4P (Plug-In) Mounting

Tonar Plugger Series Cartridges T4P (Plug-In) Mounting

Once, T4P (plug in) was a very popular option for easily mounting and changing cartridges. The record players using this mounting standard have become more rare. Because of that, most cartridge manufacturers have discontinued producing T4P-type plug-in cartridges. Now Tonar has launched the Tonar Plugger series of T4P plug-in cartridges with high end models available again to suit all budgets. These T4P cartridges provide excellent sound reproduction at a modest price.

Very few cartridge manufacturers offer T4P cartridges with Hyper-Elliptical and/or Shibata tips. Tonar is happy to provide these models. These Tonar Plugger cartridges offer excellent sound reproduction in the higher frequency ranges. The use of the Shibata tip also reduces record and stylus wear to the absolute minimum.

9496 – Tonar C - Plugger Spherical tip



Output 5.0 mV at 1 KHz 5.0 cm/sec
Channel balance within 1.5 dB at 1 KHz
Channel separation more than 24 dB at 1 KHz
Load impedance 47 KΩ
Load capacitance 100 pF
Static compliance 12 x 10⁻⁶ cm/dyne
Dynamic compliance 5 x 10⁻⁶ cm/dyne
Tracking force 1.5 – 2.0 gram (opt. 1.75 gr.)
Stylus tip radius 0.6 mil spherical
Stylus tip material bonded diamond
Tip diameter 0.3 mm
Cantilever carbon fibre
Cartridge weight 5.0 grams ± 0.5 gr.
Frequency response 0 – 20.000 Hz. ± 2.5 dB

9540 – Tonar E - Plugger Elliptical tip



Output 5.0 mV at 1 KHz 5.0 cm/sec
Channel balance within 1.5 dB at 1 KHz
Channel separation more than 24 dB at 1 KHz
Load impedance 47 KΩ
Load capacitance 100 pF
Static compliance 12 x 10⁻⁶ cm/dyne
Dynamic compliance 5 x 10⁻⁶ cm/dyne
Tracking force 1.0 – 1.5 gram (opt. 1.50 gr.)
Stylus tip radius 0.3 x 0.7 mil elliptical
Stylus tip material bonded diamond
Tip diameter 0.3 mm
Cantilever aluminium pipe
Cartridge weight 5.0 grams ± 0.5 gr.
Frequency response 20 – 23.000 Hz. ± 2.5 dB

9588 – Tonar H - Plugger Hyper Elliptical tip



Output 5.0 mV at 1 KHz 5.0 cm/sec
Channel balance within 1.5 dB at 1 KHz
Channel separation more than 26 dB at 1 KHz
Load impedance 47 KΩ
Load capacitance 100 pF
Static compliance 12 x 10⁻⁶ cm/dyne
Dynamic compliance 5 x 10⁻⁶ cm/dyne
Tracking force 1.0 – 1.5 gram (opt. 1.50 gr.)
Stylus tip radius 0.2 x 0.7 mil hyper elliptical
Stylus tip material bonded diamond
Tip diameter 0.25 mm
Cantilever aluminium pipe
Cartridge weight 5.0 grams ± 0.5 gr.
Frequency response 15 – 25.000 Hz. ± 2.5 dB

9590 – Tonar S - Plugger Shibata tip



Output 5.0 mV at 1 KHz 5.0 cm/sec
Channel balance within 1.5 dB at 1 KHz
Channel separation more than 28 dB at 1 KHz
Load impedance 47 KΩ
Load capacitance 100 pF
Static compliance 12 x 10⁻⁶ cm/dyne
Dynamic compliance 5 x 10⁻⁶ cm/dyne
Tracking force 1.0 – 1.5 gram (opt. 1.50 gr.)
Stylus tip radius shibata - line contact
Stylus tip material bonded diamond
Tip diameter 0.25 mm
Cantilever aluminium pipe
Cartridge weight 5.0 grams ± 0.5 gr.
Frequency response 15 – 30.000 Hz. ± 2.5 dB

tonar

DJ Cartridges and Head Shells

2994 – Tonar Birdie DJ cartridge



DJ Birdie

The Tonar DJ Birdie is a great DJ cartridge at a modest price. The fluorescent tip makes it easy for the DJ to put the stylus in the desired part of the groove. Many jukebox collectors have also discovered this cartridge to replace their no-longer available original jukebox cartridges.

Cartridge weight	4.1 g
Stylus tip shape/radius	0.7 mil spherical diamond
Frequency characteristics	20-20,000 Hz +/- 4 dB
Output Voltage	5.0 mV (5 cm/sec)
Channel Separation	17 dB (1 KHz)
Channel balance	2.0 dB or less (1 KHz)
Compliance	3.5×10^{-4} cm/dyne
Stylus pressure	2.0 – 3.0 g (2.5 g opt)
Load resistance	47 K Ω
Stylus tip material	bonded diamond
Tip diameter	0.4 mm
Vertical tracking angle	20°
Recommended load resistance	47 k Ω
Recommended load capacitance	400 pF
Scratching	suitable for scratching
Cartridge mounting system	1/4 inch

2735 – Tonar Banana DJ cartridge



Banana

The Banana is Tonar's legendary yellow DJ cartridge, designed to meet the high demands of DJs. Its integrated design connecting directly to the SME-type tonearm connector, makes it very easy for the DJ to mount his cartridges on tour. The Tonar Banana provides the essential vitamins for your audience.

Cartridge weight	16.0 g
Stylus tip shape/radius	0.7 mil spherical diamond
Frequency characteristics	20-20,000 Hz
Output Voltage	5.0 mV (5 cm/sec)
Channel Separation	20 dB (1 KHz)
Channel balance	2.0 dB or less (1 KHz)
Dynamic compliance	8 μ m/mN
Stylus pressure	3.0 – 5.0 g (4.0 g opt.)
Load resistance	47 K Ω
Stylus tip material	bonded diamond
Vertical tracking angle	20°
FIM distortion	1.8%
DC resistance	600 Ω
Recommended load resistance	47 k Ω
Recommended load capacitance	400 pF
Scratching	suitable for scratching
Cartridge mounting system	for SME-type arm only
Tracking ability at 315 Hz lateral	70 μ m

2987 – Tonar Diabolic - E DJ cartridge



Diabolic E

The devil is in the detail! With its unique 8 millivolt output, the Diabolic-E is full of DJ power. Many audiophiles favour the Diabolic-E thanks to its sound quality and elliptical diamond stylus.

Cartridge weight	5.0 g
Stylus tip shape/radius	elliptical diamond
Frequency characteristics	20-24,000 Hz +/- 4 dB
Output Voltage	8.0 mV (5 cm/sec)
Channel Separation	18 dB (1 KHz)
Channel balance	2.0 dB or less (1 KHz)
Compliance	6.0×10^{-4} cm/dyne
Stylus pressure	4.0 – 5.0 g (4.5 g opt.)
Load resistance	47 K Ω
Stylus tip material	bonded diamond
Tip diameter	0.3 mm
Vertical tracking angle	20°
Recommended load resistance	47 k Ω
Recommended load capacitance	400 pF
Scratching	suitable for scratching
Cartridge mounting system	1/4 inch

Tonar DJ head shells



4601 – Tonar DJ head shell
(silver)



4602 – Tonar DJ head shell
(black)



4603 – Tonar DJ head shell
(silver)



4604 – Tonar DJ head shell
(black)

The best selling DJ head shells and general purpose shells. Made of high quality aluminum. For DJs that require a heavier tracking force, the head shells 4603 and 4604 also include a 2 gram and a 4 gram additional screw-on weight.





StylusTimer™



€24,95

Tonar no. 5241

BESCHERM UW PLATEN | HOUD UW GEBRUIKSTIJD BIJ | ZIE WANNEER UW NAALD MOET WORDEN VERVANGEN

- Nu kunt U eenvoudig het aantal luisteruren van Uw naald bijhouden.
- Bepaal nauwkeurig de inspeeltijd van Uw naald
- Bescherm Uw dierbare platencollectie tegen schade door een versleten naald
- Weet op tijd wanneer Uw naald vervangen dient te worden
- Haal het maximale uit de aanschaf van Uw element, vooral de duurdere High End elementen
- Houd Uw luistertijd bij en zie de teller oplopen terwijl U geniet van Uw favoriete muziek



FEITEN & FEATURES

De naald (stylus) van Uw element (cartridge) dient na 1000 uur afspeeltijd (soms nog eerder) vervangen te worden. Een versleten naald vermindert de geluidskwaliteit en kan schade toebrengen aan Uw waardevolle platencollectie. Helaas hebben veel vinyl-liefhebbers geen idee hoeveel uren de naald is gebruikt, terwijl er maanden en soms jaren voorbijgaan.

Met de StylusTimer kunt U nauwkeurig Uw afspeeltijd bijhouden. De StylusTimer is een unieke chronograaf, speciaal ontworpen voor platenspelers. Voor slechts € 24,95 is de StylusTimer een must-have gadget voor elke vinyl-liefhebber.

De StylusTimer, voorzien van een roestvrijstalen behuizing, staat mooi bij elke platenspeler. Zonder een StylusTimer is Uw platenspeler incompleet.

*Batterij (AAA-type) niet inbegrepen. Tijdsmeting blijft behouden tijdens de batterijwissel.

disco-antistat

bewährt seit 1978! • proven since 1978!
éprouvée depuis 1978! • iacreditado desde 1978!
sperimentato dall'anno 1978!

made in Germany

DISCO-ANTISTAT
Art. Nr. 1 3000 01



STEREO Test 1/2008: "...ist die unschlagbar günstige und **seit über 30 Jahren** unverändert angebotene Maschine **ein ganz heißer Tipp.**"
STEREO Test 1/2008: "...this machine, which comes for an unbeatable price, unchanged **for more than 30 years, is a very hot tip.**"

Schallplatten-Waschgerät

Reinigt schonend rillentief und verhindert dauerhaft statische Aufladungen. Die optimale Schallplattenpflege für ungestörten Musikgenuss.

Record-cleaning-kit

Each groove is thoroughly cleaned and will remain static free. The best method of record cleaning essential for maximum listening enjoyment.

Lave disque

Nettoie, avec précaution, en profondeur du sillon et évite, à long terme, les charges statiques. L'entretien idéal, permettant de goûter sans troubles les plaisirs de la musique.

Macchina lavadischi

La pulizia è dolce ed evita le cariche elettrostatiche per lungo tempo. E' una pulizia perfetta per godersi la musica senza disturbi.

Aparato limpiador

Limpia profunda y delicadamente los surcos y evita las cargas estáticas de forma duradera. El cuidado ideal para los discos de vinilo que te permitirá disfrutar de la música sin interferencias.

 knosti®

disco-antistat

bewährt seit 1978! • proven since 1978!
éprouvée depuis 1978! • iacreditado desde 1978!
sperimentato dall'anno 1978!

made in Germany

DISCO-ANTISTAT
Art. Nr. 1 3000 01



DISCO-ANTISTAT-MIXTURE
Art. Nr. 1 3010 00

- 1 Waschgehäuse mit eingesetzten Borsten aus Ziegenhaar.
- 2 Label-Dichtschalen mit Aufhängeachse für Singles und LPs.
- 3 Flasche mit 1L Reinigungsflüssigkeit DISCO-ANTISTAT-MIXTURE. Mehrfach verwendbar.
- 4 Trichter, mit dem die Flüssigkeit nach Gebrauch aus dem Waschgehäuse wieder in die Flasche zurückgefüllt wird.
- 5 Abtropfständer mit Auffangschale für 15 LPs oder Singles. Er wird nach Gebrauch in das Gehäuse eingeschoben.

- 1 Record bath with integral brush of soft goats hair.
- 2 Label protector with spindle.
- 3 One litre of DISCO-ANTISTAT-MIXTURE.
- 4 Tunnel with filter papers for reuse of DISCO-ANTISTAT-MIXTURE.
- 5 Drying rack and drip tray for 15 records. Fits into base of bath when not in use.

- 1 Boîtier de la machine à laver les disques, munie d'une fine brosse en poils de chèvre.
- 2 Coquilles plastique avec avec axe, protégeant l'étiquette du disque.
- 3 Flacon avec le mélange DISCO-ANTISTAT-MIXTURE pour le lavage et le traitement.
- 4 Entonnoir pour le remplissage du flaçon après utilisation de la machine à laver les disques.
- 5 Egouttoir pour 15 disques.

- 1 Vasca di lavaggio con spazzole integrate fatte da pelo di capra.
- 2 Doppio disco per proteggere l'etichetta, con asse per i dischi in vinile 33 e 45 giri.
- 3 1 l di liquido speciale DISCO-ANTISTAT-MIXTURE, riusabile.
- 4 Imbuto per riempire il liquido nel flacone dopo l'uso.
- 5 Rastrelliera di appoggio per 15 dischi a 33 o 45 giri. Dopo l'uso viene sistemata nella vasca.

- 1 Carcasa de lavado con cepillos de borra incorporados.
- 2 Cubiertas herméticas para las etiquetas con eje de suspensión para singles y LPs.
- 3 Botella con 1l de líquido limpiador DISCO-ANTISTAT-MIXTURE. Para varios usos.
- 4 Embudo con el que el líquido se puede volver a verter en la botella desde la carcasa de limpieza tras haber sido utilizado.
- 5 Escurridor con bandeja colectora para 15 LPs o singles. Tras utilizarlo se introduce en la carcasa.

BEKAFUN

Heilig hartstraat 23
8870 Izegem (BE)
info@bekafun.be
www.bekafun.be

GENERATION II+

disco-antistat

NEU!

 DISCO-ANTISTAT
 Art. Nr. 1.3500.01

Schallplatten-Waschgerät

Reinigt schonend rillentief und verhindert dauerhaft statische Aufladungen. Die optimale Schallplattenpflege für ungestörten Musikgenuss.



Record-cleaning-kit

Each groove is thoroughly cleaned and will remain static free. The best method of record cleaning essential for maximum listening enjoyment.



Lave disque

Nettoie, avec précaution, en profondeur du sillon et évite, à long terme, les charges statiques. L'entretien idéal, permettant de goûter sans troubles les plaisirs de la musique.



Macchina lavadischi

La pulizia è dolce ed evita le cariche elettrostatiche per lungo tempo. E' una pulizia perfetta per godersi la musica senza disturbi.



Aparato limpiador

Limpia profunda y delicadamente los surcos y evita las cargas estáticas de forma duradera. El cuidado ideal para los discos de vinilo que te permitirá disfrutar de la música sin interferencias.



disco-antistat

NEU!



DISCO-ANTISTAT
Art. Nr. 1.3500.01



GENERATION II+

- + Größere Dichtschalen mit Dichtgummi
- + Füllstandsanzeige
- + Antirutschfüße
- + Achshalterung + Handkurbel



- + Large sealing cups with sealing rubber
- + Grands tampons de fermeture vec caoutchouc d'étanchéité
- + Calotte di tenuta più grandi con guarnizioni in gomma
- + Copas de sellado más grandes con goma de sellado
- + Filling level indicator
- + Indicateur de niveau
- + Indicatore di livello
- + Indicador de nivel
- + Hand crank
- + Manivelle
- + Manovella
- + Manivela
- + Shaft lock
- + Freins d'axe
- + Arresto dell'asse
- + Seguros de los ejes
- + Anti-slip feet
- + Pieds antidérapants
- + Piedini antiscivolo
- + Patas antideslizantes

DISCO-ANTISTAT-MIXTURE
1 L: Art. Nr. 1.3010.00

- 1 Waschgehäuse mit eingesetzten Borsten aus Ziegenhaar.
- 2 Label-Dichtschalen mit Aufhängeachse für Singles und LPs.
- 3 Flasche mit 1L Reinigungsflüssigkeit DISCO-ANTISTAT-MIXTURE. Mehrfach verwendbar.
- 4 Trichter, mit dem die Flüssigkeit nach Gebrauch aus dem Waschgehäuse wieder in die Flasche zurückgefüllt wird.
- 5 Abtropfständer mit Auffangschale für 15 LPs oder Singles. Er wird nach Gebrauch in das Gehäuse eingeschoben.

- 1 Record bath with integral brush of soft goats hair.
- 2 Label protector with spindle.
- 3 1 litre of DISCO-ANTISTAT-MIXTURE. Can be reused multiple times.
- 4 Tunnel with filter papers for reuse of DISCO-ANTISTAT-MIXTURE. Can be reused multiple times.
- 5 Drying rack and drip tray for 15 records. Fits into base of bath when not in use.

- 1 Boîtier de la machine à laver les disques, munie d'une fine brosse en poils de chèvre.
- 2 Coquilles plastique avec avec axe, protégeant l'étiquette du disque.
- 3 Flacon avec le mélange DISCO-ANTISTAT-MIXTURE pour le lavage et le traitement. À usage multiple.
- 4 Entonnoir pour le remplissage du flacon après utilisation de la machine à laver les disques.
- 5 Egouttoir pour 15 disques.

- 1 Vasca di lavaggio con spazzole integrate fatte da pelo di capra.
- 2 Doppio disco per proteggere l'etichetta, con asse per i dischi in vinile 33 e 45 giri.
- 3 1 l di liquido speciale DISCO-ANTISTAT-MIXTURE, riutilizzabile.
- 4 Imbuto per riempire il liquido nel flacone dopo l'uso.
- 5 Rastrelliera di appoggio per 15 dischi a 33 o 45 giri. Dopo l'uso viene sistemata nella vasca.

- 1 Carcasa de lavado con cepillos de borra incorporados.
- 2 Cubiertas herméticas para las etiquetas con eje de suspensión para singles y LPs.
- 3 Botella con 1l de líquido limpiador DISCO-ANTISTAT-MIXTURE. Para varios usos.
- 4 Embudo con el que el líquido se puede volver a verter en la botella desde la carcasa de limpieza tras haber sido utilizado.
- 5 Escurridero con bandeja colectora para 15 LPs o singles. Tras utilizarlo se introduce en la carcasa.

DISCO-ANTISTAT: Art. Nr. 1.3500.01
DISCO-ANTISTAT-MIXTURE: 1 L: Art. Nr. 1.3010.00

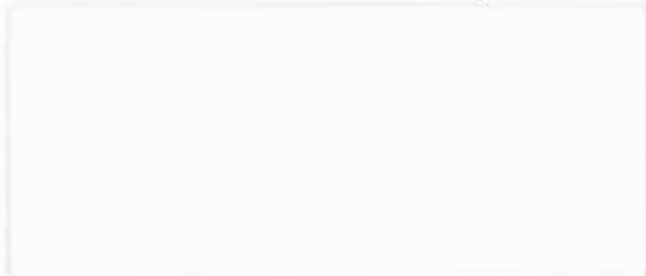

GRADO

Hand-Crafted High End Headphones



“Truly the World’s Finest...”

GRADO

About Grado Labs...

Grado Labs was established by Joseph Grado (1924-2015) in 1953 in Brooklyn. Ever since, Grado has become famous for the remarkable quality and design of their headphones and phonograph cartridges. Joseph Grado has been responsible for more innovations in phono cartridge design than any other person in our lifetime. He has been the inventor of the stereo moving coil phono cartridge and holds more than 48 patents on his name.

In the late 1980s Joseph began the development of what was to become the first true high-end dynamic headphone. The introduction of the Joseph Grado Signature Series of headphones was a major event in the evolution of headphone design. Joseph's painstaking design process, combined with nearly a half century of experience manufacturing precision audio devices, astonished even the most critical reviewers. Joseph extended headphone performance to levels previously attained by only the very best full-range speaker systems in areas of dynamics, pitch control, harmonic accuracy and bass quality. In the process, he once again created a new category - true audiophile quality headphones.



Joseph Grado

In 1990, John Grado, Joseph's nephew, became the President & C.E.O. of Grado Labs. John Grado created and released Grado's first line of headphones that the Brooklyn company is known for today. Till now, he has created over 60 headphones. This Prestige Series of headphones went on to win more awards than any other headphone line in the world.

John has brought Grado's headphone lines from one generation to the next, introducing every headphone that is available to this day. In 2008 he created The i Series, the second generation of Grado. For the first time, he also decided to enter the in-ear headphone market at the urging of his sons, Jonathan and Matthew. In 2011 the in-ears came to fruition. Now, Jonathan Grado became Vice President of Marketing for Grado Labs

Family run since 1953 for three generations, Grado continues to produce the world's finest headphones, all hand-crafted in Brooklyn, New York. Each individual headpnone manufactured by Grado is hand assembled and tested. This meticulous care in design and construction lavished on each Grado headphones contributes to an unchallenged consistency of performance and guarantee of reliability.

For distribution in The Netherlands, Belgium and Luxembourg, Grado headphones are exclusively represented by Tonar International. Since 1954, Tonar has become the specialist for analogue audio, phonograph styli, cartridges and accessories for your turntable and vinyl collection.

tonar
www.tonar.eu

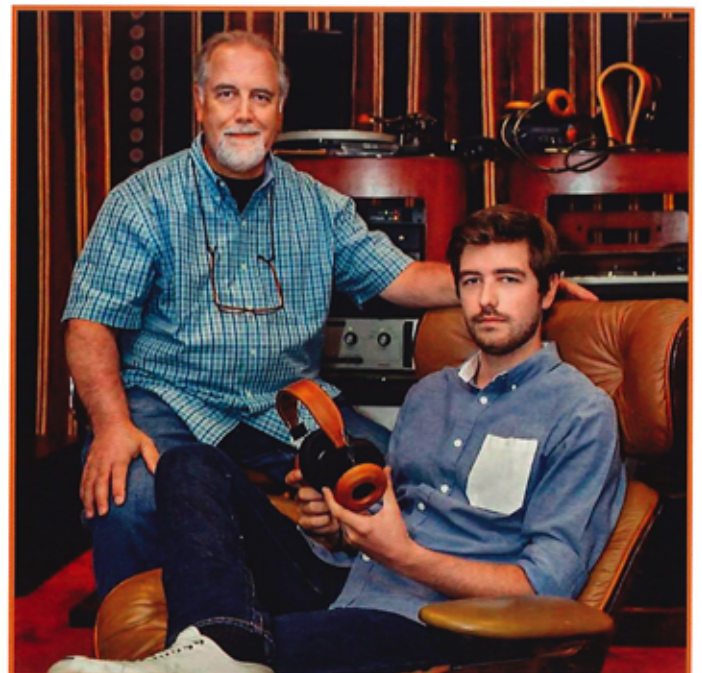

John Grado and his son Jonathan

GRADO

Statement Series



GS2000e

Audio Specs

Transducer Type:	Dynamic
Operating Principle:	Open Air
Frequency Response:	4 - 51,000 Hz
SPL 1mW:	99.8 dB
Nominal Impedance:	32 Ω
Driver Matched dB:	.05 dB

Included Accessories:

Headphones, Warranty, Grado story-sheet, 3.5mm mini adapter, extension cable. A 4-pin XLR balance cable option is available.

Mahogany and Maple, classic tone woods married in audio bliss. The GS2000e combines them in the same manner that luthiers have done for centuries, and for the same reason: resonance. Different types of wood sing with their own personalities while non-fatiguing. All with stunning separation and layering of the music.

The hand-crafted mahogany and maple merged enclosures are a realization of the knowledge from the experience that only Grado Labs knows from working with wood. This technique is used by the finest musical instrument manufacturers from the past and the present. The use of Maple gives the energy of the sound of music to be fully transmitted, then the Mahogany allows it to open up and reveal the true harmonic structure as well as the space that the artist intended.

In addition every component in the GS2000e is considered carefully, the new purpose built 50 mm drivers, the 12 conductor ultra high purity copper cable and ear cushions, all work together for an engaging musical experience. This organic approach embodies what is truly artisanal and is the essence of how we can effectively connect to the music.

GS1000e

Audio Specs

Transducer Type:	Dynamic
Operating Principle:	Open Air
Frequency Response:	8 - 35,000 Hz
SPL 1mW:	99.8 dB
Nominal Impedance:	32 Ω
Driver Matched dB:	.05 dB

Included Accessories:

Headphones, Warranty, Grado story-sheet, 3.5mm mini adapter, extension cable.



Flagship of the handcrafted, carved mahogany series of headphones, the GS1000e 'Statement' is capable of delivering truly stunning sonic performances.

The large chambers fit around your ears, not on top of them, creating a private listening booth. Air flows with the music to keep you comfortable while marveling at the clarity and range. Our select Mahogany tone-woods are hand matched for aesthetic beauty, just as our phenomenal drivers are individually matched for sonic consistency.

The hand-crafted mahogany earpieces utilize an intricate curing process that optimizes the tonal quality while giving them a new look. The GS1000e uses 50mm dynamic transducers and the new 12 conductor cable design. The wood, driver, and cable designs, result in tight control and stability of the upper and lower range of the frequency spectrum to support the GS1000e's world renowned midrange. Grado's GS1000e cushion design actually creates a 'room' for the ears to sit, with a larger soundstage and greater spatial experience for the listener. It was most important to design the correct balance between the driver and our wooden driver housing to give us the pure sound we crave. We believe the GS1000e are one of the most comfortable headphones on the market today. The GS1000e retains a sound that is pure Grado, with warm harmonic colors, rich full bodied vocals, excellent dynamics, and an ultra-smooth top end. The presentation is very detailed, the bass is deep, and the music is very tight while non-fatiguing. All with stunning separation and layering of the music.



GRADO

Professional Series

PS2000e

Audio Specs

Transducer Type:	Dynamic
Operating Principle:	Open Air
Frequency Response:	5 - 50,000 Hz
SPL 1mW:	99.8 dB
Nominal Impedance:	32 Ω
Driver Matched dB:	.05 dB

Included Accessories:

Headphones, Warranty, Grado story-sheet, 3.5mm mini adapter, extension cable. A 4-pin XLR balance cable option is available.



Grado Labs is proud to introduce our new flagship headphone, the PS2000e. This is simply the best headphone we have ever produced and, perhaps, the best in the world. Three generations of the Grado family contributed to its development, which took almost 2 years. Speaking from more than six decades of audio experience... we got it right.

The hand-carved maple inner chamber is clad with our new Smoked Chrome finish for an elegant look. A wider leather head-strap with added padding make for a more comfortable experience. Both are exclusive to the PS2000e.

The unexcelled sonic signature of Maple, first used in our limited edition GH1, deliver a unique desired response. Cladding the wood with metal alloy eliminates ringing and other unwanted distortions. The PS2000e uses a new driver design that also minimizes signal colorations for un-observed detail in your music.

To build our finest headphone yet, you can trust that we used all the best stuff. From the speaker chassis, to the wire, voice coil and magnets, we researched and selected materials of the highest grade. Our diaphragm geometry was redesigned to more accurately convey the signal into music. Developing the new front cap and grill for the new driver resulted in minimized diffractions of the signal emitting from the diaphragm. All this is mounted in a proprietary hybrid housing which gives the driver the utmost support and eliminates distortion and resonance, allowing only the actual signal to come through.

Close your eyes and hear the music like never before, as only a dynamic driver can produce. The PS2000e 'sound stage' is immense and you will enjoy the space and placement of each individual musician. If the artist performed it, and the engineer captured it on the recording, you will hear it.

The PS2000e retains the world famous Grado signature sound, and takes it to a new level of refinement. Be transported. Be Grado.



GRADO



PS1000e

Audio Specs

Transducer Type:	Dynamic
Operating Principle:	Open Air
Frequency Response:	5 - 50,000 Hz
SPL 1mW:	99.8 dB
Nominal Impedance:	32 Ω
Driver Matched dB:	.05 dB

Included Accessories:

Headphones, Warranty, Grado story-sheet, 3.5mm mini adapter, extension cable.

By using tone-wood clad with metal alloy we've obliterated two of the most vexing issues in headphone design: ringing in the chamber, and transient distortion. This gives audio professionals the security of consistent response throughout the frequency range. Did we mention they look awesome?

This hybrid design has an inner sleeve of hand-crafted mahogany made by using the new series 'e' curing process. Its outer housing, machined from aluminum then chrome-plated, utilizes a special processing and casting method to increase the porosity of the alloy. This combination of wood and metal insures that the earphone chamber has no 'ringing' which might obscure detail or add coloration. The way the wood and metal housing moves air and reacts to sound vibrations is virtually unaffected by transient distortions. Grado has also designed the cable for the PS1000e; the twelve-conductor cable design uses UHPLC (Ultra-High Purity, Long Crystal) copper, improves control and stability of the total range of the frequency spectrum. The PS1000e also has a new 50mm driver and a newly re-configured voice coil and diaphragm design, resulting in unsurpassed speed and accuracy responses.

The cushion design creates the correct balance between the driver and housing to support the desired musicality. The cushion design also makes the PS1000e one of the most comfortable headphones in the world. Grado has taken all of our knowledge and over 60 years of experience in controlling resonances and eliminating distortions, and put them into one of our finest headphones ever, the PS1000e. The family is unbelievably proud of this Grado product... listen and enjoy.

PS500e

Audio Specs

Transducer Type:	Dynamic
Operating Principle:	Open Air
Frequency Response:	14 - 29,000 Hz
SPL 1mW:	99.8 dB
Nominal Impedance:	32 Ω
Driver Matched dB:	.05 dB

Included Accessories:

Headphones, Warranty, Grado story-sheet, 3.5mm mini adapter, extension cable.



Most people like music, but Grado PS500e headphones are too good for most people. We make them for music connoisseurs. For the ones who anticipate Amy Winehouse's breath between lyrics. For the ones who absolutely need to place the second violin with their eyes closed. If you get chills from a Cuban trombone solo, we need to talk.

The PS500e is the younger brother to the PS1000e, with newly redesigned 44mm speaker and the improved 8 conductor cable design and a smaller metal and wood hybrid air chamber. Both the hidden mahogany core and powder-coated aluminum housing parts under-go damping treatments that help control and dissipate resonances, for an undistorted flow of the musical signal. The PS500e boasts an overall sound that is pure Grado, with warm harmonic colors, rich full bodied vocals, excellent dynamics, and an ultra-smooth top end. The PS500e is a compact monitoring tool that will put a smile on the face of the most demanding music professionals, as well as the most demanding audiophiles.



Limited Edition

GRADO

Heritage Series

GH2

Audio Specs

Transducer Type:	Dynamic
Operating Principle:	Open Air
Frequency Response:	14 - 28,000 Hz
SPL 1mW:	99.8 dB
Nominal Impedance:	32 Ω
Driver Matched dB:	.05 dB
Vented diaphragm	
Cocobolo air chamber	
UHPLC copper voice coil	
HPIC copper connecting cable	

Included Accessories:

Warranty, Grado story-sheet, 6.5mm Golden Adapter.



We are proud to introduce the second limited edition of our Heritage Series, the cocobolo GH2. Cocobolo, known for fine instruments, furniture, and those chess sets that look too nice to touch, is some of the most beautiful and tonally pleasing woods we have ever used. We're excited that the first Grado to be built from the cocobolo tree is our Heritage Series GH2.

With our first Heritage Series pair, we wanted to pay homage to our Brooklyn roots. We built our GH1 out of maple wood from a fallen tree just a few blocks from where Grado is. It was the first headphone ever built from a Brooklyn tree. While our first headphone in this series focused on our hometown, we wanted to venture further out for the GH2. Cocobolo wood originates from the rain forests of Central America, and its denseness is a primary reason why it produces such a unique sound.

Our limited editions let us experiment with different woods and designs, giving us the opportunity to create a one of a kind Grado. As always, with every wood we use, we wouldn't proceed if we didn't feel its tonal ability was representative of the Grado signature sound. We're extremely pleased to offer the cocobolo GH2 as one of the finest headphones we've ever built at Grado.



GRADO

Reference Series



RS1e

Audio Specs

Transducer Type:	Dynamic
Operating Principle:	Open Air
Frequency Response:	12 - 30,000 Hz
SPL 1mW:	99.8 dB
Nominal Impedance:	32 Ω
Driver Matched dB:	.05 dB

Included Accessories:

Headphones, Warranty, Grado story-sheet, 6.5mm Golden Adapter, extension cable.

Ever wondered what hardcore audiophiles are hearing, and that you might be missing? The Grado RS1e is the point of no return so be warned, cross this threshold and you'll never enjoy mass-market headphones again. Once you've experienced this elegant audio masterpiece you'll grasp the reference.

The new RS1e from Grado uses a different species of handcrafted mahogany from our previous models. The earpieces utilize an intricate curing process that optimizes the tonal quality while giving them a new look. The RS1e places a 50mm dynamic transducer and an 8 conductor cable design in an open-air configuration. The result is a smooth, controlled, and coherent sound with detailed dynamics. Frequency response ranges from 12-30 kHz and the drivers are matched to 0.05dB. Weighing 9oz, the headphones are an example of the wonders of Mother Nature with a gorgeous light mahogany look. The RS1e is a masterpiece in the Grado collection.

RS2e

Audio Specs

Transducer Type:	Dynamic
Operating Principle:	Open Air
Frequency Response:	14 - 28,000 Hz
SPL 1mW:	99.8 dB
Nominal Impedance:	32 Ω
Driver Matched dB:	.05 dB

Included Accessories:

Headphones, Warranty, Grado story-sheet, 6.5mm Golden Adapter.



Leave your candy-colored cans in the toy chest and try a pair of proper headphones. Grado RS2e are hand-crafted from select Mahogany tone-woods, like a fine musical instrument. Our exclusive Series E curing process enhances the natural properties of the wood to produce rich, full-bodied vocals in a light-weight form factor. Put on Brian Eno's 'Another Green World', close your eyes and dream as if you'll live forever.

The RS2e is the little brother of the RS1e but is just as aesthetically pleasing, now utilizing our proprietary curing process that gives a new, lighter look. The RS2e has a 44mm driver and uses The e Series 8 conductor cable design. The hand-crafted mahogany utilizes new advanced damping treatments that help control and dissipate resonances. The RS2e still maintains an overall sound that is pure Grado, with warm harmonic colors, rich full-bodied vocals, excellent dynamics, and an ultra-smooth top end. These truly are an audiophile's dream.



GRADO

Prestige Series

SR60e

Audio Specs

Transducer Type:	Dynamic
Operating Principle:	Open Air
Frequency Response:	20 - 20,000 Hz
SPL 1mW:	99.8 dB
Nominal Impedance:	32 Ω
Driver Matched dB:	.1 dB

Included Accessories:

Headphones, Warranty, Grado story-sheet, 6.5mm Golden Adapter.



Everyone loves a thumping bass and kick-drum, but not at the expense of everything else. The Grado SR60e is your entry to the world of full spectrum audio. You'll actually hear notes you never knew were there. Perhaps your audiophile friends have fueled a desire for the legendary Grado sound but you thought it was out of reach. Try a pair of our affordable open-back headphones and experience fuller, more realistic sound. Club-footed imports can't match the sonic enlightenment from Brooklyn, USA.

Grado has taken one of the world's most legendary headphones and made it even better. The SR60e has a new driver design, a new polymer to better damp resonant distortion in the plastic housing, and a new cable from plug to driver connection. The way the SR60e's new driver and plastic housing move air and react to sound vibrations virtually eliminate transient distortions. This allows the signal flow over the new cable to reproduce sound that has tight control of the upper and lower range of the frequency spectrum, while supporting Grado's world renowned midrange. The SR60e will produce a sound that is pure Grado, with warm harmonic colors, rich full bodied vocals, excellent dynamics, and an ultra-smooth top end.

eGrado

Audio Specs

Transducer Type:	Dynamic
Operating Principle:	Open Air
Frequency Response:	20 - 20,000 Hz
SPL 1mW:	101 dB
Nominal Impedance:	32 Ω
Driver Matched dB:	.1 dB

Included Accessories:

Headphones, Warranty, Grado story-sheet.



Our fabulous eGrado headphones make a great companion on trips, from the air to the underground. Affordable, lightweight and sound great. Wish you could take your favorite brand of headphones on your next flight? A major airline had the same idea and is using eGrado on selected flights to the great delight of passengers.

Designed for the portable electronics market, our goal was to create a street-style headphone that will sonically outperform anything available in the affordable portable market. The eGrado is functionally stylish, lightweight and comfortable. By incorporating the same drivers used in our highly regarded SR60 headphones, we can proudly state that we are indeed the high end choice in the portable market. The eGrado features a behind the neck headband that is comfortable and stylish. We have indeed kept the highly praised Grado sound at a price point that is within reach of all.

GRADO

In-Ear Series



GR8e

Audio Specs

Driver:	Moving Armature
Connector:	3.5mm stereo mini-plug
Frequency Response:	20 -20,000 Hz
Sensitivity:	118dB/1mW
Nominal Impedance:	32 Ω
Max Input Power:	20mW
Cable:	51"/130cm
Weight:	9 grams

Included Accessories:

3 pair ear tips (S M L) proprietary blend of two silicons
 Ear wax proof cloth x4
 Ear wax proof cloth ring x2

A proprietary wide bandwidth moving armature design provides the listener with unsurpassed performance. Small size allows earphone to nestle well within the ear canal, maintaining an excellent air seal for improved bass and reduction of outside noise without causing discomfort.

GR10e

Audio Specs

Driver:	Moving Armature
Connector:	3.5mm stereo mini-plug
Frequency Response:	20 -20,000 Hz
Sensitivity:	113dB/1mW
Nominal Impedance:	32 ohms
Max Input Power:	20mW
Cable:	51"/130cm
Weight:	9 grams

Included Accessories:

3 pair ear tips (S M L) proprietary blend of two silicons
 Ear wax proof cloth x4
 Ear wax proof cloth ring x2

Learning never ends and the GR10e is a result of a constant desire to look at designs and materials and improve upon them. A higher level of precision and new materials allows for the performance of the GR10e to add frequency extension in both the high and low ranges as well as reducing distortion.

iGe

Audio Specs

Driver:	Dynamic
Connector:	3.5mm stereo mini-plug
Frequency Response:	20 -20,000 Hz
Sensitivity:	105dB/1mW
Nominal Impedance:	24 ohms
Max Input Power:	30mW
Cable:	51"/130cm
Weight:	9 grams

Included Accessories:

Four sets of ear tips.

The Grado iGe is the latest in our line of high performance In-Ear headphones. With improved driver response, the proprietary wide bandwidth design provides the listener with an unequalled performance at this price point. The iGe headphone is also the first of Grado's headphones to include an Apple licensed controller which includes a microphone and offers the capability to control volume, music tracks, phone calls, and Siri. The addition of the controller makes this more than just a great sounding headphone, it's now a communication tool to help you navigate the busy world we live in today.

When Grado sets out to design a new product, the most important goal is to be faithful to the music. To also be able to improve the listeners overall experience with the controller is just icing on the cake.

GRADO

Hand-Crafted High End Phonograph Cartridges



“Truly the World’s Finest...”

GRADO

About Grado Labs...

Grado Labs was established by Joseph Grado (1924-2015) in 1953 in Brooklyn. Ever since, Grado has become famous for the remarkable quality and design of their phonograph cartridges. Joseph Grado has been responsible for more innovations in phono cartridge design than any other person in our lifetime. He has been the inventor of the stereo moving coil phono cartridge and holds more than 48 patents on his name.

Born in New York, Joseph Grado left vocational high school at the age of 16, where he had been studying watch-making and had been at the top of his class. He went to work for Tiffany & Company and also taught the craft of watch-making in the evenings. When he discovered hi-fi sound in the early fifties, he visited Saul Marantz to get help in improving the sound of his audio system. Impressed by Joseph's gifted ear, Marantz sent him over to Sherman Fairchild's floundering hi-fi division. With Saul Marantz making the introductions, Joseph promptly landed a top position in the company. As soon as he came up with a design for a viable product, he went out on his own. Scraping together \$2,000, Joseph began to produce phono cartridges. In 1953 he started production of his cartridges on the kitchen table, Grado Labs' first home. In 1955 Joseph opened a factory in Brooklyn on the site of his Sicilian born father's grocery business which, to this day, has been the home of Grado Laboratories.



Joseph Grado

In the early years Grado also produced speakers, turntables and the highly acclaimed wooden tone-arm, which came in several models. In 1963 all of Grado's resources were dedicated to creating the world's finest phono cartridges. In 1976 phono cartridge design was taken to the next level and the first true high-end cartridges were created under the tutelage of Joseph Grado Signature Products.

In 1990, John Grado, Joseph's nephew, became the President & C.E.O. of Grado Labs. He redesigned the entire Grado line of phono cartridges and introduced the wooden Grado housing. Grado's system of damping has virtually eliminated resonant distortions in the magnetic and electrical circuits in the cartridge, bringing analog to a new level of performance. The wooden Reference and Statement Series of phono cartridges have been honored with a Golden Note Award for analog design. Grado also revised the entry level cartridges with the Prestige Series which has been touted as the "Best Value" in phono cartridges in the world.

Family run since 1953 for three generations, Grado continues to produce the world's finest phono cartridges, all hand-crafted in Brooklyn, New York. Each individual cartridge manufactured by Grado is hand assembled and tested for frequency response, channel output, channel balance, phase linearity, inductance and resistance. This meticulous care in design and construction lavished on each Grado cartridge contributes to an unchallenged consistency of performance and guarantee of reliability.

For distribution in The Netherlands, Belgium, Luxembourg, the United Kingdom and Ireland, Grado cartridges are exclusively represented by Tonar International. Since 1954, Tonar has become the specialist for phonograph styli, cartridges and accessories for your turntable and vinyl collection.

tonar

www.tonar.eu

GRADO

IMI

GRADO

Lineage Series

GRADO LINEAGE SERIES



In 1953, Joseph Grado and his family started building cartridges on their kitchen table. Every experience gained in the development of cartridges since the early days has led to the creation of the Lineage Series, consisting of the Epoch and Aeon cartridges. The Epoch and Aeon represent the craftsmanship and unwavering dedication to sound that has been Grado's main focus for over half a century.

The Grado Epoch, is the flagship cartridge of the Lineage Series. For the first time in the history of Grado, sapphire, gold, diamond, and cocobolo wood join forces to produce the finest hand-built

cartridge ever.

The Epoch and Aeon are two cartridges that offer exceptional reproduction of vocals and instruments, with superlative tonal balance, dynamics, imaging, and realism. Grado's coil winding techniques, which have been honed throughout the decades, have let them achieve exact unison between the four coils in each phono cartridge. This allows for a precise balance between channels and accurate stereo imaging. Each Grado is wound with the finest properly sized and annealed 24-karat solid gold wire, which is the ultimate conductor for the transmission of the music from your record.

All of the internal magnetic circuit parts are Swiss screw machined or molded metal, which have tolerances on the order of the best Swiss-made watches. The specially designed diamond stylus, for the first time in a Grado, is mounted on a sapphire cantilever that connects to the stylus generating system. The Epoch and Aeon feature a unique system that has the lowest effective moving mass of any cartridge, while Grado's patented Flux-Bridger generator design creates a superior balance throughout the full frequency spectrum with superb resolution and clarity, which produces an overall truer picture of the music. This is all nestled inside a cocobolo wooden housing.

GRADO EPOCH

Output = 1mV @ 5 CMV

Controlled frequency response = 6 Hz - 72,000 Hz

Channel separation: avg. 47dB - 6 Hz - 72,000 Hz

Loading: 47,000 Ω

Inductance: 30 mH

Resistance: 91 Ω

Non-sensitive to capacitive load

Chassis mass: 12 grams

Tracking force: 1.5 - 1.9 grams



GRADO

Prestige Series

GRADO PRESTIGE SERIES

The Prestige 2 Series is Grado's updated entry level line of cartridges, offering high performance phono cartridges at affordable prices. The cartridges make use of Grado's optimized transmission line (OTL) technology. OTL provides an ideal transfer of signal from the surface of the LP to the generator of the system. This technology rejects unwanted resonances and lowers distortion preserving the fundamental and harmonic frequencies of the music. This also helps keep noise generated by the motor system in the cartridge to a minimum. Grado's OTL stylus/cantilever design makes records sound quieter, improves the height, width, and depth of the soundstage, and present more detail than previously obtainable. All Prestige models available in both ½ inch mount and T4P-mount. All styli in the Prestige series are user replaceable.

The Prestige cartridges are hand assembled by the Grado team in Brooklyn, with some builders having over 25 years of experience. With the recent development of the highly received Lineage Series of cartridges, new technologies have been applied to the Prestige line as well. This updated series of cartridges offers excellent tonal balance, dynamics, and realism, for a most rewarding reproduction of vocals and instruments. The unique coil winding techniques, using ultra high purity copper wire which were honed during the development of the Lineage Series, have let the electrical circuits achieve unison between the four coils in each phono cartridge. This allows for a precise balance between channels and accurate stereo imaging.

The Prestige cartridges are powered by a twin magnet system that optimizes the balance between stereo channels. All internal magnetic circuit parts are held to extremely high tolerances creating the desired stereo imaging. Grado's patented Flux-Bridger design allows the Prestige cartridges to have one of the lowest effective moving mass generating systems while creating an excellent balance throughout the full frequency range.

The development of the Epoch in the Lineage Series brought an in-depth experience with using an outer housing as a damping device. This led to the creation of a process which de-stresses the chassis and dissipates unwanted energy & resonant frequencies, allowing the desired signal to travel freely.

GOLD2



RED2



GREEN2



SILVER2



BLUE2



BLACK2



Frequency Response: 10 - 60,000 Hz
Principal: MI
Channel Separation: 35 (at 1 KHz)
Input Load: 47K
Output: 5mV (5 cm/sec)
Tracking Force: 1.5 gram
Stylus Type: Elliptical
Inductance: 45mH
Resistance: 475
Compliance CUs: 20 mm/N
Stylus Replacement: User replaceable
Mounting: ½ inch/T4P
Weight: 5.5 gram

Frequency Response: 10 - 55,000 Hz
Principal: MI
Channel Separation: 30 (at 1 KHz)
Input Load: 47K
Output: 5mV (5 cm/sec)
Tracking Force: 1.5 gram
Stylus Type: Elliptical
Inductance: 45mH
Resistance: 475
Compliance CUs: 20 mm/N
Stylus Replacement: User replaceable
Mounting: ½ inch/T4P
Weight: 5.5 gram

Frequency Response: 10 - 50,000 Hz
Principal: MI
Channel Separation: 30 (at 1 KHz)
Input Load: 47K
Output: 5mV (5 cm/sec)
Tracking Force: 1.5 gram
Stylus Type: Elliptical
Inductance: 45mH
Resistance: 475
Compliance CUs: 20 mm/N
Stylus Replacement: User replaceable
Mounting: ½ inch/T4P
Weight: 5.5 gram

Both the Silver2 and Gold2 use a four piece OTL cantilever with a Grado specific elliptical diamond stylus mounted on a brass bushing. With the Silver2 and Gold2, a machined turned generator is used to achieve a lower distortion and greater transparency. The Gold2 are hand selected from Silver2 production runs which meet higher test specifications. Approximately 5% of the run usually exhibits these specs and become a Gold2.

Both the Blue2 and Red2 use a four piece OTL cantilever that has a Grado specific diamond stylus mounted on a brass bushing. The Red2 are hand selected from Blue2 production runs which meet higher test specifications. Approximately 10% of the run usually exhibits these specs and become a Red2.

Both the Black2 and Green2 use a three piece OTL cantilever that has a Grado specific diamond stylus mounted on a brass bushing. The Green2 are hand selected from Black2 production runs which meet higher test specifications. Approximately 15% of the run usually exhibits these specs and become a Green2.

GRADO

Prestige Specialty Series

GRADO PRESTIGE SPECIALTY SERIES



SPECIALTY: 78 RPM



The Prestige Specialty Series of 78-RPM cartridges are designed for high output and excellent stability under even severe use. The experts acclaim these cartridges as virtually the finest 78-rpm cartridges in the world. There are two versions available: the Grado 78C and the Grado 78E.

SPECIALTY: MONO PHONO



There are many analog lovers with record collections that include mono albums. Grado strives to have products that will fit all the needs of the analog enthusiast. There are two versions available: the MC+ and the ME+.

SPECIALTY: DJ



Grado's DJ cartridges are the most advanced phono pickups ever offered to the professional DJ market. Built and designed for the demanding needs of the professional DJ musician, Grado cartridges deliver musical performance never known before in the pro DJ market. There are two versions available: the DJ100 and the DJ200.

Frequency Response: 10 - 50,000 Hz
Principal: MI

Input Load: 47K
Output: 5mV (5 cm/sec)
Tracking Force: 2.5 gram
Stylus Type: Conical
Inductance: 45mH
Resistance: 475

Stylus Replacement: User replaceable
Mounting: 1/2 inch/T4P
Weight: 5.5 gram

Each cartridge can be used for either archival or casual play without concern for undue wear on the record. All Grado 78 cartridges have a considerable reduction in tip mass resulting in extended frequency response while tracking forces can range from 2-5 grams. The 78C cartridge uses a three-piece OTL cantilever technology. The 78E cartridge uses a modified four-piece OTL cantilever technology.

Frequency Response: 10 - 50,000 Hz
Principal: MI

Input Load: 47K
Output: 5mV (5 cm/sec)
Tracking Force: 1.5 gram
Stylus Type: Elliptical
Inductance: 45mH
Resistance: 475

Stylus Replacement: User replaceable
Mounting: 1/2 inch/T4P
Weight: 5.5 gram

The MC+ and the ME+ are mounted with an elliptical diamond. The MC+ uses a three-piece OTL cantilever technology. The ME+ uses a modified four-piece OTL cantilever technology. The ME+ uses one of Grado's upgraded generating systems. All wooden body cartridges are available in mono version. This will make your records quieter and enhance the musical pleasure of these recordings.

Frequency Response: 10 - 50,000 Hz
Principal: MI

Channel Separation: 30 (at 1 KHz)
Input Load: 47K
Output: 5mV (5 cm/sec)
Tracking Force: 2.5 gram
Stylus Type: Diamond
Inductance: 45mH
Resistance: 475

Compliance CUs: 30
Stylus Replacement: User replaceable
Mounting: 1/2 inch/T4P
Weight: 5.5 gram

The Prestige model DJ100 uses a three-piece OTL cantilever technology. The Prestige model DJ200 uses a modified four piece OTL cantilever technology. Both cartridges use oxygen free wire in the coils and a specially designed, high polished, diamond mounted in a brass bushing. The Grado specially engineered transmission line cantilever allows for the ideal transfer of music signal and for safe and effective stylus back-cueing.

JICO®

瀬戸彫 *Seto-Hori*

Cellule MC fabriquée à la Main
avec un Corps en Céramique dotée
d'une Pointe de profil Micro-Ridge
et d'un Cantilever en Bore.

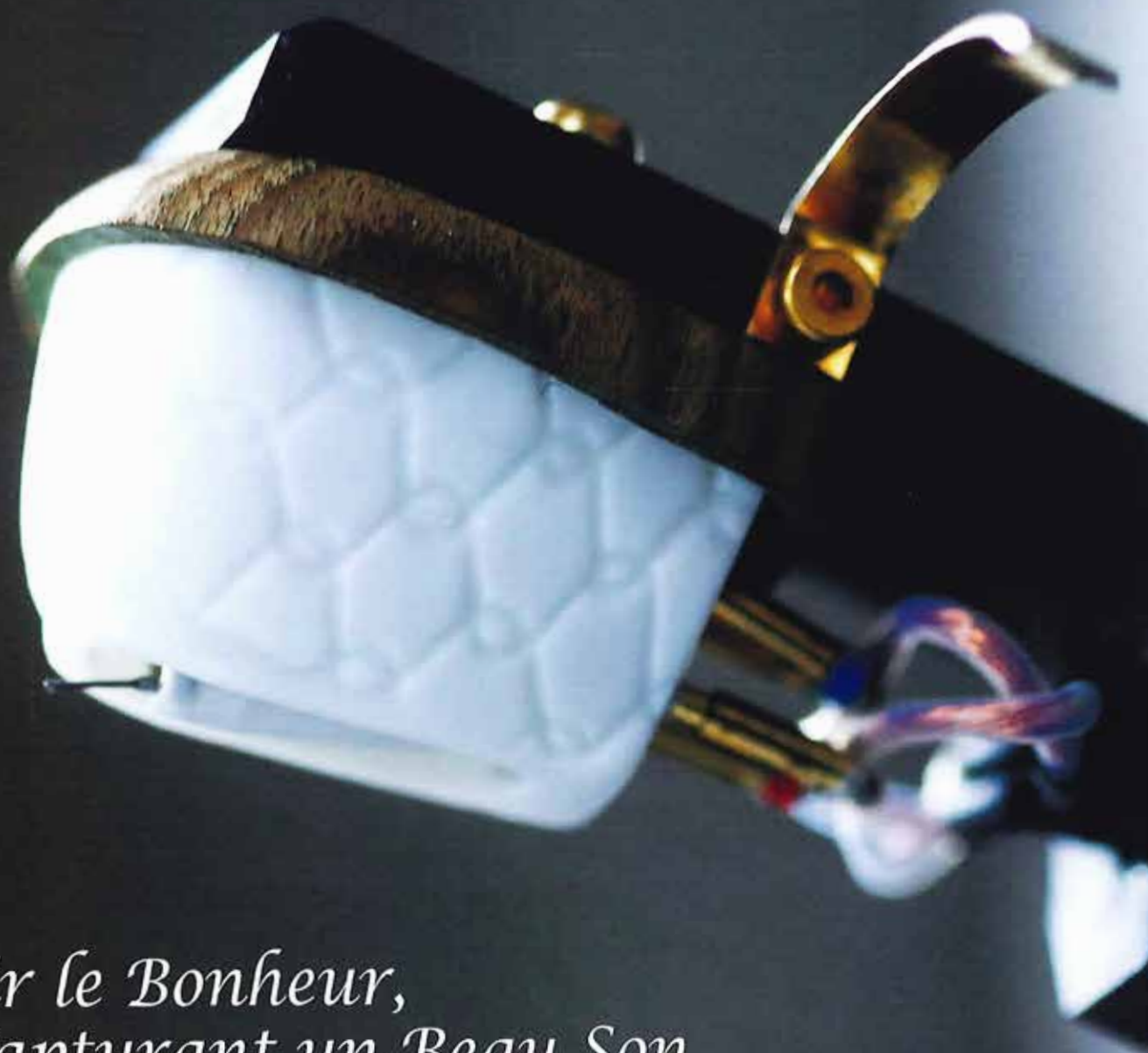

*Saisir le Bonheur,
en Capturant un Beau Son*

JICO®

瀬戸彫 *Seto-Hori*



En tant que fabricant historique de diamants Hi-Fi, établi il y a 140 ans, JICO lance actuellement la cellule "SETO-HORI" à bobine mobile (Moving Coil/MC). La cellule SETO-HORI MC est fabriquée au cœur de la ville de Seto, au Japon. Cette ville est célèbre pour sa poterie et sa céramique. Tant et si bien que le mot générique pour la céramique en japonais est "Setomono".

On a longtemps pensé qu'il était impossible d'utiliser de la céramique pour les cellules. Le moulage ("Kata-Tori") et la cuisson ("Yaki-ire") sont des procédés clés pour les produits céramiques. Cependant, pendant le processus de cuisson, la céramique rétrécit considérablement en taille, et pour cette raison il a été dit que la céramique n'est pas appropriée pour la cabine de cellules. Pendant deux ans, les experts en diamants Hi-Fi de JICO ont travaillé en collaboration avec un laboratoire à Seto et ont étudié le retrait avec une poterie. Le résultat est la cellule SETO-HORI MC avec un corps céramique magnifiquement conçu, un son splendide et une philosophie authentiquement japonaise.

Le dessin unique de la cellule SETO-HORI ressemble aux filets de pêche des pêcheurs japonais. Il suit la philosophie de 'saisir le bonheur en capturant de beaux sons'. Le motif détaillé imitant les filets de pêche n'est pas peint au pinceau, mais dessiné par le moule par une technique appelée "Hori-Tsuke".

La cabine céramique Setomono supprime les vibrations excessives de la cellule haute tension de sortie MC. La cellule SETO-HORI utilise une pointe spéciale de profil micro-ridge, qui a une forme polyédrique. Comme il s'agit d'un diamant Hi-Fi traditionnel, sa durée de vie est au moins trois fois plus longue que celle d'un diamant de forme conique ou elliptique.

Le cantilever en Bore possède une faible masse mais une grande rigidité. Ces caractéristiques permettent à la pointe de tracer plus précisément le sillon et de reproduire les fréquences basses, moyennes et hautes avec une véritable fidélité.

Le corps de la cellule est monté sur un socle en noyer naturel et est traité près de Hamamatsu, la ville célèbre pour ses usines d'instruments de musique de classe mondiale. La combinaison de la céramique japonaise traditionnelle et du bois naturel donne un charme supplémentaire au son.

La cellule SETO-HORI MC est exclusivement fabriquée à la main au Japon.



Moulage du SETO-HORI



Pêcheurs japonais

Specifications:

Tension de sortie:	2mV
Equilibre des canaux en sortie:	<1,5dB/1kHz
Force d'Appui:	2.0 g
Séparation des canaux:	25dB/1kHz
Réponse en fréquence:	15-32 000 Hz
Impédance de sortie:	130Ω/1kHz
Cantilever:	Bore
Fixation du diamant Hi-Fi:	Micro Ridge
Poids net du produit:	11 g
Étui de protection:	Céramique de Seto et bois de noyer

Toutes les cellules sont transportées avec un contrôle d'expédition et une vérification du son à 100%.



La pointe de profil Micro-Ridge



À propos de JICO

En 1873, JICO a commencé son parcours en fabricant des aiguilles à coudre pour Kimonos. Depuis, l'entreprise a acquis une nouvelle expertise technique et artisanale. En 1964, JICO a fusionné ces compétences pour créer des diamants Hi-Fi qui sont devenus la référence de qualité aujourd'hui. Tous les diamants sont assemblés manuellement et chaque diamant est contrôlé individuellement par des *Takumi* (Artisans Japonais) qui mettent tout leur cœur dans chaque produit qu'ils créent. JICO est motivé et dévoué à la préservation de la culture et du son des disques vinyles.

JICO - NIPPON PRECISION JEWEL INDUSTRY CO. LTD.,
Tsutsul Shirokanedai Bld. 3F, 4-9-23 Shirokanedai, Minato-ku, Tokyo 108-0071 Japan





The UK's number one brand for hand-made
turntable cartridges. Pushing the boundaries of
audio technology since 1906.



Moving Magnet Cartridges



Moving Iron Cartridges



Moving Coil Cartridges



E SERIES

moving magnet cartridges

For more than 100 years, the Goldring philosophy has been to promote the precise replication of the original recording, maintaining the creative nuances, musicality and rhythm that the artist intended for you to hear. With the E Series, this is achieved with the three cartridges in the range that have been designed to capture this musical experience. All E series cartridges use Magnetic Duplex™ technology, which achieves a more accurate stereo reading.

Magnetic Duplex™ Technology

The Goldring E Series cartridges feature a special dual magnet arrangement. Magnetic Duplex Technology™ uses two low mass magnets which interact only with the partnering pickup coil, angled at 45 degrees to match the cutting head arrangement. This enables the cartridges to more accurately trace the record groove because they precisely emulate the geometry of the cutting head, making for better stereo separation and a more accurate, involving and musical soundstage.

Expert Adjustment

The E Series cartridges have been designed to allow micro-adjustments to be made during production using a special adjustment screw. This means the cartridge can be safely installed in a typical turntable because the angle that the stylus makes with the record surface (azimuth) has been pre-set. The result is an optimised channel balance with zero degrees of horizontal tracking adjustment required. This ensures a consistent and reassuring performance for the life of the product.

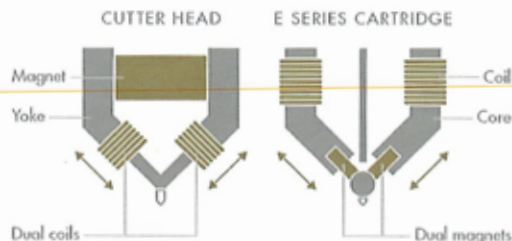

E1



The E1 features a bonded, spherical (0.6 mil) stylus with a round shank. This makes the cartridge "extremely forgiving of set-up adjustment". Also features a carbon reinforced ABS cantilever tube, an effective alternative to more premium aluminium or boron materials.

Cantilever	Carbon
Stylus profile	Spherical
Stylus radius	0.6 mil
Frequency range	20 Hz - 20,000 Hz
Channel balance	1.5 dB at 1 kHz
Channel separation	>20 dB at 1 kHz
Sensitivity	3.5 mV (1 kHz @ 5 cm/sec)
Static compliance	20 mm/N
Tracking angle	208
Load resistance	47 KΩ
Load capacitance	100 - 200 pF
Internal inductance	400 mH
Internal resistance	410Ω
Cartridge mass	6.9 g
Fixing centres	12.7 mm (0.5")
Playing weight	1.5 g - 2.5 g (2.0 g. opt.)

E2



The E2 features the same spherical stylus profile as the E1 but with the additional benefit of an upgraded aluminium cantilever. This is both stiff and light weight allowing the stylus to more accurately trace medium to high frequencies offering more detail and reducing distortion and mis-tracking during loud passages.

Cantilever	Aluminium
Stylus profile	Spherical
Stylus radius	0.6 mil
Frequency range	20 Hz - 20,000 Hz
Channel balance	1.5 dB at 1 kHz
Channel separation	>20 dB at 1 kHz
Sensitivity	3.5 mV (1 kHz @ 5 cm/sec)
Static compliance	20 mm/N
Tracking angle	208
Load resistance	47 KΩ
Load capacitance	100 - 200 pF
Internal inductance	400 mH
Internal resistance	410Ω
Cartridge mass	6.9 g
Fixing centres	12.7 mm (0.5")
Playing weight	1.5 g - 2.5 g (2.0 g. opt.)

E3



The E3 cartridge utilizes an aluminium cantilever as the E2, but benefits from a superior bonded, super-elliptical stylus. This gives it superior high frequency groove detail retrieval ability over ordinary elliptical or spherical styli due to its smaller front to back radius. Its main effect is the reduction of sibilance, especially in high level vocal recordings.

Cantilever	Aluminium
Stylus profile	Elliptical
Stylus radius	0.3 x 0.7 mil
Frequency range	20 Hz - 20,000 Hz
Channel balance	1.5 dB at 1 kHz
Channel separation	>20 dB at 1 kHz
Sensitivity	3.5 mV (1 kHz @ 5 cm/sec)
Static compliance	20 mm/N
Tracking angle	208
Load resistance	47 KΩ
Load capacitance	100 - 200 pF
Internal inductance	400 mH
Internal resistance	410 Ω
Cartridge mass	6.9 g
Fixing centres	12.7 mm (0.5")
Playing weight	1.5 g - 2.5 g (2.0 g. opt.)



G1000 SERIES

moving magnet cartridges

GOLDRING 1006



This hand-built cartridge features a nude elliptical stylus; its shape enables it to more accurately trace the highest frequency record grooves giving it the advantage over ordinary spherical types. The natural diamond shank also gives the stylus a lower tip mass than cheaper metal bonded types lending the cartridge an improved transient response.

Frequency Response	20 Hz -20 kHz ± 3 dB
Channel Balance	within 2 dB @ 1 kHz
Channel Separation	better than 25 dB @ 1 kHz
Sensitivity	6.5 mV ± 1.5 dB, 1 kHz @ 5 cm/sec
Static Compliance	20 mm/N
Dynamic Compliance	@ 10 Hz 10 mm/N
Equivalent tip mass	0.45 mg
Vertical Tracking Angle	24°
Stylus Radius	Elliptical
Stylus Type	Replaceable
Load Resistance	47 k Ω
Load Capacitance	150-200 pF
Internal Inductance	570 mH
Internal Resistance	660 Ω
Cartridge Mass	6.3 g
Cartridge Mass (incl. fixings)	7.6 g
Fixing Centre	12.7 mm (0.5")
Playing Weight	1.5 - 2.0 g (1.7 g nom.)
Replacement Stylus	1006 - D06

GOLDRING 1012GX



The 1012GX uses the acclaimed Gyger II nude diamond stylus. A fine-line elliptical type with a 6 μ m small radius it gives smooth, extended highs, low distortion and reproduces a highly detailed and dynamic sound. Advanced diamond tip polishing ensures excellent tracking ability. Due to its larger major radius, the 1012GX fills the groove completely.

Frequency Response	20 Hz - 20 kHz +/- 3 dB
Channel Balance	within 2 dB @ 1 kHz
Channel Separation	better than 25 dB @ 1 kHz
Sensitivity	6.5 mV +/- 1.5 dB, 1 kHz @ 5 cm/sec
Static Compliance	20 mm/N
Dynamic Compliance	@ 10 Hz 10 mm/N
Equivalent tip mass	0.45 mg
Vertical Tracking Angle	24°
Stylus Radius	Gyger II
Stylus Type	Replaceable
Load Resistance	47 k Ω
Load Capacitance	150 - 200 pF
Internal Inductance	570 mH
Internal Resistance	660 Ω
Cartridge Mass	6.3 g
Cartridge Mass (incl. fixings)	7.6 g
Fixing Centre	12.7 mm (0.5")
Playing Weight	1.5 - 2.0 g (1.7 g nom.)
Replacement Stylus	1012GX - D12GX

GOLDRING 1022GX



The 1022GX cartridge is recommended for the discerning listener as it uses a vital-shank, nude, diamond stylus. This polyhedral, line-contact diamond profile has a very low tip-mass and a large contact area whilst being very narrow from front to back, even enabling the undistorted retrieval of ultrasonic frequencies in a recording.

Frequency Response	20Hz - 20kHz ± 3 dB
Channel Balance	within 2 dB @ 1 kHz
Channel Separation	better than 25 dB @ 1 kHz
Sensitivity	6.5 mV ± 1.5 dB, 1kHz @ 5 cm/sec
Static Compliance	20 mm/N
Dynamic Compliance	@ 10 Hz 10 mm/N
Equivalent tip mass	0.45 mg
Vertical Tracking Angle	24°
Stylus Radius	Vital PH
Stylus Type	Replaceable
Load Resistance	47 k Ω
Load Capacitance	150 - 200 pF
Internal Inductance	570 mH
Internal Resistance	660 Ω
Cartridge Mass	6.3 g
Cartridge Mass (incl. fixings)	7.6 g
Fixing Centre	12.7 mm (0.5")
Playing Weight	1.5 - 2.0 g (1.7g nom.)
Replacement Stylus	1022GX - D22GX

GOLDRING 1042



The 1042 is made for the audiophile who demands the ultimate sonic performance from their system. It uses a nude, natural-diamond stylus with a Gyger S profile. This is a revolutionary line-contact type which is shaped closely resemble the record cutting head than. The 1042 traces the smallest groove detail with complete fidelity.

Frequency Response	20 Hz-20 kHz +/- 3 dB
Channel Balance	within 2 dB @ 1 kHz
Channel Separation	better than 25 dB @ 1 kHz
Sensitivity	6.5 mV +/- 1.5 dB, 1 kHz @ 5 cm/sec
Static Compliance	20 mm/N
Dynamic Compliance	@ 10 Hz 10 mm/N
Equivalent tip mass	0.45 mg
Vertical Tracking Angle	24°
Stylus Profile	Gyger S
Stylus Type	Replaceable
Load Resistance	47 k Ω
Load Capacitance	150-200 pF
Internal Inductance	570 mH
Internal Resistance	660 Ω
Cartridge Mass	6.3 g
Cartridge Mass (incl. fixings)	7.6 g
Fixing Centre	12.7 mm (0.5")
Playing Weight	1.5 - 2.0 g (1.7 g nom.)
Replacement stylus	1042 - D42



G2000 SERIES

moving iron cartridges

All Goldring 2000 series cartridges feature moving iron technology. This lends them the high levels of detail associated with more expensive moving coil designs whilst retaining the convenience of a replaceable stylus and high output associated with moving magnet types. The cartridge employs a fixed samarium cobalt magnet and high output coil combination so that a very light iron/nickel cantilever end-piece can be used instead of the much heavier permanent magnet used in conventional designs. This reduces the moving mass allowing the stylus to trace the record groove more faithfully. Because of their high output, Goldring 2000 series cartridges should be used with the standard moving magnet phono input of an integrated amplifier.

Moving iron technology

The moving iron (MI) cartridge is similar in operation to the moving-magnet type except that a very light, hollow, temporary magnet or armature is used instead of a small permanent magnet. This has the advantage that the moving parts of the generator can be made from light magnetic alloys and therefore have less mass, responding to the groove wall more accurately. The cantilever transfers the mechanical vibrations from the record groove to the hollow armature. The magnetic field induced in it by the large fixed permanent magnet suspended above it induces a changing magnetic "flow" through the pole shoes which, in turn, generates an electromotive force in the fixed coils in proportion to the mechanical vibration.

The coil must be connected to a special phono amplifier input via the turntable leads so that the low voltage generated by the cartridge (typically 5 mV) is boosted to several volts to drive the speakers. All MI cartridges have a relatively high output and require a 47 kΩ load impedance for current to flow making them compatible with the basic MM phono input found as standard on many integrated amplifiers. If your amplifier does not feature a MM phono input, these can be purchased separately at a reasonable cost.

The Goldring 2000 series offers a hierarchy of MI cartridges to complement your chosen performance level. From the entry-level up to the needs of the high end audiophile, but all with the signature Goldring sound.

Moving Magnet cartridge

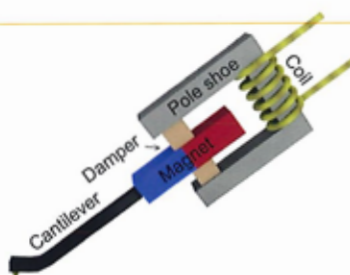

Moving Iron cartridge

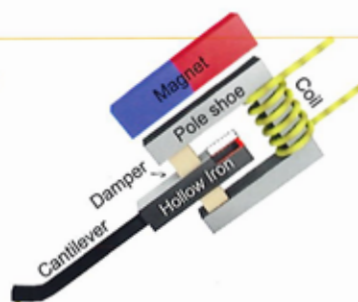

GOLDRING 2100



The 2100 features a bonded elliptical diamond stylus producing high frequency clarity and quality sound. The 2100 can be used to upgrade many budget turntables.

GOLDRING 2200



The 2200 features a bonded elliptical diamond stylus and alumite cantilever which offers higher definition and improved transient response when compared to a conventional cantilever and spherical stylus.

Frequency Response	20 Hz - 20 kHz +/- 3 dB
Channel Balance	within 2 dB @ 1kHz
Channel Separation	better than 20 dB @ 1 kHz
Sensitivity	6.5 mV ±1.5 dB, 1kHz @ 5 cm/sec
Static Compliance	35 mm/N
Dynamic Compliance	@ 10 Hz 16 mm/N
Vertical Tracking Angle	24°
Stylus Radius	Elliptical 0.7 x 0.3 mil
Stylus Type	Replaceable
Cantilever	Aluminium
Load Resistance	47 kΩ
Load Capacitance	100-200 pF
Internal Inductance	550 mH
Internal Resistance	550 Ω
Cartridge Mass	7.4 g
Cartridge Mass (incl. fixings)	8.6 g
Fixing Centre	12.7 mm (0.5")
Playing Weight	1.5 - 2.0 g (1.7 g nom.)

Frequency Response	20 Hz - 20 kHz +/- 3 dB
Channel Balance	within 2 dB @ 1 kHz
Channel Separation	better than 20 dB @ 1 kHz
Sensitivity	6.5 mV ±1.5 dB, 1 kHz @ 5 cm/sec
Static Compliance	35 mm/N
Dynamic Compliance	@ 10 Hz 16 mm/N
Vertical Tracking Angle	24°
Stylus Radius	Bonded Elliptical 0.7 x 0.3 mil
Stylus Type	Replaceable
Cantilever	Alumite
Load Resistance	47 kΩ
Load Capacitance	100-200 pF
Internal Inductance	680 mH
Internal Resistance	550 Ω
Cartridge Weight	7.4 g
Cartridge Mass (incl. fixings)	8.6 g
Fixing Centre	12.7 mm (0.5")
Playing Weight	1.5 - 2.0 g (1.7 g nom.)



G2000 SERIES

moving iron cartridges

GOLDRING 2300



By using an elliptical nude-diamond stylus, the 2300 offers high frequency clarity and excellent transient response due to its lower tip-mass compared to bonded types. This record cartridge will upgrade many mid-range turntables, allowing them to produce an even finer sound.

Frequency Response	20 Hz - 20 kHz +/- 3 dB
Channel Balance	within 2 dB @ 1 kHz
Channel Separation	better than 20 dB @ 1 kHz
Sensitivity	6.5 mV ±1.5 dB, 1 kHz @ 5 cm/sec
Static Compliance	35 mm/N
Dynamic Compliance	@ 10 Hz 16 mm/N
Vertical Tracking Angle	24°
Stylus Radius	Nude Elliptical
Stylus Type	Replaceable
Cantilever	Alumite
Load Resistance	47 kΩ
Load Capacitance	100 - 200 pF
Internal Inductance	680 mH
Internal Resistance	550 Ω
Cartridge Mass	7.4 g
Cartridge Mass (incl. fixings)	8.6 g
Fixing Centre	12.7 mm (0.5")
Playing Weight	1.5 - 2.0 g (1.7 g nom.)

GOLDRING 2400



The 2400 has a low-mass, "Vital" shank, nude diamond stylus and tapered aluminum cantilever for increased resolution. This polyhedral, line-contact profile has a very low tip-mass and a large contact area whilst being very narrow from front to back, enabling the accurate retrieval of even the highest frequencies in the recording.

Frequency Response	20 Hz - 20 kHz +/- 3 dB
Channel Balance	2 dB @ 1 kHz
Channel Separation	>20 dB @ 1 kHz
Sensitivity	6.5 mV +/- 1.5 dB, 1 kHz @ 5 cm/sec
Static Compliance	35 mm/N
Dynamic Compliance	@ 10 Hz 16 mm/N
Vertical Tracking Angle	24°
Stylus Radius	Vital
Stylus Type	Replaceable
Cantilever	Tapered Aluminium
Load Resistance	47 kΩ
Load Capacitance	100 - 200 pF
Internal Inductance	720 mH
Internal Resistance	550 Ω
Cartridge Mass	7.4 g
Cartridge Mass (incl. fixings)	8.6 g
Fixing Centre	12.7 mm (0.5")
Playing Weight	1.5 - 2.0 g (1.7 g nom.)

GOLDRING 2500



The 2500 uses a nude, square shank, natural diamond stylus in a diagonal orientation with a proprietary 2SD line-contact profile. The stylus only contacts the groove wall along the short radius ridges which are so fine that it can accurately trace details down to 4 microns – enough for replay of quadraphonic records.

Frequency Response	20 Hz - 20 kHz +/- 3 dB
Channel Balance	within 2 dB @ 1 kHz
Channel Separation	better than 20 dB @ 1 kHz
Sensitivity	6.5 mV ±1.5 dB, 1 kHz @ 5 cm/sec
Static Compliance	35 mm/N
Dynamic Compliance	@ 10 Hz 16 mm/N
Vertical Tracking Angle	24°
Stylus Radius	2SD
Stylus Type	Replaceable
Cantilever	Tapered Aluminium
Load Resistance	47 kΩ
Load Capacitance	100-200 pF
Internal Inductance	720 mH
Internal Resistance	550 Ω
Cartridge Mass	7.4 g
Cartridge Mass (incl. fixings)	8.6 g
Fixing Centre	12.7 mm (0.5")
Playing Weight	1.5 - 2.0 g (1.7 g nom.)

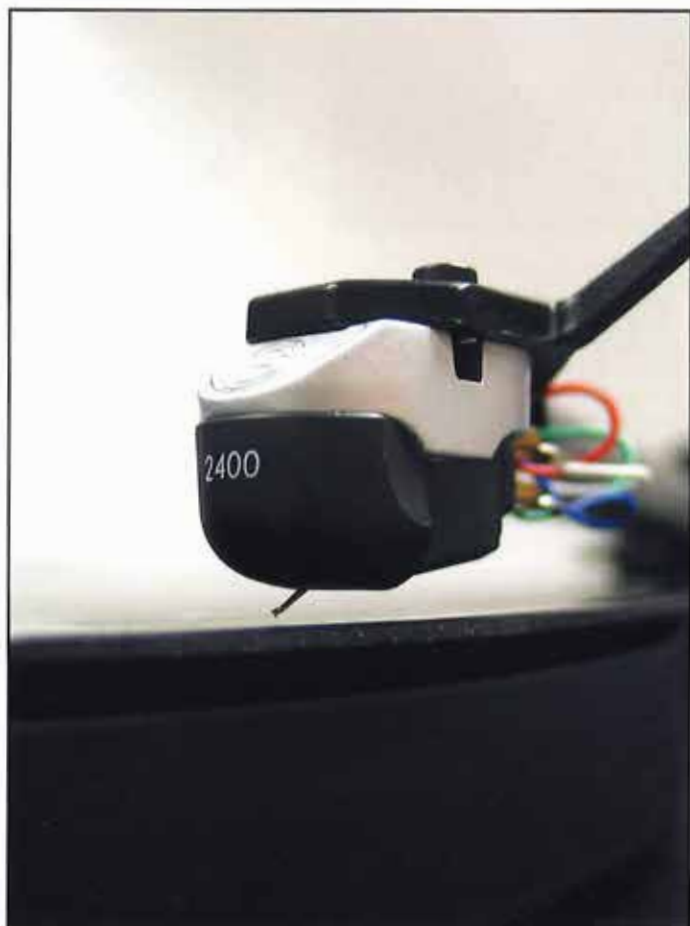



EROICA - ELITE - LEGACY

moving coil cartridges

EROICA H



The Eroica H is a true audiophile moving-coil cartridge designed to be used with any type of phono input. It features the famous Gyger II diamond stylus profile, a nude, fine-line elliptical type with a 6 µm lesser radius, which gives smooth, extended highs, low distortion and reproduces a highly detailed and dynamic sound. The pick-up coils are hand-wound on a pure iron armature and suspended in a magnetic circuit of advanced design, featuring low mass and powerful rare earth magnets.

Frequency Response	20 Hz - 22 kHz ± 3 dB
Channel Balance	within 1 dB @ 1 kHz
Channel Separation	better than 25 dB @ 1 kHz
Sensitivity	2.5 mV ± 1 dB, 1 kHz @ 5 cm/sec
Static Compliance	30 mm/N
Dynamic Compliance	@ 10 Hz 18 mm/N
Equivalent tip mass	0.6 mg
Vertical Tracking Angle	24 °
Stylus Radius	Gyger II
Stylus Type	Non-Replaceable
Load Resistance	47 kΩ
Load Capacitance	100 - 500 pF
Internal Inductance	0.2 mH
Internal Resistance	77 Ω
Cartridge Mass	5.5 g
Cartridge Mass (incl. fixings)	6.6 g
Fixing Centre	12.7 mm (0.5")
Playing Weight	1.5 - 2.0 g (1.7 g nom.)

EROICA LX



The Eroica LX moving-coil cartridge features the famous Gyger II diamond stylus profile. It reproduces a highly detailed and dynamic sound. The pick-up coils are hand-wound on a pure iron armature and suspended in a magnetic circuit of advanced design, featuring low mass and powerful rare earth magnets. The low output Eroica LX offers an exceptionally high standard of performance and reliability and must be used with an amplifier which features a dedicated moving coil phono input.

Frequency Response	20 Hz - 22 kHz ± 2 dB
Channel Balance	within 1 dB @ 1 kHz
Channel Separation	better than 25 dB @ 1 kHz
Sensitivity	0.5 mV ± 1dB, 1kHz @ 5 m/s
Static Compliance	30 mm/N
Dynamic Compliance	@ 10 Hz 18 mm/N
Equivalent tip mass	0.35 mg
Vertical Tracking Angle	24 °
Stylus Radius	Gyger II
Stylus Type	Non-Replaceable
Load Resistance	100 Ω
Load Capacitance	100 - 1000 pF
Internal Inductance	12 µH
Internal Resistance	8 Ω
Cartridge Mass	5.5 g
Cartridge Mass (incl. fixings)	6.6 g
Fixing Centre	12.7 mm (0.5")
Playing Weight	1.5 - 2.0 g (1.7 g nom.)

ELITE



The Elite is an ultra high-performance low-output moving coil cartridge which incorporates all of Goldring's most time-honoured design features. These include advanced magnetic circuitry with neodymium magnet and an ultra-rigid Pocar® body. The Elite incorporates a Gyger S line-contact nude diamond stylus, providing maximum groove information retrieval and an outstandingly smooth and extended frequency response. The Swedish iron armature is hand-wound with pure silver wire.

Frequency Response	20 Hz-30 kHz +/- 2 dB
Channel Balance	within 1 dB @ 1 kHz
Channel Separation	better than 25 dB @ 1 kHz
Sensitivity	0.5 mV +/- 1 dB @ 1 kHz
Static Compliance	30 mm/N
Dynamic Compliance	@ 10 Hz 18 mm/N
Equivalent tip mass	0.35 mg
Vertical Tracking Angle	20 °
Stylus Radius	Gyger S
Stylus Type	Non-Replaceable
Load Resistance	100 Ω
Load Capacitance	100 - 500 pF
Internal Inductance	2 uH
Internal Resistance	8 Ω
Cartridge Mass	5.7 g
Cartridge Mass (incl. fixings)	6.6 g
Fixing Centre	12.7 mm (0.5")
Playing Weight	1.5 - 2.0 g (1.7 g nom.)

LEGACY



The Legacy boasts an ultra low resonance magnesium metal body which is both very light and extremely strong. It has threaded inserts, allowing the cartridge to be easily mounted and aligned into the headshell. The stylus is a 'Vital' fine-line diamond, which is highly polished and gives extremely low distortion. The stylus attached to a hard alloy cantilever which transfers the maximum level of detail from the diamond to the coils; the latter are hand wound using only the highest purity copper.

Frequency Response	20 Hz-20 kHz +/- 3 dB
Channel Balance	within 2 dB @ 1 kHz
Channel Separation	better than 25 dB @ 1 kHz
Sensitivity	6.5 mV +/- 1.5 dB, 1 kHz @ 5 cm/sec
Static Compliance	20 mm/N
Dynamic Compliance	@ 10 Hz 10 mm/N
Equivalent tip mass	0.45 mg
Vertical Tracking Angle	24 °
Stylus Profile	Gyger S
Stylus Type	Replaceable
Load Resistance	47 kΩ
Load Capacitance	150-200 pF
Internal Inductance	570 mH
Internal Resistance	660 Ω
Cartridge Mass	6.3 g
Cartridge Mass (incl. fixings)	7.6 g
Fixing Centre	12.7 mm (0.5")
Playing Weight	1.5 - 2.0 g (1.7 g nom.)



ETHOS

moving coil cartridges

The Goldring Ethos is a top-of-the-range cartridge with outstanding sound reproduction capabilities, designed and hand-built in the United Kingdom. By using a top quality Vital line-contact diamond stylus, the Ethos has an exemplary ability to retrieve every last ounce of detail from the record groove. The high channel separation reproduces an exceptionally accurate and realistic stereo sound stage. At the same time the enhanced trackability and absence of colouration delivers undiluted enjoyment of the music.

Inside the Ethos

At the heart of the Ethos cartridge is Goldring's hand-built GOL-1 moving-coil generator. Developed in the heyday of vinyl, it takes advantage of a lower coil inductance and reduced effective mass when compared to traditional moving magnet types to give a smooth, extended frequency response with enhanced trackability.

For Ethos, we have carefully improved numerous aspects of its design and assembly to further enhance its world class reputation. With modern set-up and test equipment at their disposal, our UK based expert craftsmen are able to precisely build and individually adjust each cartridge so that it is capable of retrieving every last detail from the record groove.

The result is that one becomes simply immersed in the musical experience... And that's our whole Ethos.

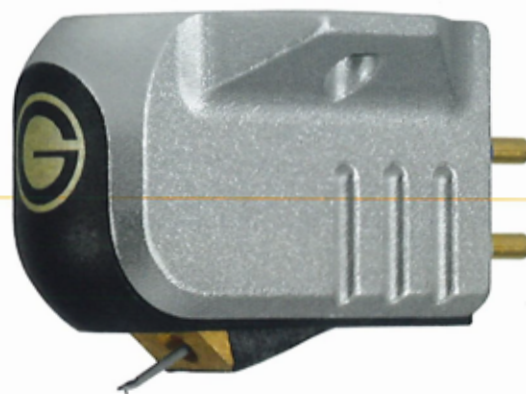

"Ethos: Goldring's most advanced moving coil cartridge, for unparalleled performance"

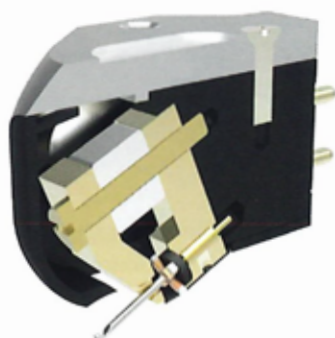

Stylus profile	Vital line-contact
Cantilever	Aluminium alloy
Replacement stylus	Factory replaceable
Frequency range	10 Hz - 32 kHz
Frequency response	± 2 dB (35 Hz - 20 kHz)
Channel balance	<1 dB at 1 kHz
Channel separation	>30 dB at 1 kHz
Sensitivity	0.5 mV ± 1 dB @ 1 kHz, 5 cm/s (rms)
Static compliance	25 mm/N
Dynamic compliance	15 mm/N
Vertical tracking angle	20°
Load resistance	100 Ω
Load capacitance	100 - 1000 pF
Internal inductance	7.5 µH
Internal resistance	4 Ω
Cartridge mass	7.7 g
Total mass (incl. fixings)	8.5 g
Fixing centres	12.7 mm (0.5 in)
Playing weight	1.5 - 2.0 g (1.75 g)



Line-Contact Stylus

The line-contact diamond profile provides a large contact area with the groove wall, improving the retrieval of high frequency detail and reducing groove wear. Its vital-shaped shank has a low tip mass giving the design exceptionally good trackability.

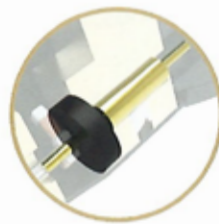

Optimised Suspension

The new damper pad uses a bespoke butyl rubber compound to keep the system critically damped. Combined with an expertly tensioned tie-wire, the cartridge remains ultra-stable even during the loudest and most complex passages.



Alloy Cantilever

The stiff and lightweight alloy cantilever tube has been tuned to the ideal length for cartridge stability and ride height. Its length has been optimised to reduce inertia in the suspension system and improve trackability.



Neodymium Magnet

A very light and powerful neodymium magnet is clamped between two pole shoes creating a perfectly uniform magnetic field gap, within which the cross armature is suspended. This gives Ethos its typically flat and extended frequency response.



Cross-Shaped Armature

The coils are wound around a cross-shaped armature of pure, high-permeability, Swedish iron. The reduced unsprung mass improves the ability for the stylus to track the groove wall and the coil separation minimises cross-talk, improving the stereo image.



Aluminium Body Shell

The body is precision-milled from a low density, rigid, aircraft grade aluminium which helps to maintain a low effective mass and enables it to dissipate unwanted resonances into the tonearm where they are effectively 'grounded'.

NAGAOKA

Nagaoka is unique in the cartridge business having produced styli, cartridges and accessories for records since 1940. Nagaoka has endeavoured manufacturing styli and pick-up cartridges of the best possible quality to satisfy the expectations of true vinyl connoisseurs — bringing the highest musical and creative expression from the concert hall to the comfort of your home.

Through its long track record in the field of phonograph technology, Nagaoka has perfected the stylus manufacturing technologies and continues to develop new innovative solutions to improve a full audio experience. Each Nagaoka phono cartridge is produced with precision craftsmanship, stringent quality control, careful assembly and thorough inspection. Nagaoka is the world's only cartridge producer that manufactures all high precision parts of the cartridge in its own factories: from the diamond tips, the cantilevers and the samarium cobalt magnets, to even the coils.

As we share a passion for analogue sound reproduction, Nagaoka helps to provide you with all essential tools — from hi-fi styli and cartridges to accessories for sound enhancement and record cleaning — so you can enjoy the authentic vinyl sound.



tonar

Nagaoka is exclusively represented in Europe by Tonar International. Both companies share a long history of fruitful cooperation, that goes back to Tonar's foundation in 1954. Ever since, Tonar has become the specialist for phonograph styli, cartridges and accessories for your turntable and vinyl collection.

Nagaoka presents:

The phonograph cartridge is perhaps the most important component of your whole vinyl sound system. The cartridge converts the vibrations of the stylus into audio signals. The quality and shape of the stylus and the tolerances in the manufacturing process are of the utmost importance to ensure that the translation of the information in the grooves is perfect and no sound is lost or noise is added in the process.

The high performance Nagaoka MP (Moving Permalloy) cartridge line incorporates the most state-of-the-art materials. The cartridges of the MP Series provide an equal sound reproduction in all frequency ranges: from the super deep low tones to the crystal clear high notes. The MP-cartridges clearly accentuate and separate every detail — however small — of the musical instruments and voices of the artists.

An oscillation system aimed at perfect tracking capability

Central to the high performance of the Nagaoka MP Series is the development of an oscillation system that perfectly captures the information engraved in the grooves of the record. Originally, in order to transform the vibrations of the stylus into soundwaves, a cartridge makes use of two essential components: a moving magnet and fixed coils. As the stylus tracks the record groove, the modulations of the groove move the stylus back and forth and up and down. The stylus in turn moves the cantilever, which moves the magnet attached to its opposite end, which ultimately creates a current in the fixed coils located in the cartridge body that is sent to the (pre)amplifier.

The way MP cartridges work is slightly different. Instead of a real magnet at the opposite end of the cantilever there is Permalloy material (a nickle-iron alloy). This material is not a magnet itself, but in the field of a powerful magnet it acts as if it were a magnet — we

***Nagaoka is the world's only
cartridge producer that
manufactures all high precision
parts of the cartridge in its own
factories: from the diamond tips,
the cantilevers and the samarium
cobalt magnets, to even the coils.***

Cartridge Series

call it Induced Magnet or IM (also known in some cartridge models as moving Iron). The fixed Samarium Cobalt magnet in the cartridge body activates this magnetic property in the Permalloy and so the coils in the cartridge see a "moving magnet". The big advantage of the MP-cartridges is that the Permalloy material is substantially lighter in weight than a real magnet and so the moving mass of the tip-cantilever-Permalloy combination is considerably lower, making it much easier for the combination to follow the modulations in the groove accurately.

Samarium cobalt magnet

The MP-cartridges are equipped with a fixed samarium cobalt magnet. This magnet has an extremely powerful magnetic field, much stronger than any other type of magnet. The weight of this magnet in comparison to the power is much smaller than other magnets reducing the weight of the cartridge considerably and enabling the magnet to be mounted much closer to the Permalloy tip of the cantilever. By reducing the distance less magnetic energy will be lost, which has a very positive effect on the sound quality.

The stylus tip and the cantilever

Since its founding, Nagaoka has developed a strong track record on precision processing and microfabrication of difficult-to-cut materials such as sapphire and diamond. The MP-series cartridges have a low mass naked diamond tip (except

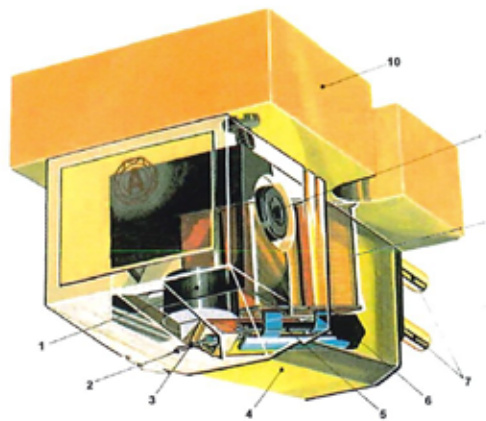

- ① Samarium cobalt magnet
- ② Stylus tip
- ③ Cantilever
- ④ Shield case
- ⑤ Permalloy oscillator
- ⑥ Cylinder
- ⑦ Gold plated terminal pins
- ⑧ Coils
- ⑨ Anti-resonance screw
- ⑩ Housing

for the MP-100 and MP-110 which have a light weight bonded diamond tip), which is only one third of the mass of conventional diamond tips. It is manufactured by super fine particle grinding, based on extended stylus technology.

The cantilever is designed with a unique hollow construction, fabricated with high precision at the micro-world level. Since high rigidity is essential for a cantilever, Nagaoka has selected the most light-weight and strong materials. The MP-500, the MP-300 and the MP-200 have a cantilever made out of Boron, a material that is ultra-light weight, extremely rigid and more durable than granite, beryllium or carbon fibre. The MP-150 has a hardened tapered aluminum cantilever which is more rigid than normal aluminum cantilevers because of its shape. The rigid cantilever of the MP-cartridges ensures an even and distortion free sound reproduction.

Avoiding unnecessary resonance

Every material used for the production of the MP-cartridges has been critically

selected to eliminate unnecessary resonance. The frame of the cartridges is made from high purity aluminum, which is light in weight and has a high physical strength. Because of its even density, sound distortion caused by vibration of the frame body is minimal. In addition, the replaceable stylus and the bodies of the MP-500 and MP-300 have been completely tightened with a special screw. This eliminates the occurrence of resonance of the plastic knob of the replaceable stylus.

Due to Nagaoka's dedication to precision craftsmanship and their continuous pursuit of perfect sound reproduction, the MP-line will not fail to provide you with the best musical satisfaction. With these *Master Piece* cartridges, Nagaoka invites you to enjoy your record collection in excellent audio quality with vivid, colourful and dimensional clarity and detailed sound.

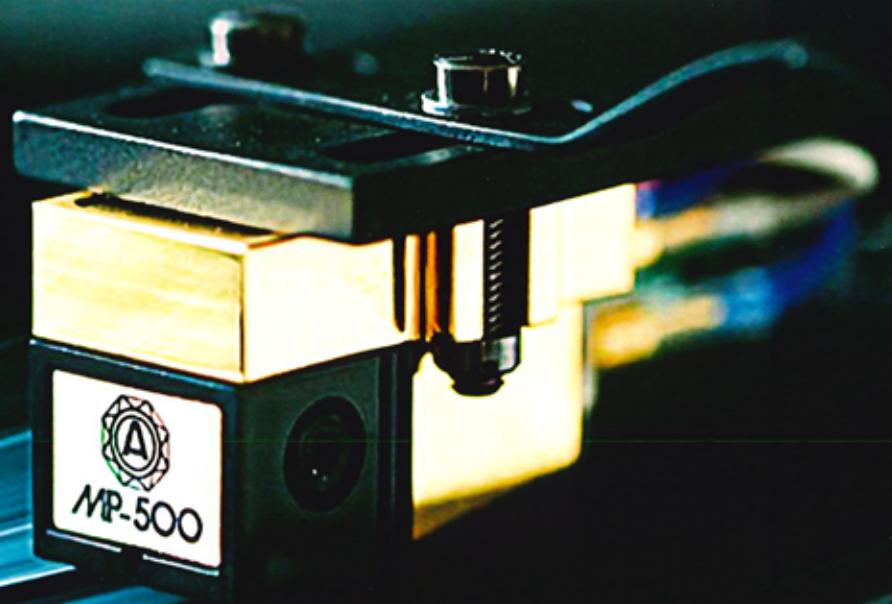

NAGAOKA MP-500

The MP-500 is Nagaoka's top-of-the-line phonograph cartridge. It offers the finest audio experience of the MP-series. The cartridge features an exclusive super-rigid body for ultra low resonance and superlative fidelity with a fine polished line contact diamond stylus. Its characteristics include a powerful samarium cobalt magnet, low-mass high-strength rigid boron cantilever, carbon fiber reinforced plastic shoe and anti-ferro magnetic permalloy shield casing. The MP-500 plays your records with image solidity, detailed resolution, and bass extension.

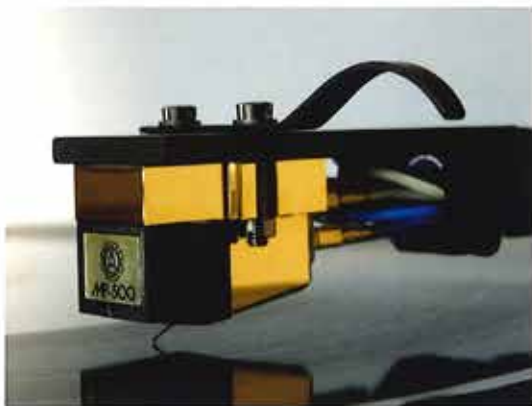

Output Voltage	3,0 mV (5 cm/sec)
Frequency characteristics	20-25.000 Hz
Channel Separation	27 dB (1 KHz)
Channel balance	1.0 dB or less
Load resistance	47 K Ω
Cantilever	Boron
Stylus tip shape/radius	Line contact
Stylus tip material	naked diamond
Stylus pressure	1,3 – 1,8 g
Cartridge weight	8,0 g

- [Tonar article no. 9353](#)
- [Tonar article no. 9401 \(premounted in headshell\)](#)

NAGAOKA MP-300

The Nagaoka MP-300 is an advanced technology cartridge that features a special elliptical diamond mounted on a boron cantilever for superior record groove retrieval. It offers harmonically accurate and excellent rendition of voice and music. As such, the MP-300 stands for sophistication, refinement and high-definition at all audible frequencies to be easy on the ears.

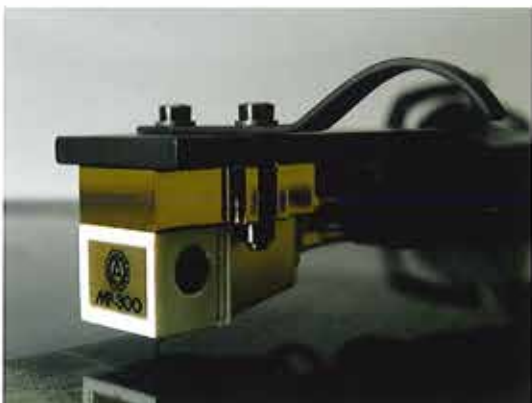

Output Voltage	3,0 mV (5 cm/sec)
Frequency characteristics	20-25.000 Hz
Channel Separation	25 dB (1 KHz)
Channel balance	1.0 dB or less
Load resistance	47 K Ω
Cantilever	Boron
Stylus tip shape/radius	0.4 x 0.7 mil elliptical
Stylus tip material	naked diamond
Stylus pressure	1,3 – 1,8 g
Cartridge weight	8,0 g

- [Tonar article no. 9351](#)
- [Tonar article no. 9399 \(premounted in headshell\)](#)

NAGAOKA MP-200

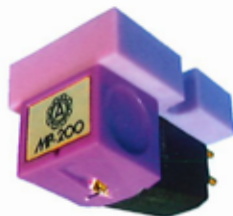

The Nagaoka MP-200 is a cartridge of musical contrasts. On the one hand, it offers an organic, fluid presentation with an engaging midrange reproduction of vocals and instruments. On the other hand, it retains the detail, lustre, dynamics and presence of music that are so often buried and attenuated by smooth sounding cartridges.

Output Voltage	4,0 mV (5 cm/sec)
Frequency characteristics	20-23.000 Hz
Channel Separation	25 dB (1 KHz)
Channel balance	1.5 dB or less
Load resistance	47 K Ω
Cantilever	Boron
Stylus tip shape/radius	0.4 x 0.7 mil elliptical
Stylus tip material	naked diamond
Stylus pressure	1,5 – 2,0 g
Cartridge weight	6,5 g

- Tonar article no. 9349
- Tonar article no. 9397 (premounted in headshell)

NAGAOKA MP-110

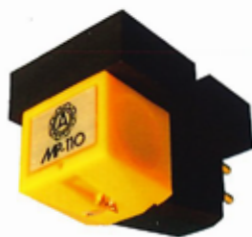

The Nagaoka MP-110 cartridge is world famous for its outstanding sound performance. Tracking and bass impact of this cartridge are exceptional, no matter if you are listening to classical music or rock, with everything in-between. The MP-110 has been selected by many leading high-end manufacturers for standard mounting in their turntables.

Output Voltage	5,0 mV (5 cm/sec)
Frequency characteristics	20-20.000 Hz
Channel Separation	23 dB (1 KHz)
Channel balance	1.5 dB or less
Load resistance	47 K Ω
Cantilever	aluminum alloy
Stylus tip shape/radius	0.4 x 0.7 mil elliptical
Stylus tip material	bonded diamond
Stylus pressure	1,5 – 2,0 g
Cartridge weight	6,5 g

- Tonar article no. 9345
- Tonar article no. 9393 (premounted in headshell)

NAGAOKA MP-150

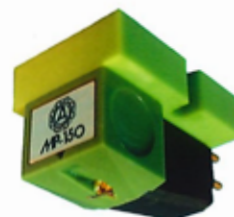

The Nagaoka MP-150 phono cartridge gives a fine solid bass, superb fluidity across the frequency spectrum, and sweet highs. To an artful listener who aspires for warm and accurate eloquence the Nagaoka MP-150 will be an endearing and lasting treasure.

Output Voltage	4,5 mV (5 cm/sec)
Frequency characteristics	20-20.000 Hz
Channel Separation	24 dB (1 KHz)
Channel balance	1.5 dB or less
Load resistance	47 K Ω
Cantilever	hardened tapered aluminum alloy
Stylus tip shape/radius	0.4 x 0.7 mil elliptical
Stylus tip material	naked diamond
Stylus pressure	1,5 – 2,0 g
Cartridge weight	6,5 g

- Tonar article no. 9347
- Tonar article no. 9395 (premounted in headshell)

NAGAOKA MP-100

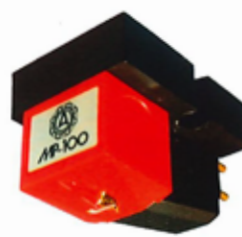

The entry level Nagaoka MP-100 phono cartridge offers musical clarity and expression beyond its price - a splendid upward start toward long term musical enjoyment with the fine quality of Nagaoka.

Output Voltage	5,0 mV (5 cm/sec)
Frequency characteristics	20-20.000 Hz
Channel Separation	22 dB (1 KHz)
Channel balance	2.0 dB or less
Load resistance	47 K Ω
Cantilever	aluminum alloy
Stylus tip shape/radius	0.6 mil spherical
Stylus tip material	bonded diamond
Stylus pressure	1,8 – 2,3 g
Cartridge weight	6,5 g

- Tonar article no. 9343
- Tonar article no. 9391 (premounted in headshell)

NAGAOKA 78 RPM styli series

assorted tip sizes for improved playback of Shellac records

The generally accepted tip radius for playback of 78 RPM records is 3.0 mil (0.003 inch). Due to the playback in the past of these very old records with very high stylus pressure and often with steel needles a lot of damage has been made to the grooves. This damage is the cause of a lot of distortion and background noise. Sometimes better results can be achieved by playing the record either on a lower part or a higher part of the groove which may have been damaged less than the damage found on the average playback height. To play-back at a higher level in the groove, use either the 3.5 mil or the 4.0 mil tip. To playback at a lower groove level use either the 2.0 mil, or 2.5 mil tip. When you have found the best height affix a sticker to the record so you will know the next time which stylus tip to use for best results.

MP - 1.0

■ Tonar article no. 6837



MP - 2.0

■ Tonar article no. 6839



MP - 2.5

■ Tonar article no. 6845



MP - 3.0

■ Tonar article no. 6835



MP - 3.5

■ Tonar article no. 6841



MP - 4.0

■ Tonar article no. 6843



NAGAOKA DJ-03HD

DJ cartridge for scratching

The Nagaoka DJ-03D is designed with precision for excellent skip resistance. This powerful cartridge ensures a continuous connection to the record during even the most energetic scratch performances. The fluorescent tip makes it easy for the DJ to put the stylus in the desired part of the groove. The cartridge is premounted in a SME connection type DJ headshell and fits directly onto the arm of the Technics SL-1200 DJ type turntables and its clones. The inside of the DJ-03D cartridge has been incorporated into a number of private label cartridges by well known DJ turntable manufacturers.

Output Voltage	6,0 mV (5 cm/sec)
Frequency characteristics	20-20.000 Hz
Channel Separation	20 dB (1 KHz)
Channel balance	1.5 dB
Load resistance	47 KΩ
Cantilever	aluminum alloy
Stylus tip shape/radius	0.6 mil conical
Stylus tip material	bonded diamond
Stylus pressure	3 – 5 g
Cartridge weight	5,2 g

■ Tonar article no. 9502 (premounted in SME connection type DJ headshell)



NAGAOKA Hi Clean AM-801

stylus cleaning fluid

Your phonograph stylus also needs cleaning and care. Due to air pollution caused by both outside influences (traffic exhaust fumes) and domestic influences (kitchen, fumes and smoking) a sticky film is deposited over time on to your records. During playback the stylus will scrape this deposit from the groove which in turn causes a sticky film to form around the stylus tip. This grime traps other dirt and dust found on your record. This easily visible thick deposit not only influences the quality of the sound, but if allowed to build up further, may even cause the stylus to jump out of the groove and to do damage to your favourite records. The special formula of the Nagaoka AM-801 efficiently dissolves all the sticky substance caught on the stylus and removes this as well as all the dirt trapped.

■ Tonar article no. 3281

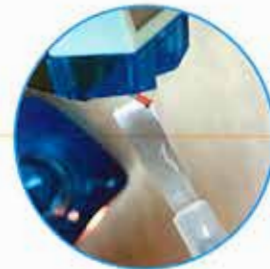

NAGAOKA Cartridge Mounting Screws

assorted packs of cartridge screws and nuts

BN-7b (black)

BN-7s (aluminum)



Screw Sizes and Quantity:

M2.6 x 3mm	- 4x
M2.6 x 6mm	- 2x
M2.6 x 8mm	- 2x
M2.6 x 10mm	- 2x
M2.6 x 12mm	- 2x
M2.6 x 14mm	- 2x
M2.6 x 18mm	- 4x
M2.6 Nut	- 4x
Nylon Washer	- 4x

■ Tonar article no. 3085

■ Tonar article no. 3084

NAGAOKA Rolling Cleaner CL-1000

silicone record cleaning roll

Conventional record cleaners attempt to wipe away the dust and dirt. The Nagaoka Rolling Cleaner uses a special grade of silicone rubber-elastomer which has the property that it's sticky. Just rolling over the record surface while applying a little pressure is enough to remove all dust and dirt in the grooves. The very soft silicone rubber will deform and take the shape of the record groove, being able to clean even the hard-to-reach bottom of the groove. The silicone rubber literally sticks to the dust and dirt like a limpet and any dust particles will be removed.

When the roll has become dusty, simply wash it under tap water using a little hand soap. The dust will easily be rinsed off. After drying the roll with lint free paper, it will become just as sticky as when it was new. There is no danger that you will damage the label when rolling over the complete record. Important! Always roll in straight lines over the grooves and the record label and do not attempt to follow the grooves in curves as this could do irreparable damage to the silicone rubber.

■ Tonar article no. 5929



NAGAOKA Recopack DC-203

record cleaning system



The Nagaoka Recopack is a cleaning system for very dirty records. A special syrup is distributed on the record using the supplied dispenser. A removal tag is placed on the edge of the record, halfway, in the still fluid syrup. Then the syrup is allowed to dry into a film during 24 hours. Once the film is dry you can remove it carefully by lifting the tab. All parts that do not belong to the record are now trapped in the film, even residue from previous use of for instance Lenco clean fluid.

■ Tonar article no. 3114

NAGAOKA Argento CL-118

velvet record cleaning brush

The Nagaoka Argento record brush uses the finest velvet available on the market and comes with a compact storage container and a built-in brush cleaner. The velvet reaches deep into the grooves and removes even the smallest dust particles.

■ Tonar article no. 5534



NAGAOKA RS-LP II (formerly Discfile No: 102)

the improved Nagaoka 25 micron anti-static record sleeves



Paper sleeves leave dust on the record and poly ethylene sleeves cling to the record. When removing the record from the sleeve, the polyethylene generates static charge which attracts the sleeve to the record and causes the dust caught between the sleeve and the record to scratch the record. The Nagaoka RS-LP II new improved version of the world famous Nagaoka Discfile no: 102 is anti-static and super slippery thus leaving the record completely unharmed.

■ Tonar article no. 3073

NAGAOKA 108/3

jacket cover for LP albums

Protect your valuable record albums covers from dust, grease and scratches with these Nagaoka outer sleeves. Nagaoka album covers for LP albums are supplied in packs of 10.

■ Tonar article no. 4643



NAGAOKA JC 30 LP

improved outer-sleeves for LP albums

With a thickness of 100μ, these improved Nagaoka strong outer-sleeves protect your important record album covers from scratches greasy fingers and dust.

Dimensions: 325 mm in width × 325 mm in height. Supplied in packs of 30.

■ Tonar article no. 5540



NAGAOKA Audio Isolators

combining Ruby with metal for better isolation

The Nagaoka Audio Isolators isolate your audio equipment from unwanted vibrations in the room, hence reducing the effect of acoustic feedback. As one of the cardinal gems, the Ruby is the only crystal material which is close to the hardness of the diamond. As such, the Ruby gem used in the Audio Isolators helps to suppress resonance and avoid vibrations. The Audio Isolators are available in two combinations: Ruby & Stainless Steel (INS-SU01) and Ruby & Brass (INS-BR02). When the product is installed, the Ruby gem remains visible, providing a luxurious feeling due to the contrast between the metallic lustre and the ruby gloss.

Isolator INS-SU01

■ Tonar article no. 4368



Isolator INS-BR02

■ Tonar article no. 4370

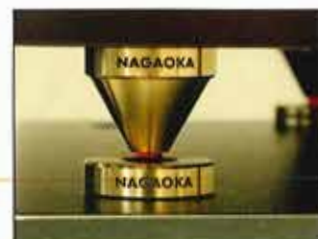

NAGAOKA Disc Stabilizer

record weight

The Nagaoka Disc Stabilizer, made from stainless steel, ensures a good contact between the record and the turntable platter. Pressing the record during playback will temporarily flatten warped records. In addition, the sound will improve, as unwanted resonances are suppressed and the grooves can be traced more accurately. Dimensions: 74 mm diameter x 22 mm. Caution: Please ensure that the platter bearing of your turntable is able to accept the additional weight of 600 grams. If in any doubt, please consult your record player instructions or your dealer.

■ Tonar article no. 5539



NAGAOKA 45 RPM Aluminum Adaptor

record adaptor

This record adaptor has been designed to be used with your 45 RPM records that no longer have the centres in them enabling you to play your old favourites.

■ Tonar article no. 3031



NAGAOKA In-Ear Headphones

world's first in-ear headphones using Ruby in the acoustic filter

Nagaoka is famous for its high precision processing and micro fabrication for difficult-to-cut materials. Now, Nagaoka has applied the red coloured Ruby in the acoustic filter of the in-ear headphones.

Ruby is a material of high hardness and is able to suppress internal resonance and compensate for the low frequencies. The special design makes the Ruby on the inside visible from the outside. In addition, these in-ear headphones are equipped with a one pole-type balanced armature for the speaker unit. This results in a multi dimensional sound, with excellent resolution, detail and sensitivity.

Specifications

Unit type:	balanced armature x 1
Sensitivity:	113 dB / 1 kHz / 1 mW
Frequency range:	4 - 90,000 Hz
Input power:	20 mW
Impedance:	31 Ω
Weight:	8 g
Input Connector:	L type Φ3.5 mm(1/8") Gold-plated
Cable:	1.2m Silver-plated 4N-OFC
Included accessories:	Silicon ear pieces(S,M,L) COMPLY™ form ear pieces(T-400 L) Real leather Carrying pouch Ear wax filter replacement parts Instruction Manual

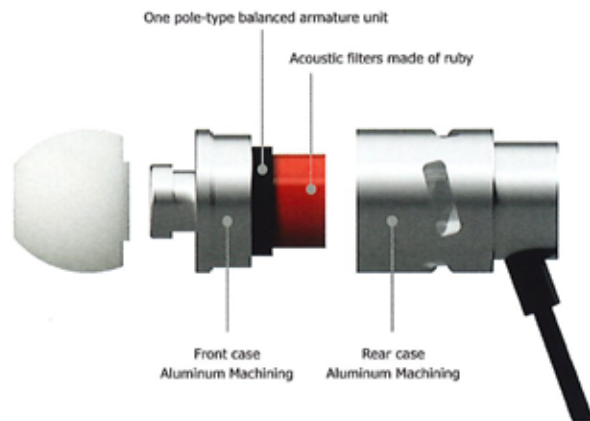

NAGAOKA x TENDO HPS-1K

original headphone stand made of Japanese Keyaki wood

In close cooperation with the renowned Japanese furniture maker Tendo Mokko, Nagaoka has designed a headphone stand made of molded Japanese keyaki wood (zelkova). This luxury stand is completely produced by hand and combines a touch of smoothness with refined elegance. Tendo has been one of the first companies in Japan to use formed plywood to mass-produce good-quality furniture. Tendo has collaborated with top architects and designers worldwide to create the most complicated curved lines with natural wood.

Size: 127 mm (w) x 157 mm (d) x 350 mm (h)
Weight: 520 g.



■ Tonar article no. 5543

JICO®

NIPPON PRECISION JEWEL INDUSTRY CO., LTD.



 Super Analog Stylus Series

SETO-HORI 瀬戸彫

Super Analog Stylus Series

The JICO Super Analog Stylus (SAS) is a state-of-the-art replacement stylus, using sophisticated precision technology to improve the analog sound experience for audiophiles. The SAS shape allows the stylus to reach the elusive parts of the grooves, while minimizing friction and record wear.

The SAS tip

The tip of the SAS is carefully chosen from single-crystal natural diamonds and is laser-cut with the most advanced electronic engineering technology. The SAS is designed to resemble the cutting stylus used to produce the master discs for vinyl record reproduction. This enables the SAS to have an optimal fit in the groove, which leads to less distortion at a high amplitude during playback.

The SAS offers the optimum tip design for accurate tracking of high-frequency passages. Variations in the size and shape of the stylus tip affect the amount of surface area which can be applied to the groove wall. By optimizing its curvature and reducing the minor radius, the SAS tip maximizes the contact surface area by a factor of 1.25 in comparison to other line contact styli. This allows the SAS to reproduce a more expansive bandwidth of information with higher fidelity. Hence, the SAS is able to retrieve details which were previously inaccessible to other styli.

The curvature of the tip shape is optimized to distribute effective mass, thereby eliminating excess pressure on the record groove wall and reducing distortion introduced by uneven wear. In addition, world-class polishing techniques are applied on each stylus, to further preserve the details of the record groove structure and to extend the life of the stylus with minimum abrasion.

■ The relation between stylus tip shape and contact surface

	Point contact stylus		Line contact stylus
	Conical Stylus 0.7 mil	Elliptical stylus 0.3x0.7 mil	S.A.S. stylus
Front view			
Gross-sectional view			
Contact with records			
Contact surface	23.4 μm ²	20.6 μm ²	62.1 μm ²
L ₁ / L ₂	1	1.8	9



The SAS cantilever

In order to transmit vibrations from the stylus tip to the transducer magnet faithfully, the cantilever of the SAS is supported by a specially constructed suspension. A single strand of ultra-fine piano wire is attached to the cantilever which then passes through the magnet before being secured internally to the housing. This helps to stabilize the movement of the magnet and reduce distortion from resonance that builds up as oscillations are transmitted through the cantilever, thus preserving the original signal down to the smallest detail.

To extract the maximum performance from the single point tension wire a specially shaped magnet is mounted coaxially to the cantilever. The magnet is composed of rare earth elements. The magnetic strength and reduced weight give it exceptional properties for transmitting the audio signals from the record groove.

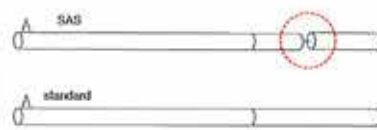

Tension wire controls the movement of the cantilever and the tip

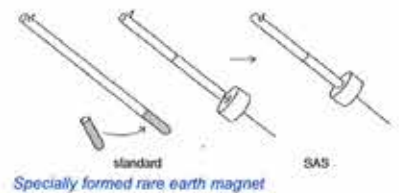

Specially formed rare earth magnet

Boron, Sapphire and Ruby

The cantilever of the SAS comes in three versions: boron (B-SAS), sapphire (S-SAS) and ruby (R-SAS).

Boron is one of the most suitable materials for cantilevers. Its density is low, it is very stiff and the speed of sound propagation is approximately 2.6 times faster than that of aluminium. Due to these characteristics, a boron cantilever can trace the information contained in the record grooves more precisely than aluminium cantilevers.

Sapphire has a high rigidity, which enhances the reproducibility of the sound engraved on analog records. Compared to aluminium cantilevers, every single sound will be defined more clearly, allowing the users to enjoy a crystal-clear sound.

Ruby enjoys all the benefits of the sapphire cantilever with one crucial advantage: the four facets of the crystalline ruby cantilever taper toward the diamond tip. This tapered ruby cantilever design allows for lower moving mass, giving even greater ability to reproduce vibrations in the record groove with precision, accuracy, speed and fidelity.



B-SAS boron cantilever



S-SAS sapphire cantilever



R-SAS ruby cantilever



JICO Super Analog Stylus Series

JICO®

NIPPON PRECISION JEWEL INDUSTRY CO., LTD.

Tonar no.:	Replacement stylus for:	Cantilever type:
6526 B-SAS	Elac D-793SH	Boron cantilever
6533 B-SAS	National/Technics EPS-30 ES	Boron cantilever
6537 B-SAS	National/Technics EPS-202 ED	Boron cantilever
6534 B-SAS	National/Technics EPS-205 CEX	Boron cantilever
6535 B-SAS	National/Technics EPS-205 ED	Boron cantilever
6531 B-SAS	National/Technics EPS-270 ED	Boron cantilever
6553 B-SAS	Philips GP-400 I	Boron cantilever
6554 B-SAS	Philips GP-400 II	Boron cantilever
6555 B-SAS	Philips GP-400 III	Boron cantilever
6528 B-SAS	Shure M-75 series	Boron cantilever
6530 B-SAS	Shure M-91 series	Boron cantilever
6540 B-SAS	Shure M-92 E	Boron cantilever
6532 B-SAS	Shure M-95 ED	Boron cantilever
6538 B-SAS	Shure M-97 XE	Boron cantilever
6539 B-SAS	Shure M-110E	Boron cantilever
6527 B-SAS	Shure V-15 II, VN-15 MR	Boron cantilever
6524 B-SAS	Shure V-15 III-MR, VN-35 MR	Boron cantilever
6525 B-SAS	Shure V-15 IV-MR, VN-45 MR	Boron cantilever
6529 B-SAS	Shure V-15 V-MR, VN-5 MR	Boron cantilever
6536 B-SAS	Shure V-15 V-x MR, VN-5 MR	Boron cantilever

6411 S-SAS	Elac D-793SH	Sapphire cantilever
6429 S-SAS	National/Technics EPS-30 ES	Sapphire cantilever
6438 S-SAS	National/Technics EPS-202 ED	Sapphire cantilever
6432 S-SAS	National/Technics EPS-205 CEX	Sapphire cantilever
6434 S-SAS	National/Technics EPS-205 CIIS	Sapphire cantilever
6427 S-SAS	National/Technics EPS-270 ED	Sapphire cantilever
6424 S-SAS	Shure M-75 series	Sapphire cantilever
6426 S-SAS	Shure M-91 series	Sapphire cantilever
6477 S-SAS	Shure M-92 E	Sapphire cantilever
6428 S-SAS	Shure M-95 ED	Sapphire cantilever
6441 S-SAS	Shure M-97 XE	Sapphire cantilever
6454 S-SAS	Shure M-110E	Sapphire cantilever
6416 S-SAS	Shure V-15 II, VN-15 MR	Sapphire cantilever
6407 S-SAS	Shure V-15 III-MR, VN-35 MR	Sapphire cantilever
6409 S-SAS	Shure V-15 IV-MR, VN-45 MR	Sapphire cantilever
6425 S-SAS	Shure V-15 V-MR, VN-5 MR	Sapphire cantilever
6435 S-SAS	Shure V-15 V-x MR, VN-5 MR	Sapphire cantilever

6520 R-SAS	National EPS-205EX	Ruby cantilever
6522 R-SAS	Shure M-97 XE	Ruby cantilever
6517 R-SAS	Shure V-15 III-MR, VN-35 MR	Ruby cantilever
6518 R-SAS	Shure V-15 IV-MR, VN-45 MR	Ruby cantilever
6519 R-SAS	Shure V-15 V-MR, VN-5 MR	Ruby cantilever
6521 R-SAS	Shure V-15 V-x MR, VN-5 MR	Ruby cantilever

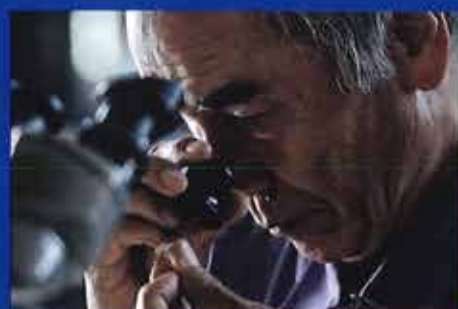

SETO-HORI

瀬戸彫

A Hand-Crafted MC Cartridge with a Ceramic Body featuring a Micro Ridge Diamond Tip and a Boron Cantilever

JICO now launches the "SETO-HORI" Moving Coil (MC) type cartridge. The SETO-HORI MC cartridge is made in the heart of the city of Seto, Japan. This city is famous for its pottery and ceramics. So much, that the generic word for ceramics in Japanese is "Setomono".

For two years, the stylus experts of JICO cooperated with a laboratory in Seto to create the ceramic cabinet. The *Setomono* ceramic cabinet suppresses excess vibration of the high output voltage MC cartridge. The SETO-HORI cartridge uses a special "micro ridge diamond tip", which has a polyhedral shape. Being a line-contact stylus, its life time is at least three times longer compared to ordinary conical or elliptical shaped styli. The cantilever is made of Boron which has a low mass and great stiffness. These characteristics allow the tip to trace the groove more accurately and reproduce low, mid-range and high-frequencies with true fidelity.

The unique pattern of the SETO-HORI cartridge resembles fishing nets of the fishermen in Japan. It follows the philosophy of capturing happiness by capturing beautiful sounds. The detailed pattern imitating the fishing nets is not painted with a brush, but drawn by the mould with a technique called "Hori-Tsuke".

The cartridge body is mounted on a base made of natural walnut tree wood and is processed near Hamamatsu, the city famous for its world-class musical instrument factories. Combining traditional Japanese ceramic and natural wood gives an additional charm to the sound. The SETO-HORI MC cartridge is purely hand-made in Japan.



Specifications:
 Output voltage: 2mV
 Output balance: <1.5dB/1kHz
 Stylus force: 2.0 g
 Channel separation: 25dB/1kHz
 Frequency response: 15-32,000Hz
 Output impedance: 130Ω/1kHz
 Cantilever: Boron
 Stylus shape: Micro Ridge
 Product net weight: 11 g
 Shielding case: Ceramic ware from Seto and walnut tree wood.

All cartridges are shipped with 100% shipping inspection and sound check.

Tonar no. 9636 - SETO HORI MC Cartridge

JICO®

NIPPON PRECISION JEWEL INDUSTRY CO., LTD.

The journey of JICO began in 1873, when its original founder Ichihara Soubei learned manufacturing techniques from Europeans in Nagasaki (Japan). He used these skills to start his own small factory for crafting sewing needles for Kimonos in the remote village of Hamasaka, three hours away from Osaka in the Japanese countryside. The craftsmanship of the sewing needles was so well received, that soon they became known as *Misuya* needles, named for the Kimono they used to make. Due to the remote location of the factories in Hamasaka, the company developed a strong self-reliance on all aspects of the production process and this has contributed to its technological strenght.

As time moved on, the focus of JICO continued with the manufacturing of phonograph needles. In 1959, JICO started with the production of steel needles for phonographs. However, in 1964, JICO's technical expertise and meticulous craftsmanship was blended with the manufacturing of diamond-tipped styli.

At the heart of JICO's high standard are the skilled *Takumi* (Japanese artisans) who hand assemble and check all JICO styli. Stringent quality inspections and tests using unique and high level technology are performed on all materials and at every level — from the manufacture of parts that transmit vibrations to the cartridge (the cantilever, magnet and wire) to the final assembly. Combining unique precision technology with great dedication, has turned JICO styli to become today's quality benchmark. Building on a long history and an ear for quality, JICO is committed to preserving the vinyl record culture and sound for many generations to come.

JICO is exclusively represented by Tonar International for distribution in Europe, Africa and the Middle-East. Both companies share a long history of fruitful cooperation. Established in 1954, Tonar has become the specialist for analog audio, phonograph styli, cartridges and accessories for your turntable and vinyl collection.



tonar
www.tonar.eu

Your JICO dealer:

BEKAFUN

Heilig hartstraat 23
8870 Izegem (BE)
info@bekafun.be
www.bekafun.be

made with
high precision in Tokyo

ONEARM ACCESSORIES

JAC 501/502

tonearm connector cables



Five-pin plug with
straight DIN connector.

● Tonar article no. 4492

Five-pin plug with
90 degrees DIN connector.

● Tonar article no. 4493

Specifications:

Conductor: OFC
Outer jacket: Flexible PVC
DIN Connector: Phosphor bronze, Brass and others
RCA Connector: Phosphor bronze, Brass and others

JAC 506

XLR balanced tonearm connector cables



Straight 5 pin DIN to 2 XLR
plugs – sep earth.

● Tonar article no. 5385

90 degrees 5 pin DIN to 2
XLR plugs – sep earth.

● Tonar article no. 5908

Specifications:

Conductor: OFC
Outer jacket: Flexible PVC
DIN Connector: Phosphor bronze, Brass and others
XLR Connector: Copper (PCOCC), Aluminum and others

JAC 101/102

economy tonearm connector cables (gold plated)

Five-pin plug with
straight DIN connector.

● Tonar article no. 5454

Five-pin plug with
90 degrees DIN connector.

● Tonar article no. 5456



JL-45

hydraulic tonearm lifter

● Tonar article no. 4498



DO-01

spare oil for oil damped
tonearms

● Tonar article no. 5981



JELCO

ONEARMS AND ACCESSORIES FOR TURNTABLES



made with high precision in Tokyo

TK-950

TK-950L

12" Dynamic-balance / Static-balance compatible with Knife Edge S-type tonearm

- Tonar article no. 5531



TK-950S

9" Dynamic-balance / Static-balance compatible with Knife Edge S-type tonearm

- Tonar article no. 5530



Features:

- The TK-950 tonearms have a unique two-way balance system, allowing for Dynamic-balance or Static-balance.
- The bearing for vertical direction is equipped with an innovative KNIFE EDGE system.
- The Knife Edge material is made from super steel, and has a very stable and smooth operation.
- The Knife Edge system is hand-made, using precision technology for very low friction.
- The high-mass design and the selected materials suppress unwanted vibrations and enhance the sound quality.
- The tonearm's geometry allows for a Baerwald protractor alignment.
- The universal type counterweight can be used for cartridge/headshell combinations with a weight from 17 to 35 grs.
- The tonearms are fitted with a detachable headshell.
- The included magnesium alloy headshell features cartridge azimuth adjustment.
- Digital stylus pressure gauge (SG-1) included.

Model	TK-950L	TK-950S
Bearing System	Knife Edge	
Effective length (from the tonearm pivot to stylus point)	303 mm	232 mm
Distance of the tonearm pivot to spindle	290 mm	214 mm
Overhang (spindle to stylus point)	13 mm	18 mm
Offset angle	17.7°	23.75°
Tracking error angle	+1.45°-0.85°	+1.96°-1.03°
Horizontal sensitivity (first action, inner wire free)	30 mg	30 mg
Vertical sensitivity (first action, inner wire free)	30 mg	30 mg
Suitable cartridge weight with headshell	17-35 gr	17-35 gr
Effective Mass	13.0 gr	13.4 gr
Range of height adjustment (distance between the arm base bottom and centre of the arm pipe)	38-60 mm	38-60 mm

TK-850

TK-850L

12" Static-balance with Knife Edge S-type tonearm

- Tonar article no. 5529



TK-850S

9" Static-balance with Knife Edge S-type tonearm

- Tonar article no. 5528



Features:

- The TK-850 tonearms use a Static-balance system.
- The bearing for vertical direction is equipped with an innovative KNIFE EDGE system.
- The Knife Edge material is made from super steel, and has a very stable and smooth operation.
- The Knife Edge system is hand-made, using precision technology for very low friction.
- The high-mass design and the selected materials suppress unwanted vibrations and enhance the sound quality.
- The tonearm's geometry allows for a Baerwald protractor alignment.
- The universal type counterweight can be used for cartridge/headshell combinations with a weight from 17 to 35 grs.
- The tonearms are fitted with a detachable headshell.
- The included magnesium alloy headshell features cartridge azimuth adjustment.

Model	TK-850L	TK-850S
Bearing System	Knife Edge	
Effective length (from the tonearm pivot to stylus point)	303 mm	232 mm
Distance of the tonearm pivot to spindle	290 mm	214 mm
Overhang (spindle to stylus point)	13 mm	18 mm
Offset angle	17.7°	23.75°
Tracking error angle	+1.45°-0.85°	+1.96°-1.03°
Horizontal sensitivity (first action, inner wire free)	30 mg	30 mg
Vertical sensitivity (first action, inner wire free)	30 mg	30 mg
Suitable cartridge weight with headshell	17-35 gr	17-35 gr
Effective Mass	13.0 gr	13.4 gr
Range of height adjustment (distance between the arm base bottom and centre of the arm pipe)	38-60 mm	38-60 mm

TS-550

TS-550L

12" Static-balance oil damping S-type tonearm

- Tonar article no. 5532



TS-550S

9" Static-balance oil damping S-type tonearm

- Tonar article no. 5535



Features:

- The TS-550 tonearms incorporate an oil damping system. This improves bass performance, and protects vinyl records from damage caused by jumping of the stylus during playback.
- The bearing for vertical direction is equipped with a one point cross suspension system with low friction.
- The mechanism enhances the sound quality.
- The tonearm's geometry allows for a Baerwald protractor alignment.
- The universal type counterweight can be used for cartridge/headshell combinations with a weight from 17 to 34 grs.
- The tonearms are fitted with a standard detachable headshell.

Model	TS-550L	TS-550S
Bearing System	One point cross suspension	
Effective length (from the tonearm pivot to stylus point)	303 mm	232 mm
Distance of the tonearm pivot to spindle	290 mm	214 mm
Overhang (spindle to stylus point)	13 mm	18 mm
Offset angle	17.7°	23.75°
Tracking error angle	+1.45° - 0.85°	+1.96° - 1.03°
Horizontal sensitivity (first action, inner wire free)	30 mg	30 mg
Vertical sensitivity (first action, inner wire free)	30 mg	30 mg
Suitable cartridge weight with headshell	17-34 gr	17-34 gr
Effective Mass	9.0 gr	9.2 gr
Range of height adjustment (distance between the arm base bottom and centre of the arm pipe)	38-60 mm	38-60 mm
Additional function	Oil damping	

TS-350

TS-350L

12" Static-balance S-type tonearm

- Tonar article no. 5536



TS-350S

9" Static-balance S-type tonearm

- Tonar article no. 5537



Features:

- The TS-350 tonearms use Jelco's stable basic mechanism.
- The bearing for vertical direction is equipped with a one point cross suspension system with low friction.
- The mechanism enhances the sound quality.
- The tonearm's geometry allows for a Baerwald protractor alignment.
- The universal type counterweight can be used for cartridge/headshell with a weight from 17 to 34 grs.
- The tonearms are fitted with a standard detachable headshell.

Model	TS-350L	TS-350S
Bearing System	One point cross suspension	
Effective length (from the tonearm pivot to stylus point)	303 mm	232 mm
Distance of the tonearm pivot to spindle	290 mm	214 mm
Overhang (spindle to stylus point)	13 mm	18 mm
Offset angle	17.7°	23.75°
Tracking error angle	+1.45° - 0.85°	+1.96° - 1.03°
Horizontal sensitivity (first action, inner wire free)	30 mg	30 mg
Vertical sensitivity (first action, inner wire free)	30 mg	30 mg
Suitable cartridge weight with headshell	17-34 gr	17-34 gr
Effective Mass	9.0 gr	9.2 gr
Range of height adjustment (distance between the arm base bottom and centre of the arm pipe)	38-60 mm	38-60 mm

JELCO

Jelco (Ichikawa Jewel Co., LTD) was started in 1920 by Y. Ichikawa. Originally set up to manufacture jewel bearings for watches and measuring equipment, in 1958 the company branched out to creating diamond tipped styli for use in the Hi-Fi industry.

Jelco is now one of the few remaining tonearm manufacturers left in Japan and continues to utilise its 'Zero Friction Technology' for stunning musical reproduction.



Your Jelco dealer:

BEKAFUN

Heilig hartstraat 23
8870 Izegem (BE)
info@bekafun.be
www.bekafun.be

JELCO

HEADSHELLS

TopQ High End Headshells

Most turntables are supplied with a standard entry level headshell. The sound quality can be strongly improved by using a so-called "high end shell". The TopQ High End headshells come in two versions, one with a removable arm lifter and one with a fixed arm lifter. Both models have the possibility to adjust the pitch of the shell axial wise, as compared to the tonearm. This allows an exact vertical mounting of the cartridge and stylus tip onto the record. The finest quality OFC (Oxygen Free Copper) lead wires are used in the TopQ headshells. Both models are available in black or in silver/bronze. All TopQ models have a SME type connector for use on S-type tonearms.



TopQ headshell (black)
with removable arm lifter
• Tonar article no. 4420



TopQ headshell (black)
with fixed arm lifter
• Tonar article no. 5330



TopQ headshell (silver/bronze)
with removable arm lifter
• Tonar article no. 5907



TopQ headshell (silver/bronze)
with fixed arm lifter
• Tonar article no. 5386

Specifications:

- Magnesium Alloy body
- Azimuth adjustable
- Universal mount
- Two lock pin
- Silk weaved OFC litz lead wires with gold plated terminal
- PIN conductor: Gold plated
- Weight: 12.1 grams without screws

Rosewood High End Headshell

This state-of-the-art headshell made of Rosewood, is a high quality audiophile headshell and provides an elegant solution with a variety of cartridges. It has a SME style locking collar (as found on most tone arms with removable headshells). The connectors are gold plated and the included headshell leads are silver plated.

• Tonar article no. 5327



Specifications:

- Magnesium Alloy body with rosewood
- Azimuth adjustable
- Universal mount
- Gold plated copper arm lifter
- Two lock pin
- 4N all pure silver lead wires with gold plated terminal
- PIN conductor: Gold plated
- Weight: 16.9 grams without screws



BEKAFUN

Heilig Hartstraat 23 B-8870 Izegem | info@bekafun.be | 051 31 28 03
Open: ma-vr 9u-18u | za 10u-17u